

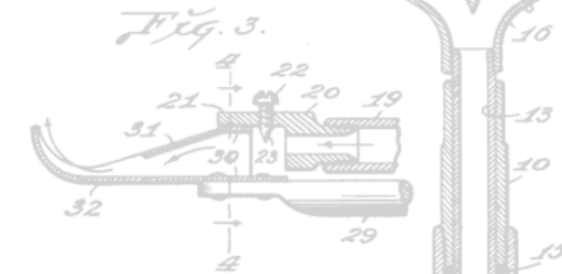

LXME2 & LXME2 PRO

Next generation in modular traditionally wired controllers

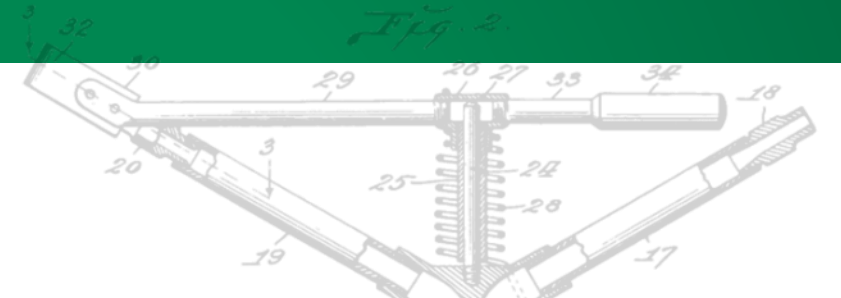
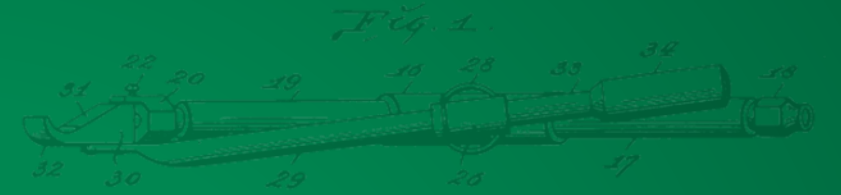

INVENTOR,
ORTON H. ENGLEHART
BY *Martin J. Smith* ATTY.

LXME2 & LXME2 PRO

Modular Design | Intuitive Operation | Powerful Water Management

- 40 programs; 10 start times each
- Large backlit display with easy-to-navigate soft key user interface
- Copy/ paste program information from one station to many
- Easy upgrade from LXME to LXME2 by swapping the front panel
- 12-station base unit expandable to 48 stations
- Optional upgrade to LXME2 **PRO** with Pro Smart Module
 - 1 Flow sensor input
 - 2nd booster pump circuit or NCMV programmable by station



LXME2 & LXME2 PRO

LXME2

- 40 programs; 10 start times each
- 12 – 48 Stations
- 1 Weather Sensor
- 1 MV Output
- 5 SimulStations (including MV)
- 3 Year Warranty

LXME2 PRO

- 1 Flow Sensor
- 2nd Pump Start Circuit (MV2/P)

LXME2



LXME2 PRO



More Programs!



LXME2 & LXME2 PRO

40 Programs



LXME

4 Programs

Giant Backlit Display!

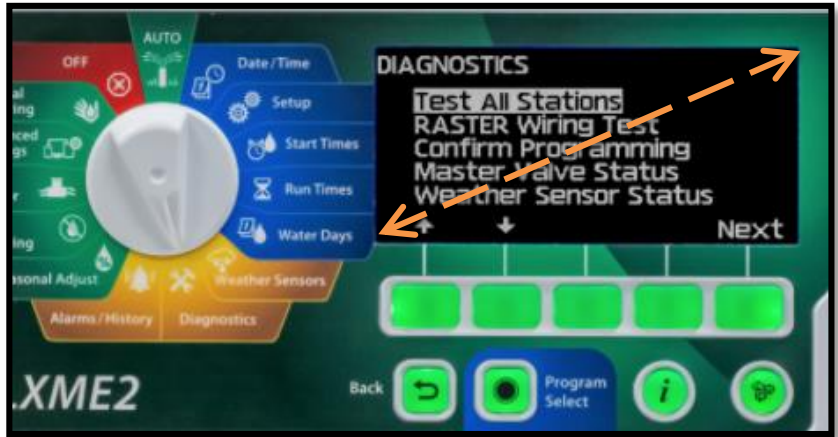

LXME2

5.5"

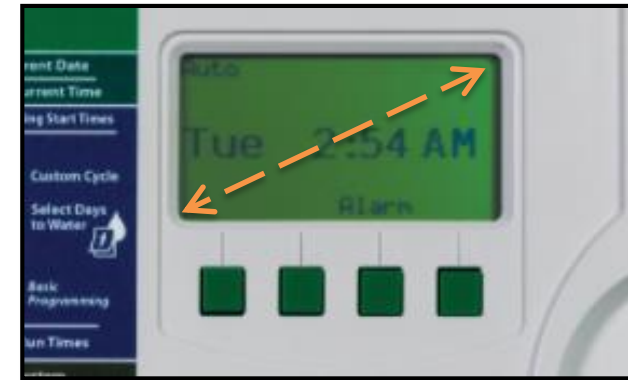

LXME

3 3/4"

Modular and easy to use with lots of connection options!

Multiple Central Control Connection Options

Primary Communication:

- Cellular
- Ethernet
- Fiber-Optics



Secondary Communication:

- Radio
- Hardwire/Connection Module

External Alarm Port



2nd Pump Start Circuit Programmable by Station **PRO**

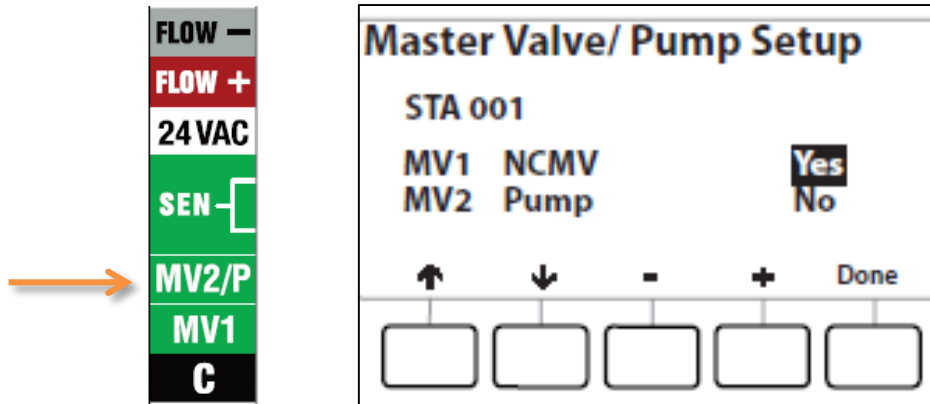

Copy/ Paste Programming

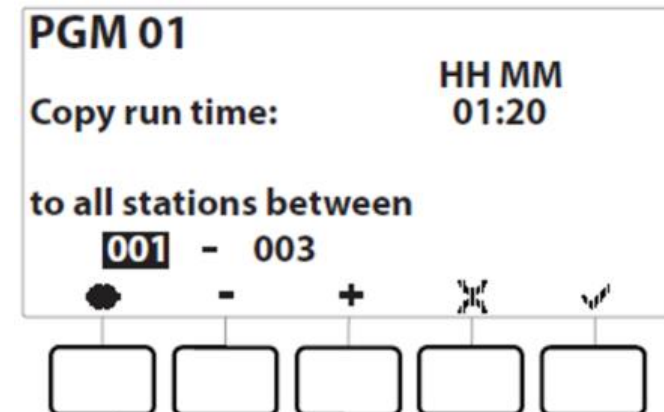

IQ4 Central Control



- LXME2 is only compatible with IQ4 and will have full functionality at launch
- ****The LXME2 is not compatible with IQ3 or prior versions of Rain Bird Central Control****

Retrofit Guide

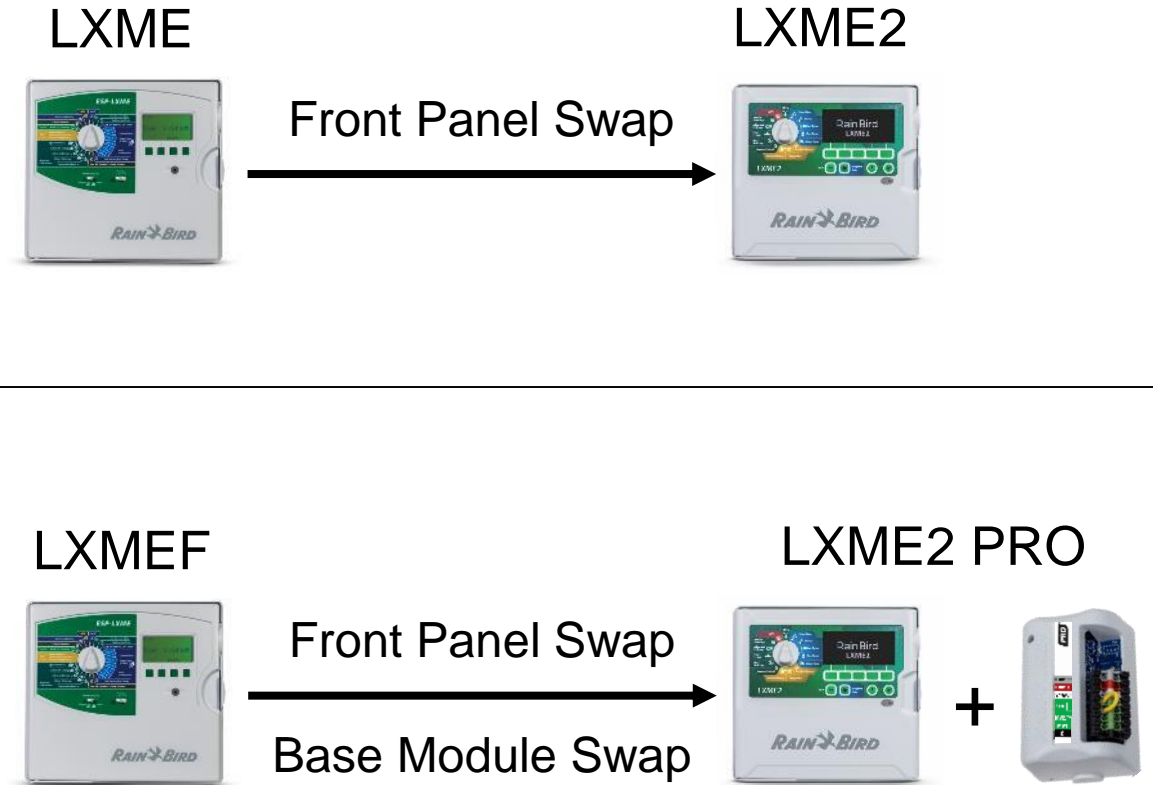

Notes

- Use 12 STA Modules Only
- 6 pin remotes will *not* work
- 5 pin remote options are available. See sales team for more info

LXME2 – Key Selling Features

LXME2

- 40 programs; 10 start times each
- New user interface is a lot easier to use
 - Industries largest screen with backlit buttons
 - Familiar programming for current LXME & LXIVM users
 - Copy and Paste makes programming a breeze

LXME2 PRO

- Buy PRO controller, or add a Pro Smart Module:
 - 1 Flow Sensor
 - 2nd Pump Start Circuit (MV2/P) programmable by station

FAQ

- ❑ Do the LXME2 and LXME2 PRO have different front panels?
- ❑ No.
- ❑ Can the 2nd pump start circuit (MV2/P) be used as a normally open MV?
- ❑ No. MV2/P can only be a NCMV
- ❑ Do the LXME2 and LXME2 PRO both have 40 programs?
- ❑ Yes.
- ❑ Can I use both 12 station screw and push-in terminals with the LXME2?
- ❑ Yes. The LXME2 is compatible with all 12 station modules
- ❑ Can I use 8 or 4 station modules with the LXME2?
- ❑ No. The user will see an alarm stating the 4 or 8 station modules are not compatible and to replace with 12 STA