

## TBOS-BT

### Bluetooth Battery-Operated Controller

Install anywhere. Program from a Smartphone.

#### Easy to Install

- Ideal for commercial applications, including municipal parks, street and highway landscape projects, and construction projects.
- Convenient durable option for providing uninterrupted irrigation while AC-power is not available.
- The TBOS potted latching solenoid will mount on all Rain Bird valves: DV, DVF, ASVF, PGA, PEB, PESB, GB, EFB-CP, BPE and BPES series.
- One Smartphone programs an unlimited number of TBOS-BT Control Modules.
- The TBOS solenoid adapters will adapt the potted latching solenoid for use in retrofit applications with selected Irritrol® (Hardie/Richdel) and Buckner® valves or Champion® and Superior® valve actuators.

#### Easy to Program

- Intuitive programing from the Rain Bird Smartphone app.
- User interface in 8 languages: English, French, Spanish, Portuguese, German, Italian, Turkish, Russian and Polish.
- Complete Manual irrigation mode.
- Built-in ID with naming capability (Control module the station names can be Backwardly compatible with TBOS-II Field Transmitter

#### Rain Bird App Features (TBOS-BT)

- The low battery indicator warns of failing batteries in the TBOS-BT control module.
- 3 local irrigation programs may be saved and restored from Field Transmitter.
- Capability to clear the Control module's irrigation program (individual or all).
- Capability to review the irrigation program.

#### Controller Features

- The following features are included on TBOS-BT Control module.
- Basic programming includes 3

- independent programs A,B and C, each with 8 start times per day.
- Stations can be assigned to several programs with different watering run times.
- Run time is from 1 minute to 12 hours in 1-minute increments.
- Independent station operation allows sequential start times (with stacking in case of overlap).
- Program and global Monthly Seasonal Adjust; 0% to 300% (1% increment).
- Five watering day cycle modes (Custom, even, odd, odd-31, cyclical) selectable by program for maximum flexibility and watering restriction compliance.
- Rain Delay from 1 to 14 days.
- Master valve output (on TBOS-BT 2, 4, and 6 Control Modules)
- A TBOS Backup program may be saved and restored.
- No loss of irrigation program after a battery replacement.

#### TBOS-BT System Components

##### Rain Bird App (TBOS-BT)

- Available for Android and IOS devices.

##### TBOS-BT Control Modules

- Available in 4 models: 1, 2, 4, or 6 stations.
- Operates one valve per station.
- Direct Rain Sensor Connection accommodates the Rain Bird RSD-BEx Rain Sensor.
- Operates with one 9V alkaline battery (Energizer and Duracell are recommended) type 6AM6 (international standard) or 6LR61 (European standard): battery not included.
- Battery life is one year with a high-quality 9V alkaline battery.
- Resists humid and harsh environments
- Rated IP68: 100% waterproof and fully submersible.
- Master Valve/Pump output on 2-, 4- and 6-station Control modules.
- Dimensions: 9.5 x 13.0 x 5.3 cm
- Weight: 500 g (17.64 ounces)



- Maximum wire run between the module and solenoid: 30m by using 1.5mm<sup>2</sup> (16 AWG) extended wire.

#### Certifications

- cULus, FCC Part 15b, ISED RSS-247 Issue 2.0, CE, IP68, ICASA, CITC, ACMA, SUBTEL, SRRC, MIC, IFETEL, CRA, TRA

#### TBOS System Accessories

- **TBOS Potted Latching Solenoid**
  - Two 0.75 mm<sup>2</sup> wires (18 gauge) are supplied: 60 cm long (23.6 inches)
  - Plastic adapter included for Rain Bird valves: DV, DVF, ASVF, PGA, PEB, PESB, GB, EFB-CP, BPE and BPES series.
  - 10 bars (150 psi) maximum operating pressure.
- **TBOS Solenoid Adapters**
  - Easy to install.
  - Black adapter for plastic valves allows the TBOS potted latching solenoid to be used with selected Irritrol (Hardie/Richel) and Buckner valves.
  - Brown adapter for brass valves allows the TBOS potted latching solenoid to be used with selected Champion and Superior valve actuators.
- **RSD-BEx Rain Shutoff Device**
  - Operates with 24V or 9V controllers, including TBOS, TBOS-II and TBOS-BT.
  - Designed to save water by automatically

measuring precipitation and keeping irrigation systems from watering in rainy conditions.

- Does not interrupt irrigation taking place, but subsequent program starts will be prevented.
- Automatic return to normal watering schedule when the moisture level decreases as a result of natural evaporation.

## How To Specify

- TBOS-BT Control Modules:
- TBOS-BT1 (1 station)
- TBOS-BT2 (2 stations)
- TBOS-BT4 (4 stations)
- TBOS-BT6 (6 stations)

## Specifications

### TBOS-BT Control Module

The irrigation controller (control module) shall be programmable from the Rain Bird Smartphone App, or using the TBOS-II Field Transmitter.

The programs and manual operations shall be communicated to the Control Module from a Smartphone via Bluetooth or from the TBOS-II Field Transmitter via an infrared connection.

The Control Module shall be of a module type which may be installed in a valve box underground.

The Control Module shall be housed in an ABS plastic cabinet and shall be potted to insure waterproof operation. Their battery compartment shall be dual-sealed to prevent water from entering the compartment. The Control Module shall have two mounting slots for screws allowing the module to be securely mounted inside a valve box. The controller shall be designed to accommodate one 9V alkaline battery (EN22- 6L561-6AM6-9V) for one full year regardless of the number of stations utilized.

The Control Module shall operate \_\_\_\_ (1, 2, 4 or 6) stations.

One sensor input shall be present on Control Module and shall accommodate dry contact

rain sensor.

\_\_\_\_ -station (2-, 4-, or 6-) modules shall be able to support a Master valve.

All valves shall affect the Master Valve / Pump.

The controller shall have station run time capability from one minute to twelve hours in one minute increments, a 365-day calendar with leap year and three programs A, B,C with eight start times each. One valve can be assigned to none, one, any or all programs.

Each program shall be capable of being set to any of the following: Custom Cycle (days of the week), Cyclic (1 to x days variable), Odd, Odd (no) 31 and Even.

The controller shall have a program level and global Monthly Seasonal Adjust; 0% to 300% (1% increment) A Rain Delay shall allow the user to suspend irrigation programs from 1 to 14 days.

The controller shall be capable of starting/ stopping a manual single valve or manual program, cancel irrigation in progress or launch a test valve via Bluetooth from the Rain Bird App or infrared of the Field transmitter.

Each valve not activated during the last 24 hours shall be automatically activated during 1 second each day for an anti-calcium effect.

TBOS Potted Latching Solenoid Control Module station output shall drive

one single potted latching solenoid that shall fit onto any Rain Bird Valves: DV, DVF, ASVF, PGA, PEB, PESB, GB, EFB-CP, or BPE or BPES series valve.

The Control Module, the Potted Latching

Solenoid, and the field transmitter shall be as manufactured by Rain Bird Corporation, Glendora, California USA.

### TBOS Rain Shutoff Device

The Rain Shutoff Device shall function correctly only when buried under 2" (5 cm) of sand. The device shall be pre-set and nonadjustable.

The device shall function with a DC system only. The device shall have a bypass switch. The Rain Shutoff Device shall be as manufactured by Rain Bird Corporation, Glendora, California USA.

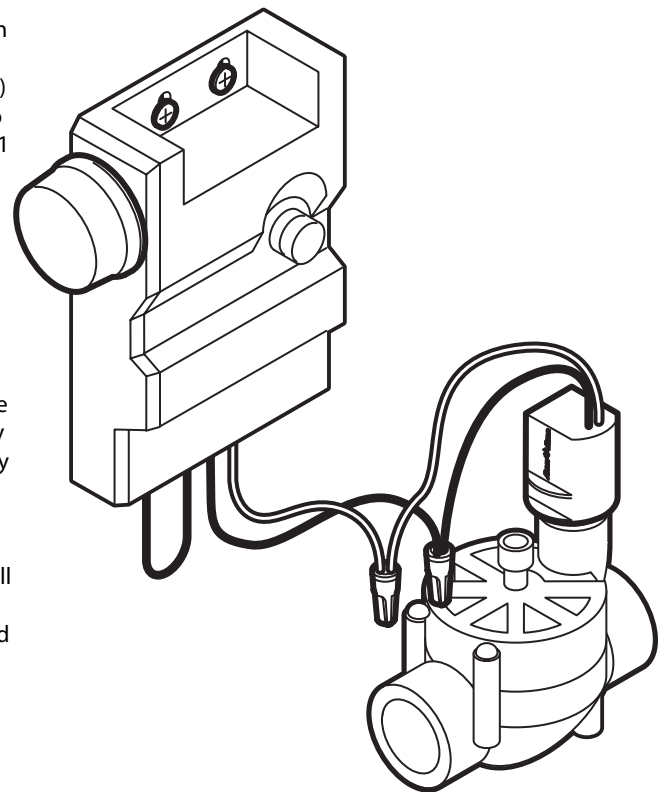

Rain Bird Corporation  
6991 East Southpoint Road  
Tucson, AZ 85756  
Phone: (520) 741-6100  
Fax: (520) 741-6522

Rain Bird Technical Services  
(800) RAINBIRD (1-800-724-6247) (U.S. & Canada)

Rain Bird Corporation  
970 West Sierra Madre Avenue  
Azusa, CA 91702  
Phone: (626) 812-3400  
Fax: (626) 812-3411

Rain Bird International, Inc.  
1000 West Sierra Madre Ave  
Azusa, CA 91702  
Phone: (626) 963-9311  
Fax: (626) 852-7343

The Intelligent Use of Water™  
www.rainbird.com