

FREE SPACE REQUIRED FOR MAINTENANCE

FREE SPACE REQUIRED FOR INSTALLATION

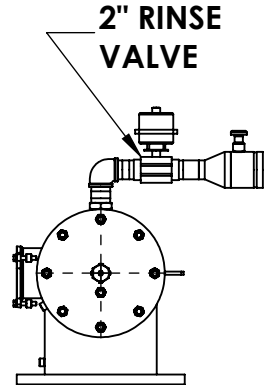
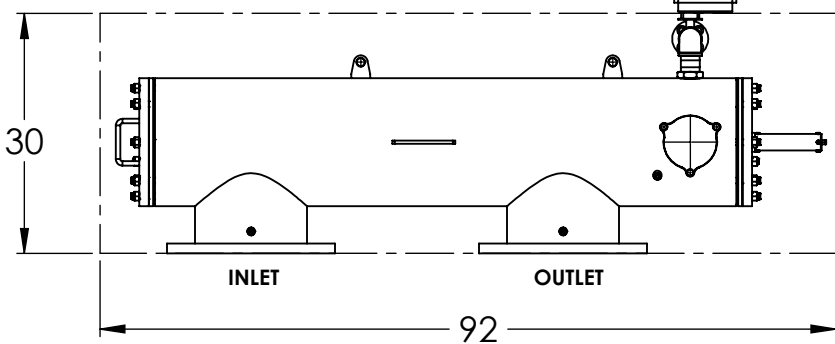
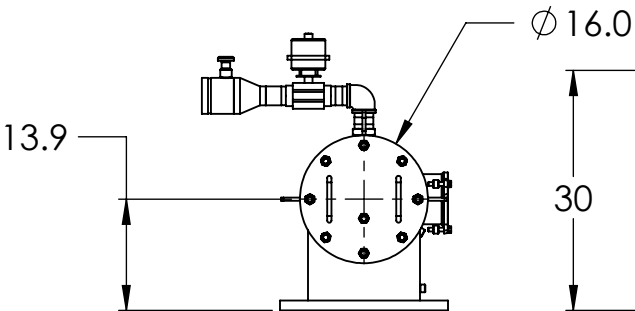

TECHNICAL DATA

MAXIMUM FLOW RATE:	3750 G.P.M
AVAILABLE SCREEN SIZES:	10, 25, 50, 80, 100, 150, 200, 300, 400, 800, 1000, 1500 MICRON
OPEN SCREEN AREA STANDARD SCREEN:	826 SQ. INCHES
OPEN SCREEN AREA HIGH PERFORMANCE MULTI-LAYERED SINTERED SCREEN:	1240 SQ. INCHES
MAXIMUM WORKING PRESSURE:	150 PSIG
MINIMUM INLET PRESSURE REQUIRED DURING RINSE CYCLE	30 PSIG
MAX. WORKING TEMPERATURE:	150°F
INLET/OUTLET FLANGES:	14" ASME B16.5 150# RF
DRAIN VALVE CONNECTION:	4" GROOVED
DRAIN HEADER SIZE:	4" MINIMUM
APPROXIMATE WEIGHT - DRY:	785 LBS.
APPROXIMATE SHIPPING WEIGHT:	955 LBS.
APPROXIMATE WEIGHT FULL OF WATER:	1270 LBS.

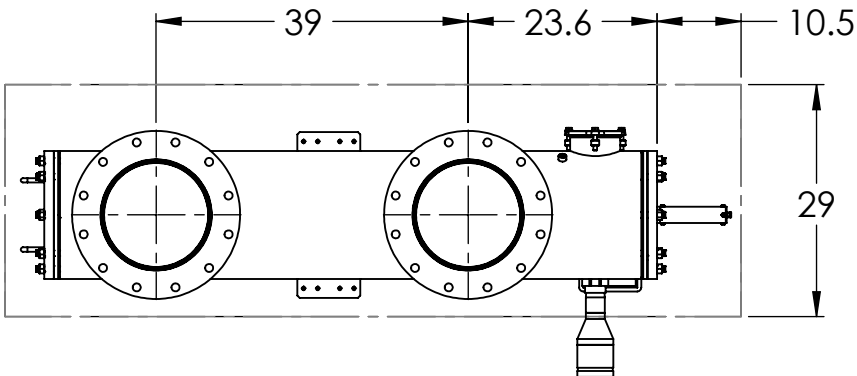

RAIN BIRD RESERVES THE RIGHT TO MODIFY FILTER DIMENSIONS WITHOUT PRIOR NOTICE

A PART NO. EXPLANATION PART NUMBER XXXXXX-XX BASE DWG NO. MFG OPTION (SEE TABLE OF NOTE) EXAMPLE: 652100-01	NOTICE: THIS DRAWING EMBODIES A CONFIDENTIAL PROPRIETARY DESIGN ORIGINATED BY RAIN BIRD CORPORATION. ALL DESIGN, MANUFACTURING, USE AND SALE RIGHTS REGARDING THE SAME ARE EXPRESSLY RESERVED. IT IS SUBMITTED UNDER A CONFIDENTIAL RELATIONSHIP FOR A SPECIFIC PURPOSE AND THE RECIPIENT AGREES BY ACCEPTING THIS DRAWING NOT TO SUPPLY OR DISCLOSE ANY INFORMATION REGARDING IT TO ANY UNAUTHORIZED PERSON, OR TO INCORPORATE IN OTHER PROJECTS ANY SPECIAL FEATURE UNIQUE TO THIS DESIGN. ALL COPYRIGHT AND PATENT RIGHTS HERETO ARE EXPRESSLY RESERVED.	1 INCH DO NOT SCALE DRAWING	UNLESS OTHERWISE SPECIFIED: .X = ±.030" .XX = ±.015" .XXX = ±.005" .XXXX = ±.002" X° = ±1° X.X° = ±0.5°	DRAWN: AKTIS DESIGNED: AKTIS SUPERCEDES: NONE SCALE: 1:24 & NOTED	DATE: 07-07-2020 DATE: 07-07-2020		PHASE: PRELIMINARY DESIGN	
		LAST MODIFIED IN: SOLIDWORKS 2017	COMMON SYMBOLS: R RADIUS Ø DIAMETER C CRITICAL TO FUNCTION () REFERENCE	INTERPRET PER ASME AND RAIN BIRD SPEC# 232397	DESIGN CONTROL SBU PLANT PROJ. NO. PROJ. NAME		FIRST USED ON	
		FILENAME: HO-I-14-PS-C.SLDDRW	TITLE: AUTOMATIC SELF CLEANING FILTER - HO-I-14-PS-C	A SIZE DWG. NO.	A.01 REV.			
		SHEET 1 OF 1						