

STANDARD DRAWING
5/13/2019

POWER REQUIREMENTS MUST BE SPECIFIED:

AVAILABLE STANDARD	
208	SINGLE PHASE
208	THREE PHASE
230	SINGLE PHASE
230	THREE PHASE
480	THREE PHASE

REFER TO PERFORMANCE FLOW CHART OR PUMP CURVE TO DETERMINE YOUR OPERATING FLOW AND PRESSURE COMBINATION

OPTIONS PURCHASED SEPARATELY	
6V DC (CLPPSR06DC)	PUMP START RELAY
12V DC (CLPPSR12DC)	
1Ø (CLPSES1P)	SURGE SUPPRESSION KIT
3Ø (CLPSES3P)	
CLPBSTSW	FLOW START KIT (BOOST PUMPS ONLY)
CLPFTVLV4VF	INTAKE SCREEN W/FOOT VALVE

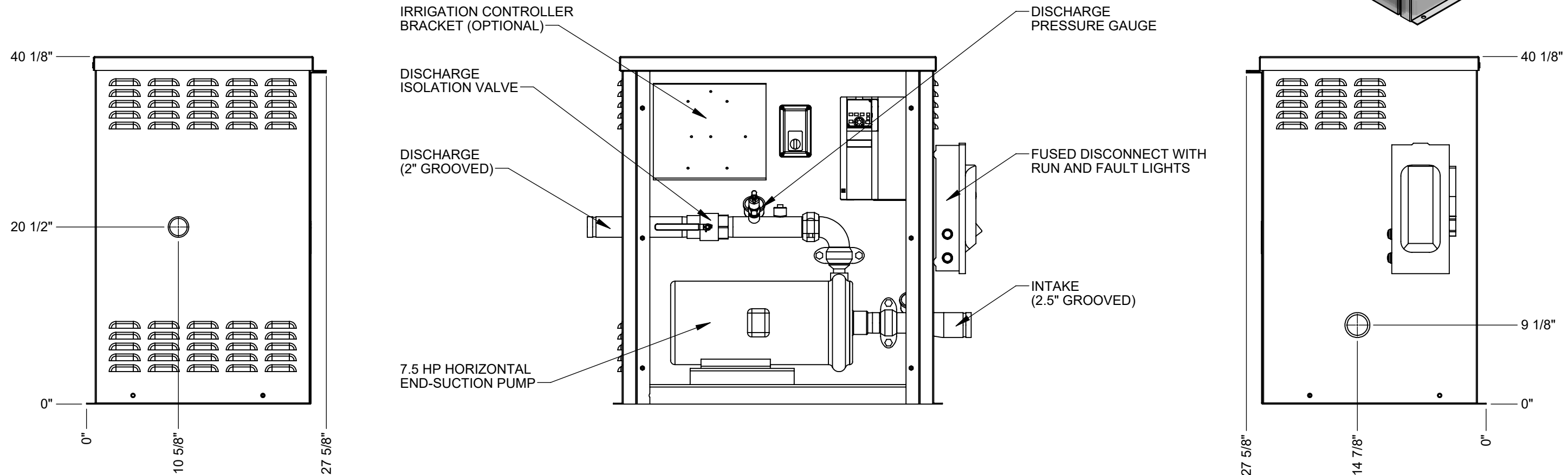
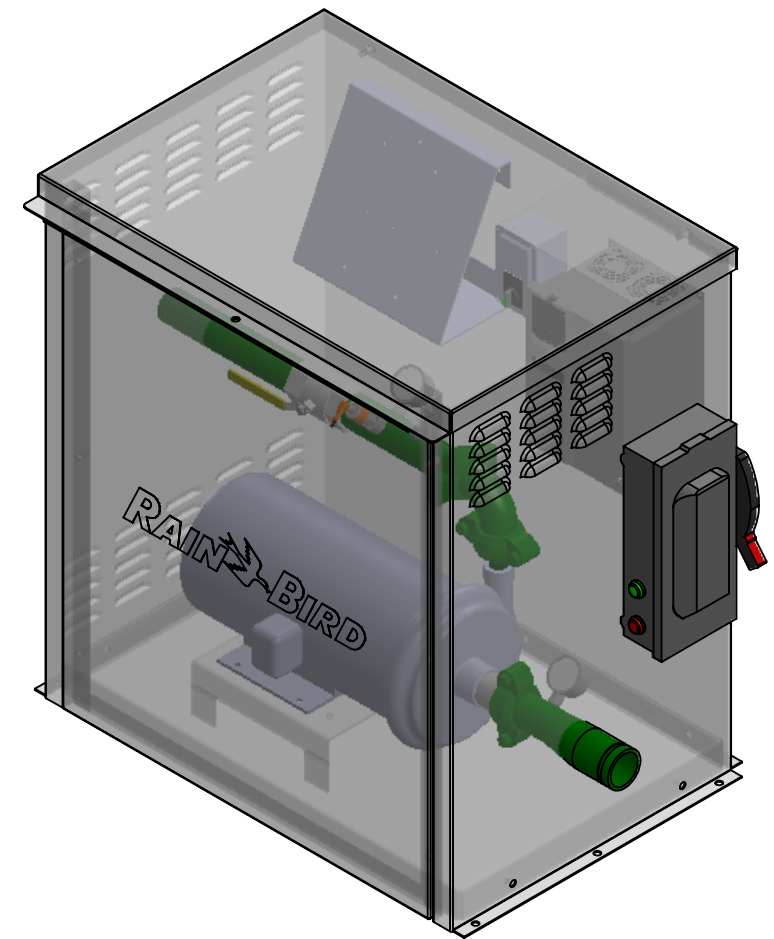
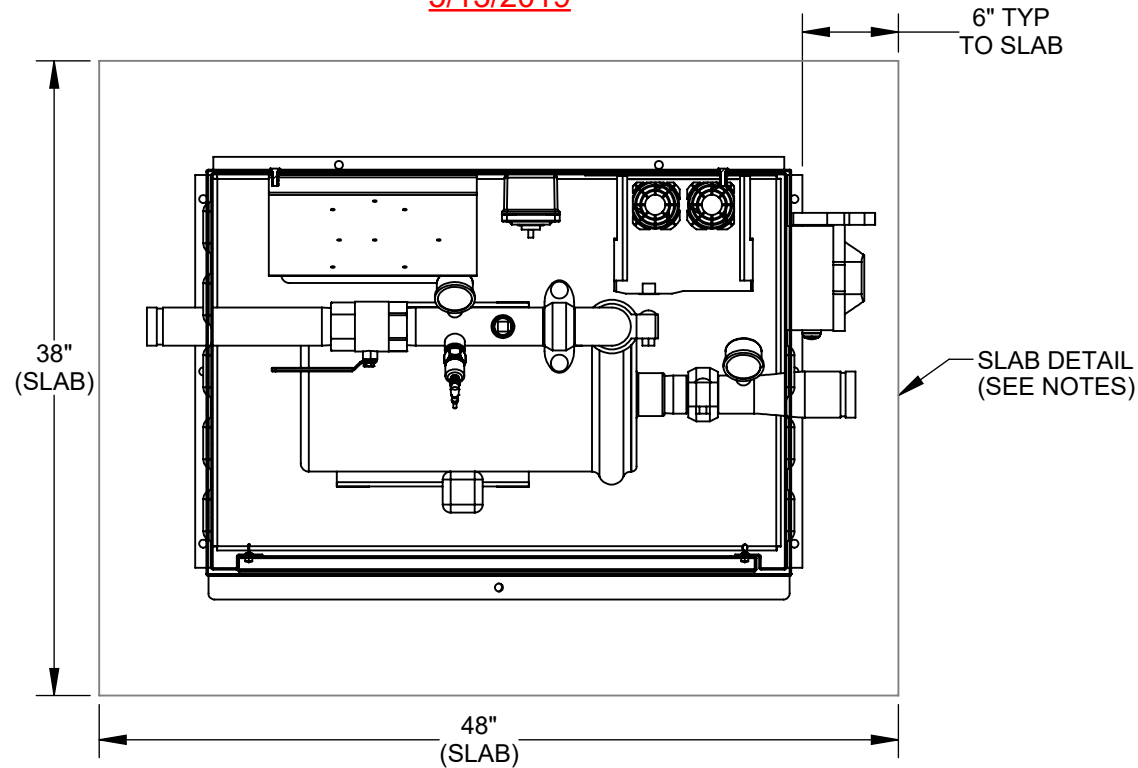

- NOTES:
1. SLAB DETAIL IS PROVIDED FOR ILLUSTRATION ONLY. THE ARCHITECT OR PROJECT ENGINEER SHOULD BE CONSULTED FOR CONSTRUCTION DETAIL.
 2. DIMENSIONS ARE FOR REFERENCE ONLY. EXTERNAL PLUMBING TO BE FIELD FIT.
 3. STATION WEIGHS ~ 250 LBS.

STANDARD DRAWING

<p>NOTICE:</p> <p>THIS DRAWING EMBODIES A CONFIDENTIAL PROPRIETARY DESIGN ORIGINATED BY RAIN BIRD CORPORATION. ALL DESIGN, MANUFACTURING, USE AND SALE RIGHTS REGARDING THE SAME ARE EXPRESSLY RESERVED. IT IS SUBMITTED UNDER A CONFIDENTIAL RELATIONSHIP FOR A SPECIFIC PURPOSE AND THE RECIPIENT AGREES BY ACCEPTING THIS DRAWING NOT TO SUPPLY OR DISCLOSE ANY INFORMATION REGARDING IT TO ANY UNAUTHORIZED PERSON, OR TO INCORPORATE IN OTHER PROJECTS ANY SPECIAL FEATURE UNIQUE TO THIS DESIGN. ALL PATENT RIGHTS HERETO ARE EXPRESSLY RESERVED.</p>	<p>UNLESS OTHERWISE SPECIFIED:</p> <p>FRACTIONAL TOLERANCE = ± 1/8"</p> <p>DRILLED HOLE Ø = ± 1/32"</p> <p>ANGULAR = ± 2°</p> <p>DECIMAL TOLERANCE X .XX = ± .001" XXX = ± .010"</p>	<p>DRAWN IB DATE 05/07/2019</p> <p>DESIGNED IB DATE 05/07/2019</p>	<p>DATE 05/07/2019</p>	<p>PROJ NAME N/A</p>	
		<p>SCALE 1:12</p>	<p>DO NOT SCALE DRAWING</p>	<p>TITLE CLP, 7.5HP</p>	<p>PROJ NO. N/A</p>
		<p>LAST MODIFIED IN VERSION SolidWorks 2017</p>	<p>DWG SYMBOLS PER ANSI</p>	<p>SYSTEMS MFG. DIV. TUCSON, ARIZONA</p>	<p>DRAWING NUMBER STANDARD - A</p>
		<p>CLP07JAC</p>	<p>SHEET 1 OF 3</p>	<p>REV.</p>	

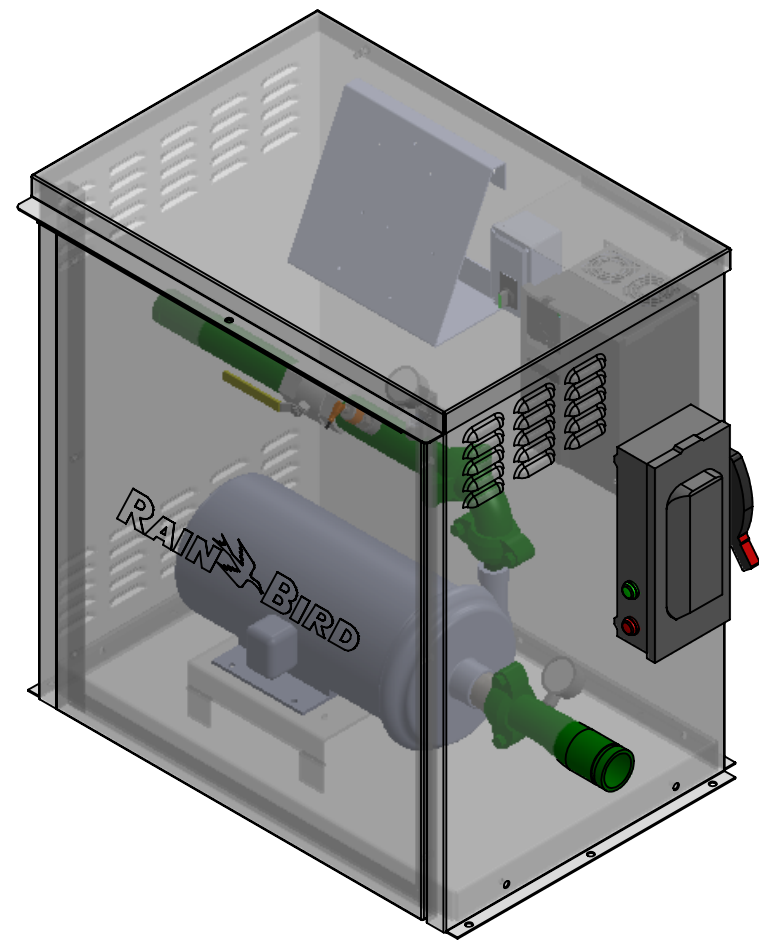

1. CLOSE-COUPLED, HORIZONTAL END-SUCTION PUMP WITH BRONZE IMPELLER AND TYPE 21 BUNA-N MECHANICAL SEAL FOR LONG PUMP LIFE.
2. NEMA-STANDARD FRAME, PREMIUM EFFICIENCY MOTOR WITH TOTALLY-ENCLOSED, FAN-COOLED CASE FOR SUPERIOR ENVIRONMENTAL PROTECTION.
3. ENERGY SAVING VARIABLE FREQUENCY DRIVE FEATURING INNOVATIVE RAIN BIRD PROGRAMMING; STATION WILL BE CONTROLLED VIA RELAY START INCLUDED STANDARD OR OPTIONAL FLOW START KIT.
4. 0-250 PSI STAINLESS STEEL PRESSURE TRANSDUCER REGULATES PRESSURE AT A USER-DEFINED SETPOINT WHILE IRRIGATING. 2 1/2" LIQUID GLYCERIN-FILLED SUCTION AND DISCHARGE PRESSURE GAUGES ARE STANDARD.
5. INCLUDES JUNCTION BOX WITH AUTO-OFF-MANUAL SWITCH AND 24 VAC PUMP START RELAY STANDARD; 12 OR 6 VDC PUMP START RELAY OPTIONS ARE AVAILABLE.
6. FUSED ELECTRICAL DISCONNECT INCLUDES EXTERNAL RUN AND FAULT INDICATOR LIGHTS AND DISCONNECT HANDLE FOR ISOLATING POWER TO THE STATION.
7. STATION IS BUILT USING ROBUST SCHEDULE 40 PIPING WITH HIGHLY DURABLE POLYESTER POWDER-COATING INSIDE AND OUT, AND GROOVED CONNECTIONS FOR EASY MAINTENANCE AND SERVICEABILITY.
8. FULL-PORT STAINLESS STEEL DISCHARGE ISOLATION VALVE STANDARD.
9. PUMP STATION IS CONTAINED IN A MARINE-GRADE ALUMINUM DECK AND ENCLOSURE WITH LOCKABLE HINGED LID, AND REMOVABLE FRONT PANEL FOR EASE OF MAINTENANCE.
10. EACH PUMP STATION IS FACTORY TESTED UNDER DYNAMIC CONDITIONS BEFORE SHIPPING.

NOTICE: THIS DRAWING EMBODIES A CONFIDENTIAL PROPRIETARY DESIGN ORIGINATED BY RAIN BIRD CORPORATION. ALL DESIGN, MANUFACTURING, USE AND SALE RIGHTS REGARDING THE SAME ARE EXPRESSLY RESERVED. IT IS SUBMITTED UNDER A CONFIDENTIAL RELATIONSHIP FOR A SPECIFIC PURPOSE AND THE RECIPIENT AGREES BY ACCEPTING THIS DRAWING NOT TO SUPPLY OR DISCLOSE ANY INFORMATION REGARDING IT TO ANY UNAUTHORIZED PERSON, OR TO INCORPORATE IN OTHER PROJECTS ANY SPECIAL FEATURE UNIQUE TO THIS DESIGN. ALL PATENT RIGHTS HERETO ARE EXPRESSLY RESERVED.	UNLESS OTHERWISE SPECIFIED: FRACTIONAL TOLERANCE = ± 1/8" DRILLED HOLE Ø = ± 1/32" ANGULAR = ± 2" DECIMAL TOLERANCE X = ± .007 XXX = ± .010"	DRAWN IB DATE 05/07/2019 DESIGNED IB DATE 05/07/2019 SCALE 1:12 DO NOT SCALE DRAWING LAST MODIFIED IN VERSION: SolidWorks 2017 DWG SYMBOLS PER ANSI	 SYSTEMS MFG. DIV. TUCSON, ARIZONA	PROJ NAME N/A PROJ NO. N/A
	TITLE CLP, 7.5HP			DRAWING NUMBER STANDARD -
	CLP07JAC			PART NO. REV. SHEET 3 OF 3