

Rain Bird Series Channel Drain

Complete Residential/Commercial drainage systems. Engineered to be worthy of the Rain Bird name.

For decades, Rain Bird has been finding new ways to use water more intelligently. We're proud to introduce a few more: Rain Bird Channel Drain products.



Strength by Design

Using design influences from the world's strongest bridges, a Diamond Lattice sidewall design was incorporated to give greater durability, strength, and stiffness.

Faster Installs

Self-Leveling feet prevent floating and requires less concrete to support vehicles. Clip-in Grates for fast and easy installation.

Options You Need

Available in 1-meter lengths , T-sections, corners, and in-line pits.



Rain Bird Series Channel Drain

Ruggedly constructed and designed to work together, Rain Bird's complete line of drainage products can help you efficiently manage water run-off and surface drainage for virtually any residential, commercial or municipal site. Put them in the ground. You'll see why they're worthy of the Rain Bird name.

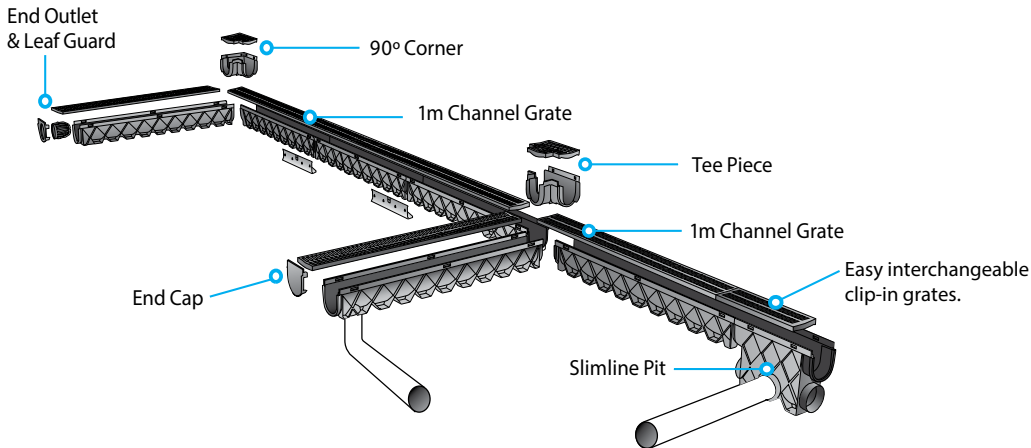

Rain Bird Engineered Channel Drain Systems are designed with the Professional in mind. 5" wide systems with the accessories you need, designed to save time and money.

Rain Bird 5" Standard Channel Drain



Rain Bird Standard 5" Channel Drain is the complete professional drainage system designed for paths, driveways, and other areas with corners and tee sections. With a complete range of accessories, and our clip-in grate design, our product is designed to make life easy. Available accessories: end cap, outlet, tee, corner, leaf guard, in-line pit.

Rain Bird 5" Low Profile Channel Drain



Rain Bird Low Profile 5" Channel Drain is our inline drainage solution. Perfect for paths, driveways and smaller spaces because it is lightweight, durable and UV stabilized. The hold-down feet and pipe cut-outs make it simple to install. Easily clips together, no joiners required. For inline use only. Available accessories: leaf guard and end cap.



Product Features

- Ideal for parking lots, sidewalks, and driveways
- Designed to withstand 5 ton vehicle load when installed in concrete
- Tough durable UV stabilized plastic
- Available in 1-meter lengths
- Clip in grates, no screws required
- Hold-down, self-leveling feet prevent floatation
- Bottom and end outlets can be glued to PVC pipe
- Bottom outlets can be drilled to fit standard 4" PVC and corrugated pipe
- Leaf guards available

