

CHOOSING EQUIPMENT CALLOUT METHOD

CHOOSE EITHER LEADERS OR BUBBLE CALLOUTS BY TURNING ON THE APPROPRIATE LAYER:

TEXT_LEADERS

TEXT_BUBBLES

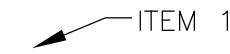

TO TURN OFF THIS INSTRUCTION BOX, TURN OFF LAYER "INSTRUCT-CALLOUT".

CHOOSING NOZZLES AND OPTIONAL FEATURES

NOZZLES

HE-VAN NOZZLE
MPR NOZZLE
ROTARY NOZZLE
SQ NOZZLE
U-SERIES NOZZLE
VAN NOZZLE

LAYER NAME

OPTION-NOZ-HEVAN
OPTION-NOZ-MPR
OPTION-NOZ-ROTARY
OPTION-NOZ-SQ
OPTION-NOZ-U-SERIES
OPTION-NOZ-VAN

OPTION

NON-POTABLE CAP
PRS 30PSI WITH FLOW SHIELD
PRS 30PSI WITH FLOW SHIELD NON-POTABLE CAP
SAM
SAM WITH NON-POTABLE CAP
SAM-PRS 45PSI WITH FLOW SHIELD
SAM-PRS 45PSI WITH FLOW SHIELD NON-POTABLE CAP
SAM-PRS 30PSI
SAM-PRS 30PSI WITH FLOW SHIELD
SAM-PRS 30PSI WITH FLOW SHIELD NON-POTABLE CAP

LAYER NAME

OPTION-NP
OPTION-PRS-F
OPTION-PRS-F-NP
OPTION-SAM
OPTION-SAM-NP
OPTION-SAM-P45-F
OPTION-SAM-P45-F-NP
OPTION-SAM-PRS
OPTION-SAM-PRS-F
OPTION-SAM-PRS-F-NP

CONTRACTOR ASSEMBLED SWING ASSEMBLY
RAIN BIRD SWING ASSEMBLY

LAYER

OPTION-SA
OPTION-RB-SA

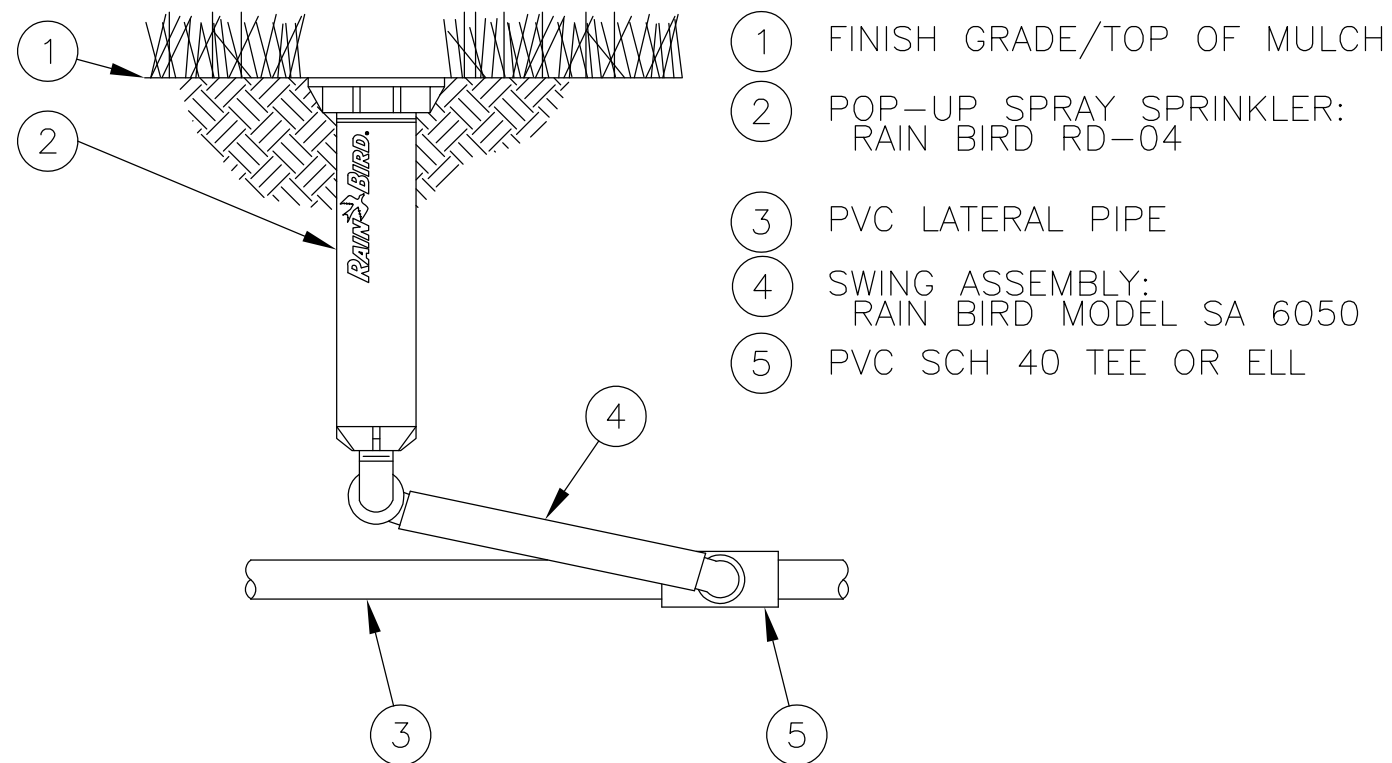

D

POP-UP SPRAY SPRINKLER
RD-04 WITH SWING PIPE

N.T.S.

10-17-2011