



## IMS Series Centrifugal Sand Separators

### Centrifugal Removal of Sand, Silt and Gravel from Water

Rain Bird Centrifugal Sand Separators are ideal for removal of suspended solids and inorganic materials with a specific gravity of 2 or greater. This highly effective system will provide consistent, simple removal of inorganic material down to 75 microns. Easily installed, these carbon steel units are rated to 150 psi with threaded or flanged inlet/outlet connections. Smaller models are designed for vertical installation while larger models are angled for floor or ground mounting.

**Sizing must be within the specified flow range for proper centrifugal action.**

#### Advantages

- Multiple units can be installed in series to provide higher filtration efficiency.
- Ability to disassemble unit for inspection through flanged manway.

#### Standard assembly includes:

- Welded carbon steel
  - Vertical models include female threaded inlet and outlet connections and a threaded purge port for purging of contaminants.
  - Angled models include flanged inlet and outlet connections and a threaded purge port for purging of contaminants.

#### Available options:

- Larger flow separators and custom designed systems are available.
- Units are available in ASME code or non-code construction.
- Available with an automatic solids purge valve system for flushing.
- Optional high pressure systems.
- Special alloys and coatings are available for prolonged life in special applications.
- Wall-mount kit for smaller units.



Angled Centrifugal Sand Separators Specifications						
Model	Minimum Flow		Maximum Flow		Inlet/Outlet ANSI 150# Raised Face Flange	Purge Port
	gpm	m <sup>3</sup> /hr	gpm	m <sup>3</sup> /hr	(in)	(in)
IMS-40LA	200	45	400	91	4"	2"
IMS-60LA	365	83	960	218	6"	2"
IMS-80LA	800	182	1600	364	8"	2"
IMS-100LA	1300	295	2300	523	10"	2"
IMS-120LA	2025	460	3400	773	12"	2"
IMS-140LA	2975	676	5000	1136	14"	2"
IMS-160LA	4000	909	6200	1409	16"	2"
IMS-180LA	5100	1159	8300	1886	18"	2"

Vertical Centrifugal Sand Separators Specifications						
Model	Minimum Flow		Maximum Flow		Inlet/Outlet NPT Threaded	Purge Port
	gpm	m <sup>3</sup> /hr	gpm	m <sup>3</sup> /hr	(in)	(in)
IMS-5V	4	1	10	2	1/2"	1"
IMS-7V	10	2	20	5	3/4"	1"
IMS-10V	18	4	38	9	1"	1"
IMS-12V	26	6	52	12	1 1/4"	1"
IMS-15V	38	9	79	18	1 1/2"	1"
IMS-20V	63	14	120	27	2"	2"
IMS-25V	100	23	180	41	2 1/2"	2"
IMS-30V	125	28	260	59	3"	2"
IMS-40V	190	43	345	78	4"	2"

# INDUSTRIAL • MUNICIPAL

## Angled Centrifugal Sand Separators Dimensions

Model	A	B	C	D	E	F	G	H	I	J	K	Particle Size Maximum
IMS-40LA	48 1/2"	46 1/2"	46 1/2"	16 11/16"	16"	7 1/2"	19"	4"	6 5/8"	12"	80"	1 1/2"
IMS-60LA	63"	59 1/2"	60 3/8"	20 1/2"	20 3/4"	10 1/2"	22"	5 1/4"	10 3/4"	16"	106 1/4"	1 1/2"
IMS-80LA	71"	65"	66"	21 3/4"	22 5/8"	12"	24 1/2"	5 5/8"	12 3/4"	18"	114"	1 1/2"
IMS-100LA	78"	71"	72 3/4"	21"	24 1/2"	13"	29"	7"	16"	22"	123 1/2"	1 1/2"
IMS-120LA	102"	75 1/4"	76 1/2"	23 3/4"	26 5/8"	14 1/4"	32"	8 1/8"	18"	26"	139"	1 1/2"
IMS-140LA	102 1/2"	85 3/8"	86 5/8"	24 1/2"	27 3/4"	12"	33 1/2"	9"	20"	28"	152 1/2"	2"
IMS-160LA	108"	89 1/4"	90"	24 3/8"	29"	12"	33 1/2"	9"	24"	30"	160"	2"
IMS-180LA	118 1/2"	98 1/4"	100 1/4"	27"	33 5/8"	15"	34 1/2"	11"	28"	36"	177"	2"

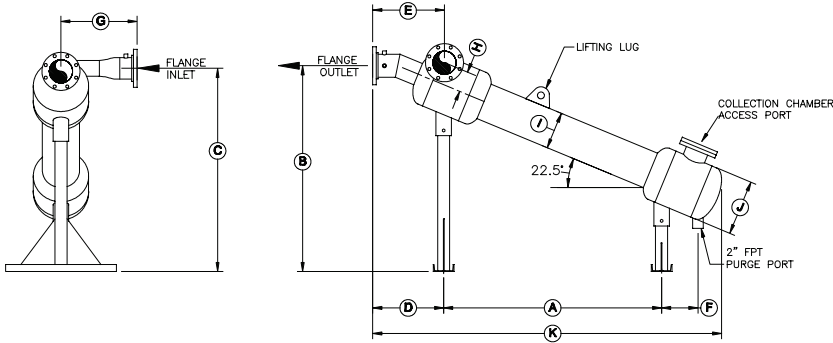

## Vertical Centrifugal Sand Separators Dimensions

Model	A	B	C	D
IMS-5V	21 1/2"	6"	2 3/8"	2 1/2"
IMS-7V	21 1/2"	6"	2 3/8"	2 1/2"
IMS-10V	30 1/2"	6"	3 1/2"	2 3/4"
IMS-12V	30 1/2"	6"	3 1/2"	3"
IMS-15V	30 1/2"	6"	3 1/2"	3 1/8"
IMS-20V	38"	8"	4 1/2"	3 5/8"
IMS-25V	43 3/4"	10"	4 1/2"	4 1/2"
IMS-30V	47 1/2"	10"	5 9/16"	5"
IMS-40V	49"	12"	6 5/8"	6"

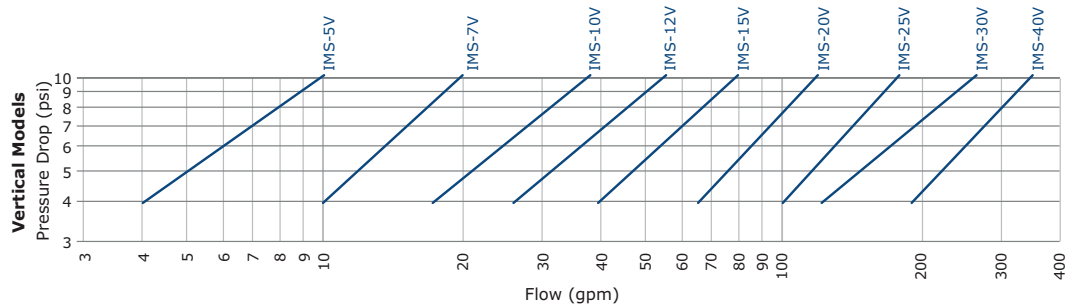
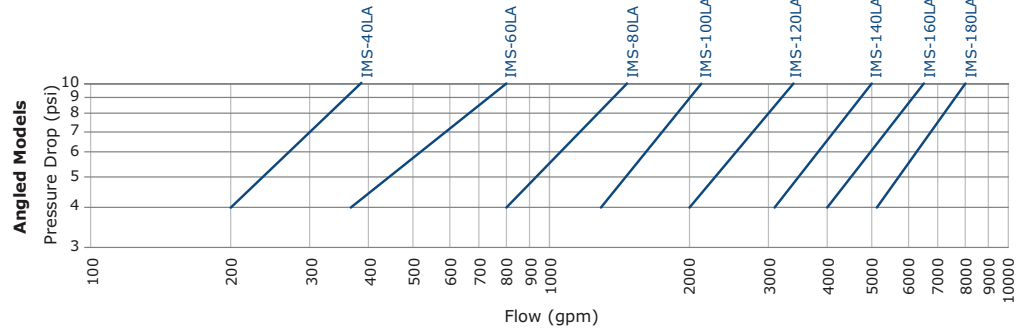
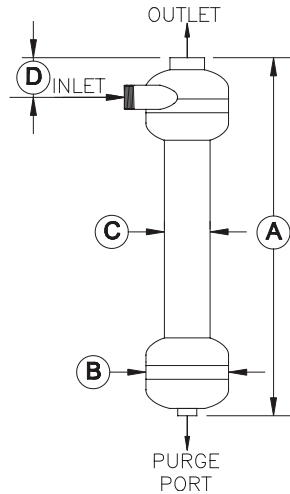

**Rain Bird Corporation**  
 6991 E. Southpoint Road  
 Tucson, AZ 85756  
 Phone: (520) 741-6523  
 Fax: (520) 806-5678

**Rain Bird Corporation**  
 970 West Sierra Madre Avenue  
 Azusa, CA 91702

**Rain Bird International, Inc.**  
 1000 West Sierra Madre Ave.  
 Azusa, CA 91702

[www.rainbird.com](http://www.rainbird.com)  
[www.industrial.rainbird.com](http://www.industrial.rainbird.com)

The Intelligent Use of Water™