

ESP-LX+ & ESP-LX+ CONTROLLER FAMILY
ESP-6LX+RR / ESP-8LX+RR / ESP-12LX+RR / ESP-16LX+RR

FRONT PANEL

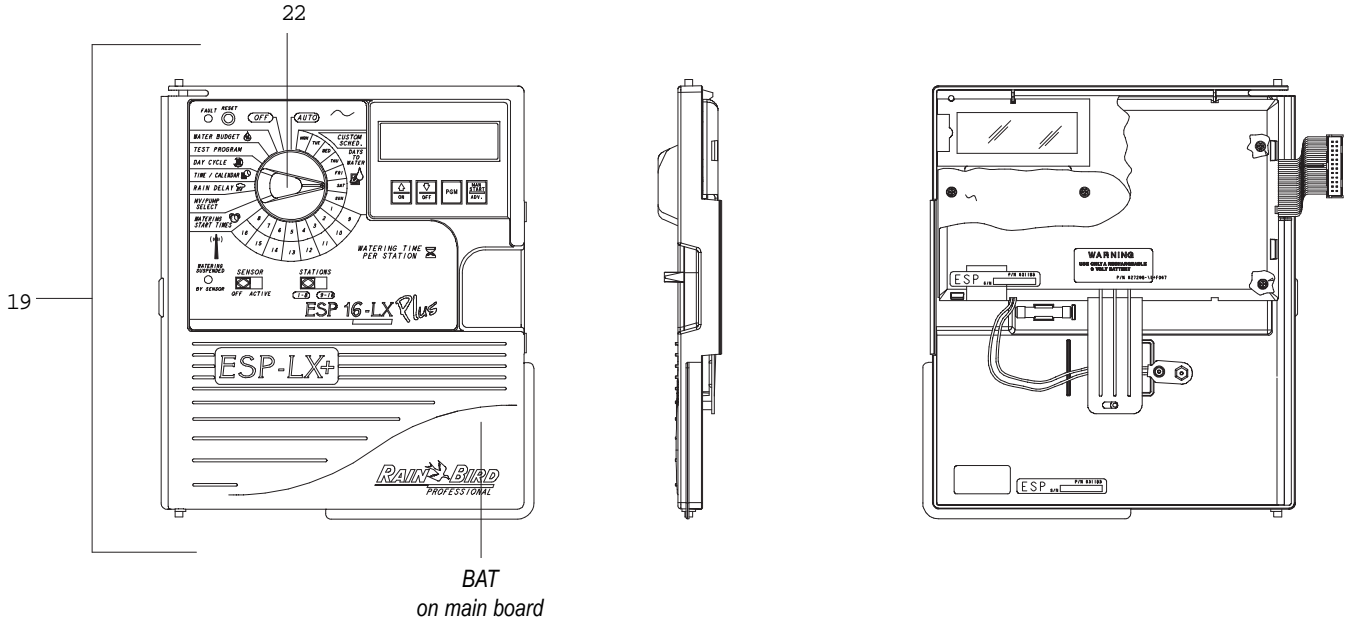

CASE

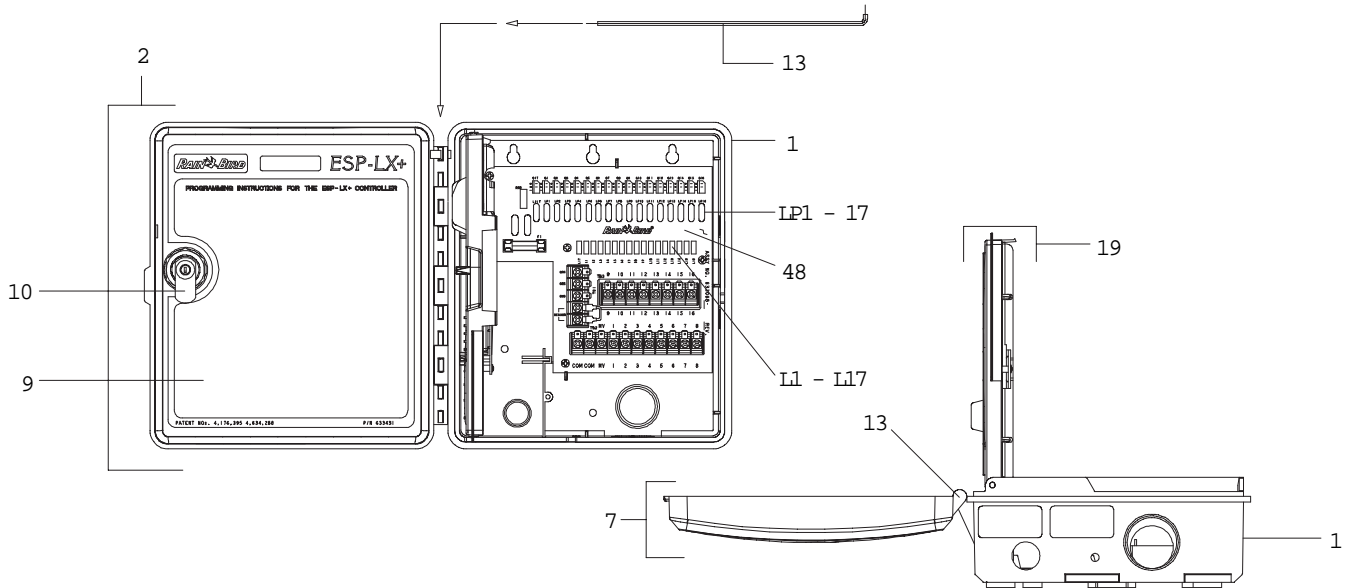

Note: Part numbers enclosed in brackets () are not available individually, but may be sold in assemblies or kits.

ESP-LX+ & ESP-LX+ CONTROLLER FAMILY ESP-6LX+RR / ESP-8LX+RR / ESP-12LX+RR / ESP-16LX+RR

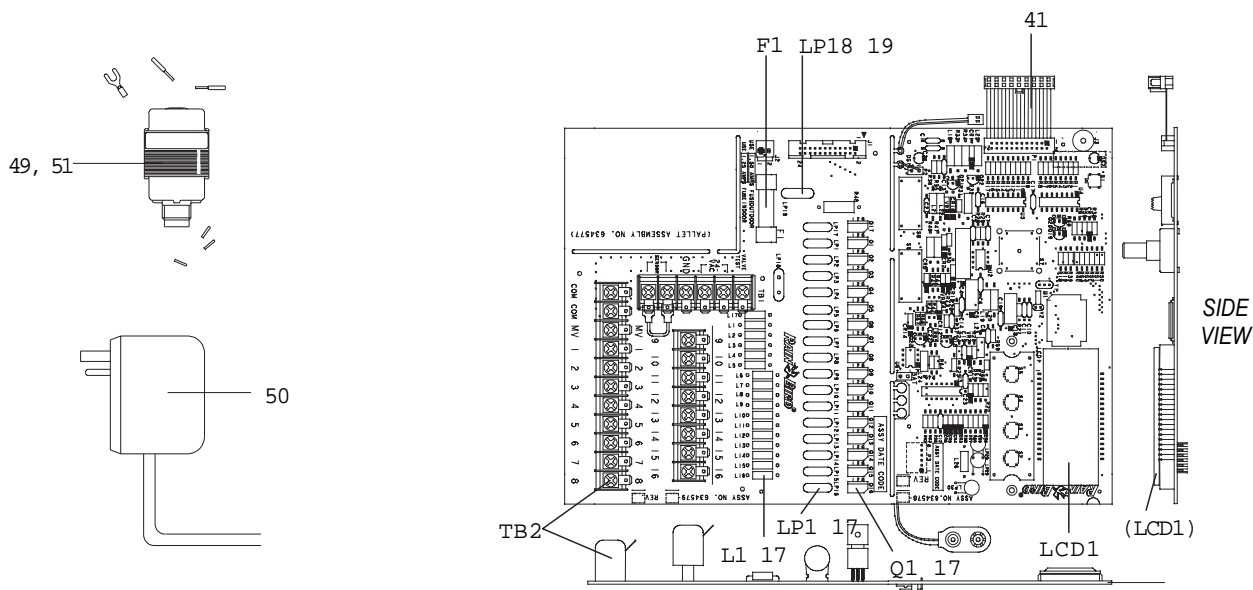

Ref.	Description	Qty.	ESP-6LX+	ESP-8LX+	ESP-12LX+	ESP-16LX+
1	CABINET ASSEMBLY					
2	Case, ESP-LX+	1	631750	631750	631750	631750
3	General Information	1	634214	634214	634214	634214
4	FCC compliance label	1	633662	633662	633662	633662
5	Rivet Blind 0.19	1	(650434-13)	(650434-13)	(650434-13)	(650434-13)
6	Caution Label (International Units only)	1	633657	633657	633657	633657
7	DOOR ASSEMBLY ESP-LX+	1	633430	633430	633430	633430
8	Door ESP-LX+	1	631751	631751	631751	631751
9	Label programming ESP-LX+	1	633431	633431	633431	633431
10	Lock Cam	1	650755	650755	650755	650755
11	Screw PHL PNH HI-LO 6-19X3/8	5	(650183-46)	(650183-46)	(650183-46)	(650183-46)
12	Screw, 4-24 x 5/16 HI-LO w/WSHR	1	(650563-23)	(650563-23)	(650563-23)	(650563-23)
13	Hinge Pin	1	631757	631757	631757	631757
14	Washer, Nylon # 3 size	1	650878	650878	650878	650878
15	Cable Tie, Nylon 7/8 Bundle	1	650131	650131	650131	650131
16	Manual, holder hook Assembly	1	(635058-01)	(635058-01)	(635058-01)	(635058-01)
17	Manual holder hook	1	635056	635056	635056	635056
18	Conformable acrylic foam tape	1	635057	635057	635057	635057
19	FRONT PANEL ASSEMBLY ESP-LX+	1	K94020	K94120	K94220	K94320
20	Label warning CIC 8/12	1	(627298)	(627298)	(627298)	(627298)
21	Label Date Code and Serial Number	1	(635600-01)	(635600-01)	(635600-01)	(635600-01)
22	Funct. Select Knob Assy. Gray	1	630946	630946	630946	630946
23	Ring Compression	1	(650505-06)	(650505-06)	(650505-06)	(650505-06)
24	Button ,TM PB Swich	1	(631136)	(631136)	(631136)	(631136)
26	Switch Actuator- Paragon 6 & 8 Stations model	1	(632510)	(632510)	-	-
27	Switch Actuator- Paragon 12 & 16 Stations model	2	-	-	(632510)	(632510)
28	Lens ,LCD ESP-C/LX	1	(632700)	(632700)	(632700)	(632700)
29	Keypad Silicone	1	(632908)	(632908)	(632908)	(632908)
30	Cover/Shield, Assy. CPU	1	(632912-02)	(632912-02)	(632912-02)	(632912-02)
31	Cover, CPU Board- ESP-LX+	1	(632516)	(632516)	(632516)	(632516)
32	Shield, CPU Board Cover	1	(632911-02)	(632911-02)	(632911-02)	(632911-02)
33	Shield, Front Panel Assy.,ESP-LX+	1	(632914)	(632914)	(632914)	(632914)
34	Front Panel ESP-LX+	1	(632294)	(632294)	(632294)	(632294)
35	Shield Front Panel ESP-LX+	1	(632913)	(632913)	(632913)	(632913)

Note: Part numbers enclosed in brackets () are not available individually, but may be sold in assemblies or kits.

ESP-LXI+ & ESP-LX+ CONTROLLER FAMILY

ESP-6LX+RR / ESP-8LX+RR / ESP-12LX+RR / ESP-16LX+RR

Ref.	Description	Qty.	ESP-6LX+	ESP-8LX+	ESP-12LX+	ESP-16LX+
36	Control PWB Assembly ESP LX+	1	(634580-09)	(634580-10)	(634580-11)	(634580-12)
37	Label, Overlay ESPLX+	1	(633190-01)	(633190-02)	(633190-03)	(633190-04)
38	Label, Manual/Start Caution	1	(633676)	(633676)	(633676)	(633676)
39	Screw, 4-24 x 5/16 HI-LO W/WSHR	5	(650563-23)	(650563-24)	(650563-25)	(650563-26)
40	CABLE ASSEMBLIES					
41	Cable Harness Assy. Rushcab	1	(631762)	(631762)	(631762)	(631762)
42	Sensor Cable Assy.	1	(632048-02)	(632048-02)	(632048-02)	(632048-02)
43	CONTROL PWB ASSEMBLY ESP-LX+	1	635161-05	635161-06	635161-07	635161-08
S7	Switch Rotary	1	(630609)	(630609)	(630609)	(630609)
S6	Switch 4 POS Slide	1	-	-	(630651)	(630651)
S8	Switch 4 POS Slide	1	(630651)	(630651)	(630651)	(630651)
44	Label Bar Code 39, Date Code	1	(631356-01)	(631356-01)	(631356-01)	(631356-01)
45	Label MAT Brady .25x1.25	1	(632347-01)	(632347-01)	(632347-01)	(632347-01)
LCD1	Spacer LCD	1	(632046)	(632046)	(632046)	(632046)
J3	Spring Shield	1	(632898-01)	(632898-01)	(632898-01)	(632898-01)
J3	Spring Shield	1	(632898-02)	(632898-02)	(632898-02)	(632898-02)
48	TERMINAL PWB ASSEMBLY ESP-LX+	1	635936-01	635936-02	635936-03	635936-04
49	Outdoor Transformer 120V / 60HZ.	1	631661-01	631661-01	631661-01	631661-01
50	Indoor Transformer 120V / 60HZ	1	631507	631507	631507	631507
51	International Outdoor Transformer 230V / 50HZ.	1	633457-01	633457-01	633457-01	633457-01
52	Label, Bar code 39, Date Code	1	(631356-01)	(631356-01)	(631356-01)	(631356-01)
53	Label Mat. Brady .25x1.25	1	(632347-01)	(632347-01)	(632347-01)	(632347-01)
TB1	Sensor Jumper Wire-ESP-LX+	1	(631761)	(631761)	(631761)	(631761)
TB3	Spacer, Terminal Strip (Not used on current models)	1	-	-	(631659)	(631659)
TB1	Terminal Block, with protection, 6 Position	1	(634414)	(634414)	(634414)	(634414)
TB3	Terminal Block with spacer, 8 Position	1	-	-	(634413)	(634413)
TB2	Terminal Block, 11 Position	1	(631763-03)	(631763-03)	(631763-03)	(631763-03)
F1	Fuse, 1 1/2A 250V (Indoor & Outdoor Controllers)	1	650431-23	650431-23	650431-23	650431-23
56	ACCESSORIES					
57	Battery NIMH 9V	1	650929	650929	650929	650929
58	Chart, programming valve I.D. ESP-LX+	1	633474	633474	633474	633474
	Instruction Manual	1	634415	634415	634415	634415
	Instruction Manual (7 Languages)	1	634229	634229	634229	634229

Note: Part numbers enclosed in brackets () are not available individually, but may be sold in assemblies or kits.