

Vertical Turbine – 3 Pump – Large Deck

High Flow Pump Station – 3 Pumps on a single deck

40 to 75 HP per pump; Up to 140 psi (9.7 bar); Up to 2400 gpm (151 LPS, 545 m³/h)

Rain Bird's 3 pump, vertical turbine pump station on a polyester powder-coated deck is designed to be installed over wet wells or vaults. Vertical turbines offer the highest hydraulic efficiency available, leading to the lowest cost of ownership over the life of the system. With a PM pump for pressure maintenance and optional IP (Intermediate Pump), this station is well-suited for large Turf and Golf Course irrigation applications with flows up to 2400 gpm (151 LPS, 545 m³/h).

At-A-Glance Description

- **Energy efficient** – Vertical turbine pumps with Variable Frequency Drive (VFD) maintain constant pressure at varying flow demand.
- **High Flow capacity** – up to 2400 gpm at 110 psi (151 LPS, 545 m³/h at 7.6 bar)
- **Sophisticated control package** with enhanced PLC software, large color touch panel display and a choice of communication options for remote access, central control software integration-ready.
- **Choice of filtration options** and accessories.

Standard Features

- **Main Pumps**
 - Marine Bronze Impellers
 - Stainless Steel Vertical Line Shaft
 - Cast Iron, Porcelain Lined Bowls
 - 60K PSI Ductile Iron Head
- **Pressure Maintenance**
 - 5 HP PM pump - Submersible
- **Motors**
 - High Efficiency Motors, Weather Protected Type WP1, Class F insulation
 - Motor heaters
- **Mechanical Features**
 - Individual Pump Discharge Isolation Valves
 - Discharge Butterfly Isolation Valve
 - Silent Check Valve Per Pump
 - Pressure Relief Valve
 - Air Relief Valve per head
 - Pump Set Length longer than 15ft includes well service valves and larger deck
 - Hose bib
- **Pressure / Flow**
 - Stainless Steel Pressure Transducer
 - Paddle Wheel Flow Meter

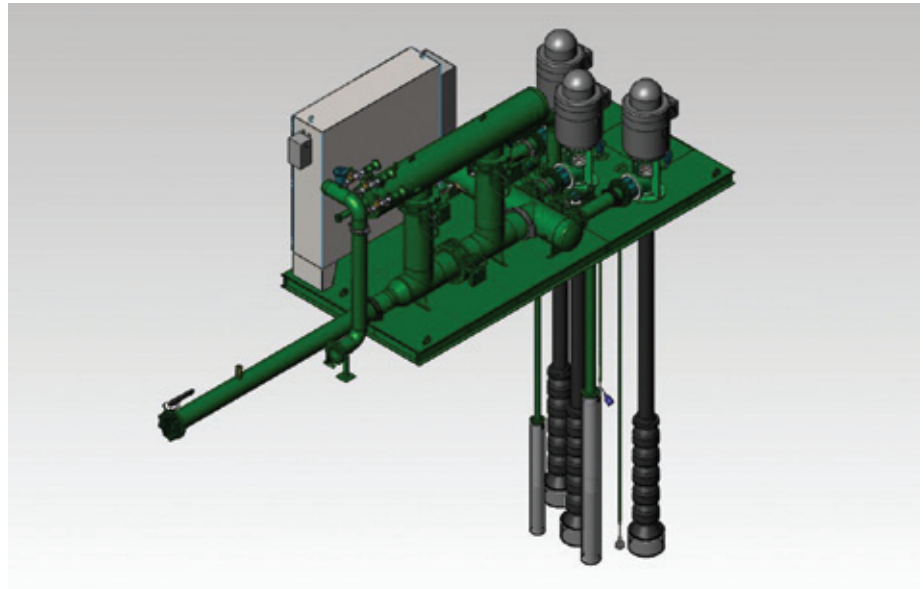

- **Enclosures / External Connections**
 - Polyester Powder-Coated Steel Deck and Piping
 - Integral Wet Well Service Hatch
 - NEMA 4 Electrical Enclosure
 - Heat Exchanger on Electrical Enclosure
 - **Pump Control**
 - VFD with pump rotation
 - **Display**
 - Illuminated, 3-position HOA switches
 - Resettable Circuit Breakers
 - 8.4 inch, Color Touch Panel Display
 - Ethernet port for VNC Connectivity
 - **PLC (Programmable Logic Control)**
 - Ethernet-ready PLC Control Package
- (continued on back)*

Vertical Turbine – 3 Pump – Large Deck

Motor Size	40 HP	50 HP	60 HP	75 HP
Power Requirement	230/60/3 V/HZ/PH			
	480/60/3 V/HZ/PH			
	415/50/3 V/HZ/PH			
	380/50/3 V/HZ/PH			
	575/60/3 V/HZ/PH			
Disconnect Size	400 Amp	400 Amp	400 Amp	400 Amp
Discharge Flow at 110 psi ⁽¹⁾	1200 GPM 75.7 LPS, 272 m ³ /hr	1500 GPM 94.6 LPS, 341 m ³ /hr	1800 GPM 113 LPS, 409 m ³ /h	2400 GPM 151 LPS, 545 m ³ /hr
Discharge Pipe	6"			
PM Pump	5 HP Submersible PM Pump - Standard			
Optional IP Pump	10 – 25 HP - Optional			
Deck Dimensions	7'0" x 16'0" (2.13 meters x 4.88 meters)			
Min Slab Dimension	13'6" x 22'0" minimum (4.1 meters x 6.7 meters minimum)			
Wet Well Diameter	72" Diameter (min) 1.8 meters (min)			
Pump Set Length	Up to 40 ft. (12.2 meters)			
Cabinet Height (from slab)	7'10" (239 cm)			

(1) Refer to pump performance curves, provided upon request from pumps@rainbird.com

Standard Features (cont.)

- **Lake Level Safety**
 - Low Level Shut Off (Float)

Optional Features

- **Main Pumps**
 - 316 SS or NiAl Bronze Impellers
 - 316 SS or Coal Tar Epoxy Coated Column Pipe
 - 316 SS, NiAl Bronze, or Coal Tar Epoxy Coated Bowls
- **Motors**
 - Premium Efficiency Motors
- **Pressure / Flow**
 - Magnetic Flow Meter

- **Pump Control**
 - VPM (VFD Per Motor)
- **Intermediate Pump**
 - 10-25 HP Intermediate Pump - Submersible
- **Panel Only**
 - Electrical Panel only (for retrofits)
- **Communications**
 - Ethernet Radio Modem Kit
 - Hardwire Ethernet Extender kit

- **Intake Filters**
 - SS Steel Box Screen
- **Enclosures / External Connections**
 - Air Conditioning on Electrical Cabinet
 - 5 kW room heater
 - Power Zone (3 kVA, 5 kVA, 10 kVA)
 - Custom Zee Pipe
- **Lake Level Control**
 - Lake Level Controls (Float or Analog)

Accessories

- **Filters**
 - 10" Wye Strainer Filter (1/8" openings)
 - 8" or 10" Backwashing Filter (250 μ)
 - 8" or 10" Suction Scanning Filter (300 μ)

Details

