

Horsepower: 1/2 HP 3/4 HP

Voltage: 115V 60 Hz 220V 50 Hz 230V 60 Hz

Cord Length: 50' Other: _____

Serial Number: _____

Running Voltage: _____ Amperage: _____



Rain Bird® Corporation
6991 East Southpoint Road
Tucson, AZ 85706
www.rainbird.com



**Lake Management Multi-Pattern
(LMM) Water Feature**
Owner's Manual





Contents

Water Feature Placement	2
Installation	3-6
Technical Specifications	7
Adjusting/Changing Spray Patterns and Accompanying Exploded View Diagrams	8-13
Trouble Shooting Guide	14
Maintenance	15
Winterization	15
Exploded View Diagram - Unit	16
Lighting System Specifications	17
Lighting System Installation	17-18
Light Bulb Replacement	18
Warranty	18

I. Water Feature Placement

When using your Water Feature for aesthetic enhancement only, position the Water Feature in the place you feel it is best suited. When using your Water Feature for water aeration choose the LM11 Series pattern and place the Water Feature as shown below.

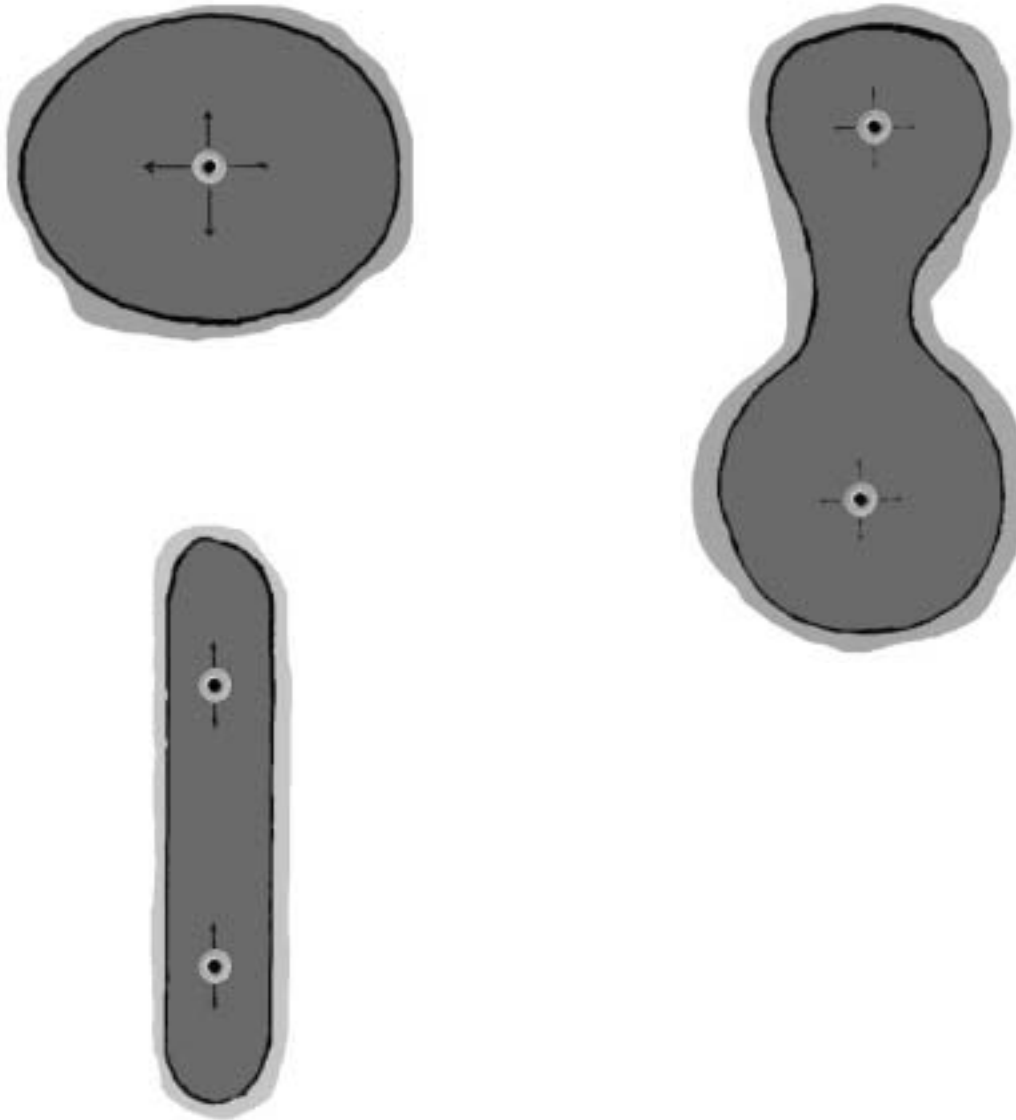



II. Unit Installation

- A. Unpack and inspect your Water Feature. Remove the protective cardboard ring around the top of the unit. Report any shipping damage to the carrier who delivered your Rain Bird Water Feature. Verify you have received the following:
1. **Water Feature** - You will find a label located on the inner motor housing. This label can be read through the screen. Check to make sure you have received the correct horsepower and voltage. The Water Feature comes standard with 50 ft (15 m) of power cable. If a custom length was specified, verify you have received the proper length.
 2. **Power Control Center** - A mini power control center is standard on all 60 Hz Water Features. If your unit is 60 Hz, verify the control center is present. On 50 Hz units, the panel is optional. If ordered, verify the panel is of the proper voltage and frequency.
 3. **Hardware Kit** - Included in this kit are two mooring/anchor clips, a LM11 series spray nozzle, two cable ties and one 1/8" Allen wrench.
 4. **Optional Light Kit** - If lights were ordered, verify the proper number of lights and a light power control center are enclosed.
- B. Prior to installation, please measure your water depth. All Rain Bird LMM Water Features require at least 18" or 0.5 m of water to run properly. If the water is too shallow, dig out a portion of the pond bottom directly under the Water Feature. If high waves or large fluctuations in depth occur, it will be necessary to allow for more than the required 18" or 0.5 m.
- C. Pattern Selection: your Rain Bird Water Feature has been factory configured with the LM20 Series spray pattern. If the LM11 Series or LM10 Series pattern is desired, refer to the **"Adjusting/changing spray pattern section"** of this manual and change the pattern at this time.

- D. Light Kit: lights are optional on your Water Feature. If ordered with your unit, they should be installed on the Water Feature at this time. Electrical installation must be completed by a qualified licensed electrician. Refer to the **Light Installation** section of this manual.

III. Electrical Installation



WARNING: To prevent fatal or serious electrical shock, this equipment must be installed:

- By a licensed electrician
 - In compliance with national and local electrical codes
 - With the proper size fusing and/or circuit breaker protection
 - With 5 milliamp ground fault protection (GFCI)
- A. Your Water Feature is safety tested and ETL, ETLIC and CE listed. However, proper installation is the most crucial step to assure a safe and reliable unit.
- B. Install Rain Bird Power Control Panel as close to the pond as possible. The enclosure is rated for both indoor and outdoor use. Mount panel a minimum of 3' (1 m) above the ground and above any flood zone. Always keep the panel door closed.

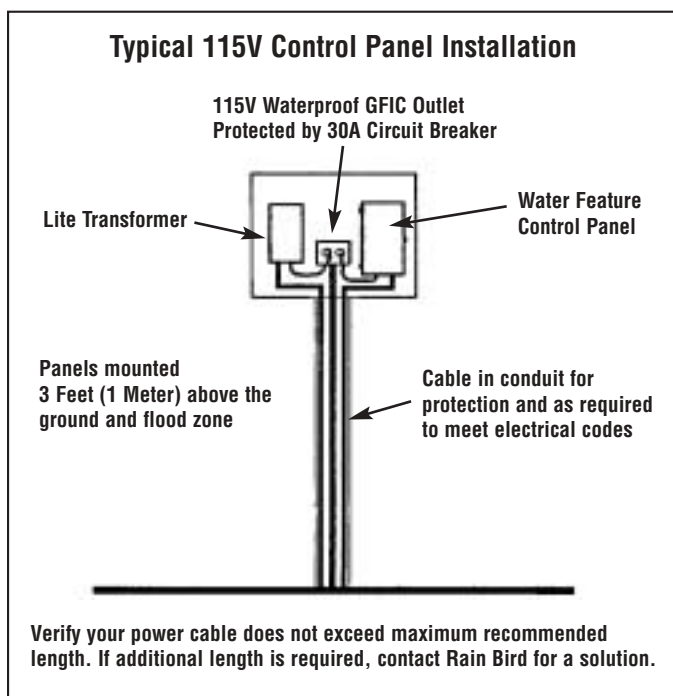

CAUTION: The power control panel must not be accessible from the water.

Maximum Cable Length			
Horse Power	Voltage	Frequency (Hz)	Maximum Length #12 Cable
1/2	115	60	125' or 37.8 m
1/2	230	60	480' or 146.3 m
1/2	220	50	700' or 213.4 m
3/4	230	60	350' or 106.7 m

C. Have a licensed, qualified electrician install the proper size fusing and/or circuit breaker protection as listed below. All work must be done in compliance with national and local electrical codes.



NOTE: The 230V panel includes the proper fusing.

Proper Fusing				
Horse Power	Voltage	Frequency (Hz)	Circuit Breaker Size (Amps)	Slow-Blow/Delay Fuse Size (Amps)
1/2	115	60	30	20
1/2	230	60	15	10
1/2	220	50	15	10
3/4	230	60	20	15

D. Have the electrician connect the power control center to the power source.



NOTE: For 115V units, a plug is supplied with the panel. This plug must be attached to the Water Feature cable and installed only into the power control panel.

WARNING: Never run the Water Feature out of the water. **Running the unit out of the water may damage the motor and void warranty.**

CAUTION: Keep hands clear of the impeller when trying to start the water feature.



E. Physically disconnect the power cable from its source and proceed with the installation of the unit.

DANGER: Thermally protected automatic reset.

- Unit will restart without warning after protection trips.
- Keep fingers out of impeller system until unit is disconnected.
- Always disconnect unit from power source before servicing.



NOTE: This unit contains thermal protection to help prevent intense heat conditions in the motor that could damage the motor. If your unit is intermittently starting and stopping, the unit is showing symptoms of a larger problem and you should disconnect power from the unit and call your local service center.

IV. Physical Installation

NOTE: Your Rain Bird Water Feature may either be moored or anchored in the water. Mooring is the preferred method as it provides an easy method to retrieve the unit and allows for fluctuations in water height.

WARNING: Do not use the power cable as a mooring line.

- A. The hardware kit supplied with your unit includes 2 mooring clips. These clips are designed to slide into any of the 6 slots in the bottom of the float cover.
- B. Install two mooring clips on opposite sides of the unit. Fasten the clips from the inside so that the holes are on the outside. Refer to figure below.

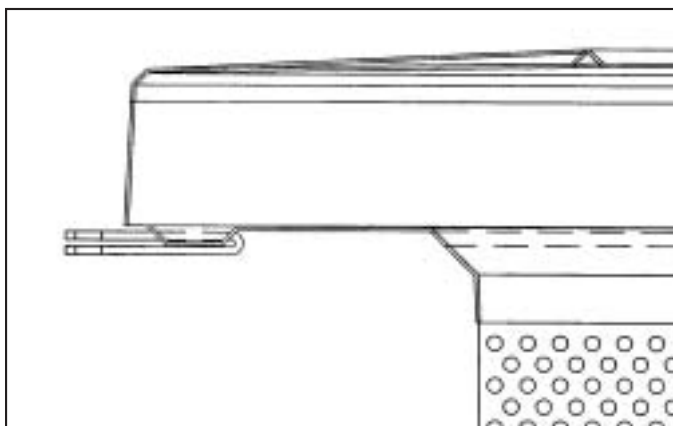

- C. Using cable tie supplied, secure power cord to one of the cable tie mounts on the bottom of the unit.

D. Mooring the Water Feature.

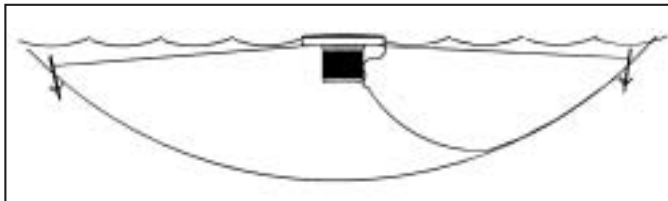

1. The following is required to moor your Rain Bird Water Feature.

- a. 1/4" or 6.3 mm polypropylene rope or 1/8" stainless steel cable for use as mooring lines.



NOTE: Use all brass or stainless steel hardware.

- b. For mooring points, either wooden stakes, 1/2" or 125 mm rebar, or "duckbill" type earth anchors.

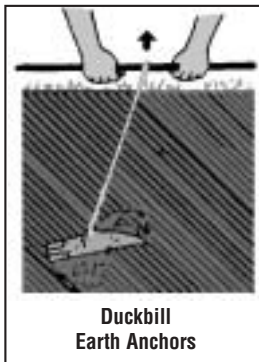

Duckbill Earth Anchors are driven into the ground, using a drive rod and heavy hammer, compacting the earth as they drive downward, until they reach the recommended depth. After removing drive rod, installer pulls up on cable. This planes or rotates the anchor into load lock

position, like a toggle bolt in undisturbed earth.

2. Choose a suitable location for your water feature. Refer to the "**Water Feature Placement**" section of this manual.
3. Secure your first mooring point. If you are using a stake or rebar, make sure to pound the mooring point securely into the ground on outer edge of the pond. If you are mooring with an earth anchor, you will need to place the earth anchor two feet into the pond, below the surface of the water, and then pound the earth anchor two feet into the pond bottom. The earth anchor will allow your mooring lines to be virtually unnoticeable as it will be hidden beneath the water surface.
4. Attach the mooring lines to the mooring clips on the Water Feature.
5. Carefully, place the Water Feature into the water.

Mooring the Water Feature-Continued

6. Walk one mooring line around to the far edge of the pond and pull the Water Feature into the desired location.
 7. Secure your second mooring point. Attach the line/cable leaving enough slack in the lines to allow the Water Feature to turn 120 degrees or 1/3 turn. This slack will allow for proper start-up, wave action and fluctuations in the water level.
 8. Proceed to **“Final Electrical Installation”** instructions in this manual.
- E. Anchoring the Water Feature.

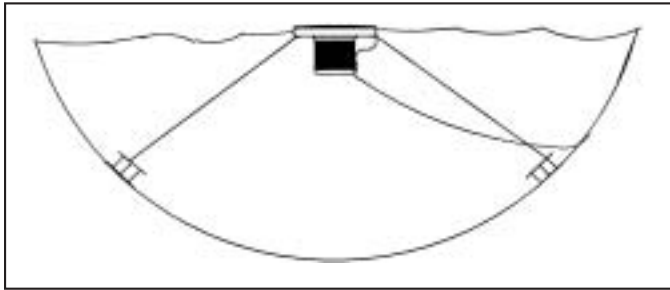

1. The following is required to anchor your Rain Bird Water Feature:
 - a. 1/4" or 6.3 mm polypropylene rope or 1/8" stainless steel cable for use as anchor lines.
-  **NOTE:** Use all brass or stainless steel hardware.
- b. Two 15 lb or 8 kg anchors.
2. Choose a suitable location for your Water Feature. Refer to the **“Water Feature Placement”** section of this manual.
 3. Using a boat, take the Water Feature and anchors to the chosen location.
 4. Drop the anchors (with anchor lines attached) out of the boat at a minimum of a 45 degree angle from the desired location of the Water Feature. See figure above.
 5. Bring the anchor lines together and secure each of them to the corresponding anchor clip on the Water Feature. Attach the line/cable leaving enough slack in the lines to allow the Water Feature to turn 120 degrees or 1/3 turn. This slack will allow for proper startup, wave action and fluctuations in the water level.

V. Final Electrical Installation



CAUTION: All electrical work must be done by a qualified, licensed electrician.

- A. With the Water Feature securely moored or anchored, re-attach the power cable to the source of electricity.



NOTE: Rain Bird suggests that the power cable be encased in conduit when placed underground. The Water Feature's underwater power cable should be encased in conduit from the power source to approximately 3-4' or 1 m out into the water, this insures against possible cable damage.

- B. Apply power to the unit. With the unit running, have the licensed electrician conduct a voltage and amperage reading. Verify your unit is receiving the proper voltage. Record the voltage and amperage readings on the back cover of this manual.
- C. Test the GFCI device for proper operation by depressing the test button. GFCI devices must be tested monthly or per manufacturers recommendations.
- D. This completes the installation of your Water Feature. If desired, the spray pattern can be adjusted or changed. Refer to the **“Adjusting/changing spray pattern”** section of this manual.



VI. Technical Specifications

Pattern	HP	Voltage	Phase	Motor RPM	Running AMP Draw	Spray Height*		Spray Diameter*	
LM10*	1/2	115	1 ph	3450 @ 60 Hz	12.0	12'		2'	
	1/2	230	1 ph	3450 @ 60 Hz	6.0	12'		2'	
	1/2	220	1 ph	2875 @ 50 Hz	3.9	2.9 m		0.6 m	
	3/4	230	1 ph	3450 @ 60 Hz	8.0	15'		2'	
LM11	1/2	115	1 ph	3450 @ 60 Hz	12.0	2.5'		12'	
	1/2	230	1 ph	3450 @ 60 Hz	6.0	2.5'		12'	
	1/2	220	1 ph	2875 @ 50 Hz	3.9	0.8 m		4.3 m	
	3/4	230	1 ph	3450 @ 60 Hz	8.0	3.0'		19'	
LM20*	1/2	115	1 ph	3450 @ 60 Hz	12.0	I/S	O/S	I/S	O/S
						8'	4'	2'	12'
	1/2	230	1 ph	3450 @ 60 Hz	6.0	8'	4'	2'	12'
						2.1 m	1.2 m	0.6 m	3.7 m
1/2	220	1 ph	2875 @ 50 Hz	3.9	3.9	2.1 m	1.2 m	0.6 m	3.7 m

*Spray patterns will vary by adjusting the diffuser ring. Therefore, the figures given are averages. Spray patterns will also vary due to voltage drop, humidity and other relevant site situations

Unit Weight: 45 lbs. (21Kg) and includes power center, unit, spray patterns and 50' (15.24 m) of underwater cable.

Minimum Operating Depth: is 18" (500 mm).

I/S = inner spray pattern

O/S = outer spray pattern

VII. Adjusting and Changing Spray Patterns

Your Water Feature can be configured into three different spray patterns. It has been factory assembled with the LM20 Series pattern. To change or adjust the pattern, refer to the proper section below and follow the directions carefully. Refer to the Exploded View Diagrams following each section for an illustration of referenced parts.

A. Adjusting the LM20 Series spray pattern. The outer spray pattern of the LM20 Series can be adjusted, using the supplied 1/8" Allen wrench, by repositioning the diffuser on top of the unit. Follow the steps below for adjustment.

1. Physically disconnect the power from the Water Feature.
2. Bring the Water Feature to shore and place the unit on a flat surface.
3. Using the supplied 1/8" Allen wrench, loosen the two setscrews holding the diffuser ring in position. Adjusting the ring up will lower the height of the outer pattern and increase its width. Lowering the ring will make the outer pattern higher and narrower. Adjust the ring to the new location and secure the two setscrews.



NOTE: Carefully, secure the setscrew. Applying excessive force will damage the ring or nozzle assembly. The top of the ring must not be adjusted above the top of the nozzle.

4. Place your unit back into the water, secure the mooring lines and re-apply power. If the pattern is not as desired, repeat above steps.

B. Changing to the LM20 Series spray pattern.

1. Physically disconnect the power from the Water Feature.
2. Bring the Water Feature to shore and place the unit on a flat surface.
3. Using the supplied 1/8" Allen wrench, loosen the two setscrews securing the diffuser ring in position and remove the diffuser ring.
4. Remove the four 1/4" bolts and the four screws on the top of the top retainer.
5. Carefully lift the top retainer off of the unit. A slight twisting motion may be required.

6. If the unit was configured as a LM10 Series, remove the LM10 Series nozzle from the unit.
7. Install the baffle into the top of the collector as illustrated below.

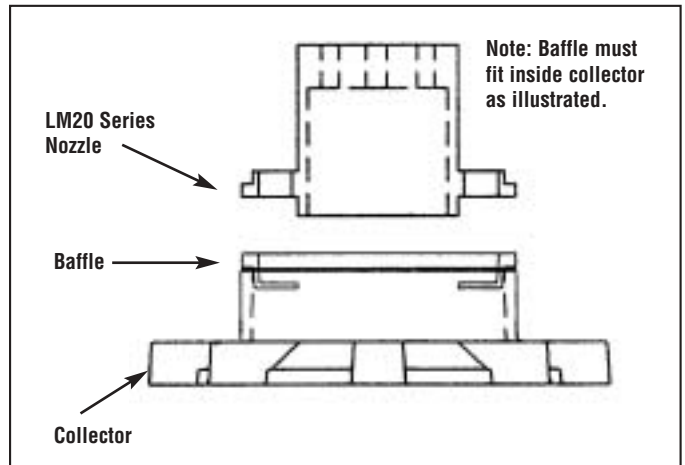

8. Place the LM20 Series nozzle (nozzle with 8 holes in center area) into the retainer.
9. Place the retainer back on the unit, secure the retainer to the collector using the four 1/4" bolts.

WARNING: Do not use excessive force. Damage to the pumping components may result.

Maximum torque is 20 in/lbs.

10. Reattach the retainer to the float using the four screws removed in step 4.
11. Reattach diffuser ring.

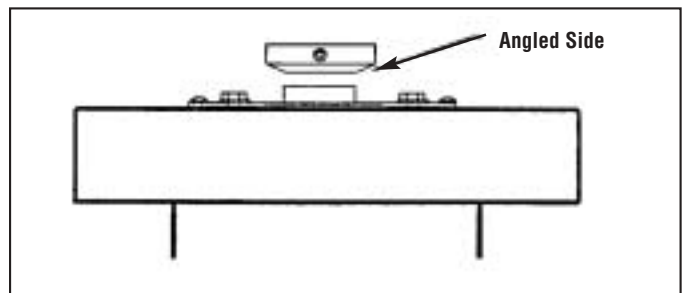

NOTE: Carefully, secure the setscrews. Applying excessive force will damage the ring or nozzle assembly. The top of the ring must not be adjusted above the top of the nozzle.

12. Place your unit back into the water, secure the mooring lines and reapply power. If the pattern is not as desired, refer to **“Adjusting LM20 Series Pattern Section.”**



Exploded View Diagram LM20 Series Pumping Configuration

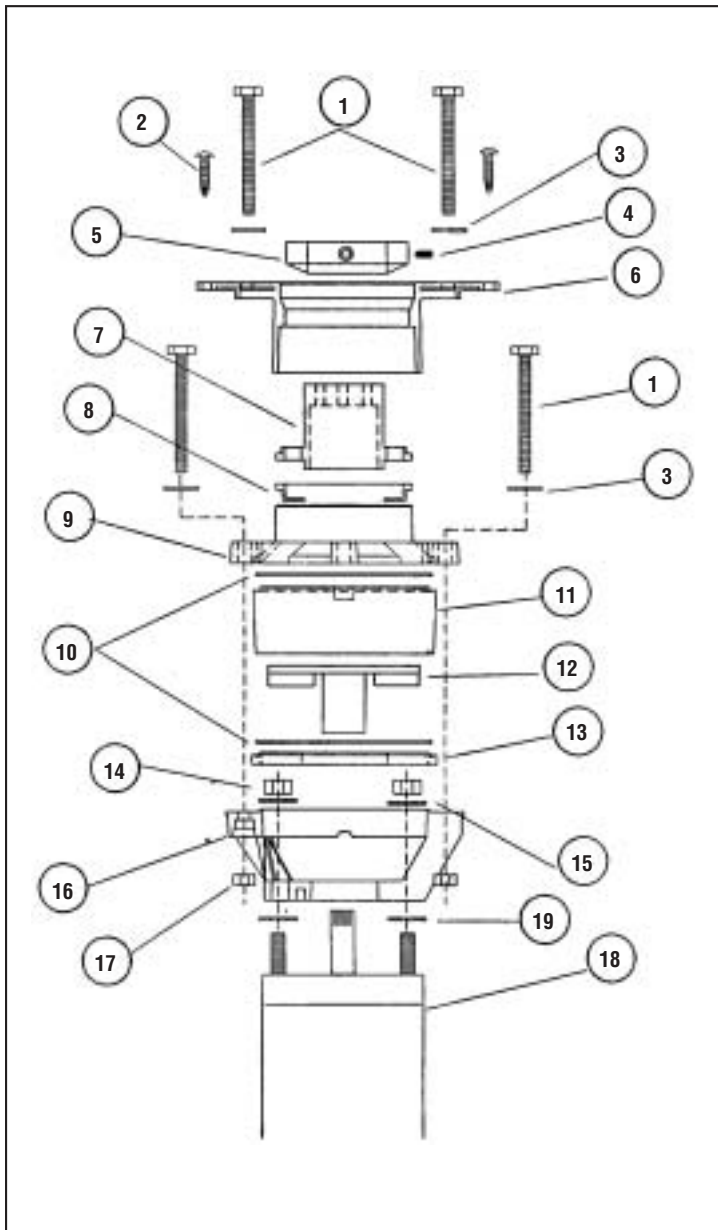

Item	P/N	Qty	Description
1	FR103	8	Hex Bolt - 1/4" - 20 x 2.75"
2	FR109	11	Self Tapping Screw - #10"
3	FR105	8	Flat Washer - 1/4"
4	FR108	2	Set Screw
5	FR804	1	Diffuser
6	FR209	1	Top Retainer
7	FR803	1	LM20 Series Nozzle
8	FR805	1	LM20 Series Baffle
9	FR207	1	Collector
10	FR701	2	O-Ring
11	FR206	1	Pump Chamber
12A	FR800	*	Impeller - 1/2 HP 60 Hz
12B	FR801	*	Impeller - 3/4 HP 60 Hz or 1/2 HP 50 Hz
13	FR205	1	Impeller Ring
14	FR102	1	Lock Nut - 5/16" - 24
15	FR104	1	Flat Washer - 5/16"
16	FR204	1	Standoff
17	C2-112	4	Lock Nut - 1/4" - 20
18A	FR601	*	Motor - 1/2 HP - 115V 60 Hz
18B	FR602	*	Motor - 1/2 HP - 230V 60 Hz
18C	FR603	*	Motor - 1/2 HP - 220V 50 Hz
18D	FR604	*	Motor - 3/4 HP - 230V 60 Hz
19	FR114	4	Heavy Washer - 5/16"

* One per unit depending on horsepower, voltage and frequency.

C. Adjusting the LM10 Series spray pattern.

The spray pattern of the LM10 Series can be adjusted, using the supplied 1/8" Allen wrench, by repositioning the diffuser on top of the unit. Follow the steps below:

1. Physically disconnect the power from the Water Feature.
2. Bring the Water Feature to shore and place the unit on a flat surface.
3. Using the supplied 1/8" Allen wrench, loosen the two setscrews holding the diffuser ring in position. Adjusting the ring up will increase the spray pattern width and slightly lower its height. Lowering the ring will make the pattern higher and narrower. Adjust the ring to the new location and secure the two setscrews.



NOTE: Carefully, secure the setscrews. Applying excessive force will damage the ring or nozzle assembly. The top of the ring must not be adjusted above the top of the nozzle.

4. Place your unit back into the water, secure the mooring lines and re-apply power. If the pattern is not as desired, repeat above steps.

D. Changing to the LM10 Series spray pattern.

1. Physically disconnect the power from the Water Feature.
2. Bring the Water Feature to shore and place the unit on a flat surface.
3. Using the supplied 1/8" Allen wrench, loosen the two setscrews securing the diffuser ring in position and remove the diffuser ring.
4. Remove the four 1/4" bolts and the four screws on the top of the top retainer.
5. Carefully lift the top retainer off of the unit. A slight twisting motion may be required.
6. If the unit was configured as a LM20 Series, remove the LM20 Series nozzle and baffle from the unit.

7. Place the LM10 Series nozzle (nozzle without holes in center area) into the retainer.

8. Place the retainer back on the unit, secure the retainer to the collector using the four 1/4" bolts.

WARNING: Do not use excessive force. Damage to the pumping components may result.

Maximum torque is 20 in/lbs.

9. Reattach the retainer to the float using the four screws removed in step 4.
10. Reattach diffuser ring.

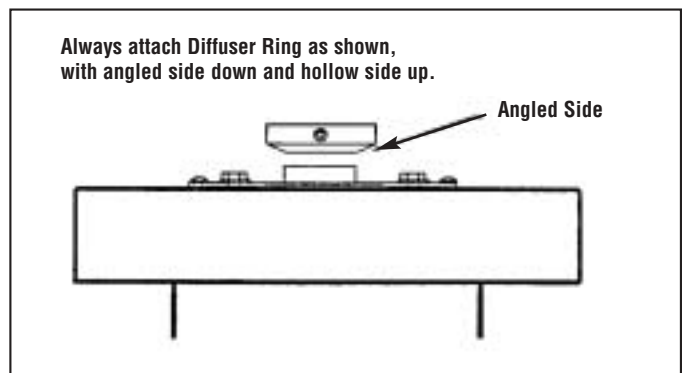

NOTE: Carefully, secure the setscrews. Applying excessive force will damage the ring or nozzle assembly. The top of the ring must not be adjusted above the top of the nozzle.

11. Place your unit back into the water, secure the mooring lines and re-apply power. If the pattern is not as desired, refer to **“Adjusting LM10 Series Pattern Section.”**



Exploded View Diagram LM10 Series Pumping Configuration

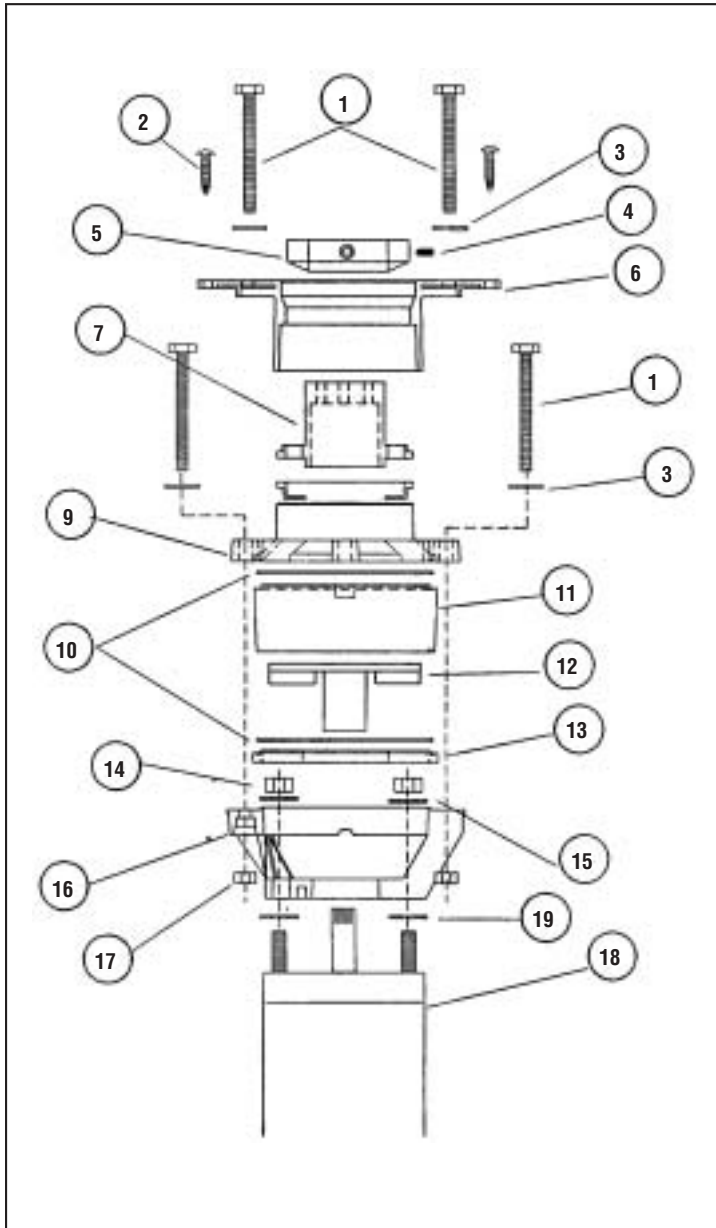

Item	P/N	Qty	Description
1	FR103	8	Hex Bolt - 1/4" - 20 x 2.75"
2	FR109	11	Self Tapping Screw - #10"
3	FR105	8	Flat Washer - 1/4"
4	FR108	2	Set Screw
5	FR804	1	Diffuser
6	FR209	1	Top Retainer
7	FR802	1	LM10 Series Nozzle
9	FR207	1	Collector
10	FR701	1	O-Ring
11	FR206	2	Pump Chamber
12A	FR800	*	Impeller - 1/2 HP 60 Hz
12B	FR801	*	Impeller - 3/4 HP 60 Hz or 1/2 HP 50 Hz
13	FR205	1	Impeller Ring
14	FR102	4	Lock Nut - 5/16" - 24
15	FR104	4	Flat Washer - 5/16"
16	FR204	1	Standoff
17	C2-112	4	Lock Nut - 1/4" - 20
18A	FR601	*	Motor - 1/2 HP - 115V 60 Hz
18B	FR602	*	Motor - 1/2 HP - 230V 60 Hz
18C	FR603	*	Motor - 1/2 HP - 220V 50 Hz
18D	FR604	*	Motor - 3/4 HP - 230V 60 Hz
19	FR114	4	Heavy Washer - 5/16"

* One per unit depending on horsepower, voltage and frequency.

E. Changing to the LM11 Series pattern.



NOTE: The shape of the LM11 Series pattern cannot be adjusted.

1. Physically disconnect the power from the Water Feature.
2. Bring the Water Feature to shore and place the unit on a flat surface.
3. Using the supplied 1/8" Allen wrench, loosen the two setscrews securing the diffuser ring in position and remove the diffuser ring.
4. Remove the four 1/4" bolts and the four screws on the top of the top retainer.
5. Carefully lift the top retainer off of the unit. A slight twisting motion may be required.
6. Remove the nozzle from the unit. If the unit was configured as a LM20 Series, also remove the LM20 Series baffle.
7. Place the retainer back on the unit, secure the retainer to the collector using the four 1/4" bolts.

WARNING: Do not use excessive force. Damage to the pumping components may result.

Maximum torque is 20 in/lbs.

8. Reattach the retainer to the float using the four screws removed in step 4.
9. Place your unit back into the water, secure the mooring lines and re-apply power. The LM11 Series pattern cannot be adjusted.



Exploded View Diagram LM11 Series Pumping Configuration

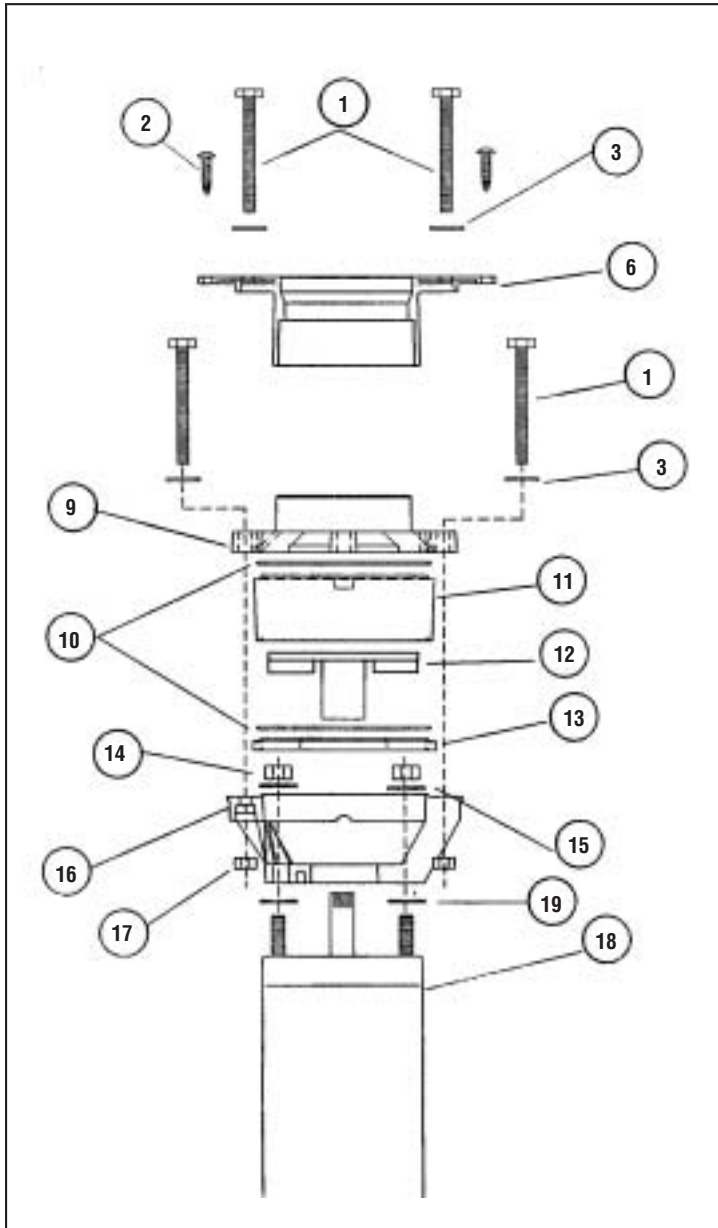

Item	P/N	Qty	Description
1	FR103	8	Hex Bolt - 1/4" - 20 x 2.75"
2	FR109	11	Self Tapping Screw - #10"
3	FR105	8	Flat Washer - 1/4"
6	FR209	1	Top Retainer
9	FR207	1	Collector
10	FR701	1	O-Ring
11	FR206	2	Pump Chamber
12A	FR800	1	Impeller - 1/2 HP 60 Hz
12B	FR801	*	Impeller - 3/4 HP 60 Hz or 1/2 HP 50 Hz
13	FR205	1	Impeller Ring
14	FR102	4	Lock Nut - 5/16" - 24
15	FR104	4	Flat Washer - 5/16"
16	FR204	1	Standoff
17	C2-112	4	Lock Nut - 1/4" - 20
18A	FR601	*	Motor - 1/2 HP - 115V 60 Hz
18B	FR602	*	Motor - 1/2 HP - 230V 60 Hz
18C	FR603	*	Motor - 1/2 HP - 220V 50 Hz
18D	FR604	*	Motor - 3/4 HP - 230V 60 Hz
19	FR114	4	Heavy Washer - 5/16"

* One per unit depending on horsepower, voltage and frequency.

Trouble Shooting Guide



SYMPTOM	POSSIBLE CAUSE	CORRECTION
Motor will not start	Breaker/fuse has tripped Low voltage Excessive cable length Defective or disconnected power cable GFCI device has tripped	Check breaker or fuse Reset/replace Verify voltage in specifications Verify acceptable maximum cable length Check and verify cable is properly connected Reset and test GFCI device Replace if necessary
GFCI device trips continuously	Defective power cable Bad or noisy power	Inspect cable for torn insulation Low voltage or surges may cause nuisance tripping
Unit turns on and off	Low voltage	Verify voltage is within specifications
Fuse blows or circuit breaker trips	Excessive cable length Defective motor	Verify acceptable maximum cable length Take a winding resistance reading 1/2 HP 115V 60 Hz = 1.0 - 1.3 ohms 1/2 HP 220V 50 Hz = 6.3 - 7.7 ohms 1/2 HP 230V 60 Hz = 4.2 - 5.2 ohms 3/4 HP 230V 60 Hz = 3.0 - 3.6 ohms
Spray pattern low or distorted	Clogged screen Clogged nozzle or pumping chamber LM20 Series pattern, baffle is missing LM11 Series or LM10 Series pattern, baffle is present Unit hitting bottom Diffuser ring installed wrong	Clean screen Clean nozzle or pumping chamber of debris Insert baffle in unit Remove baffle Move unit to deeper water Install diffuser ring with angled side down into unit
LM11 Series / LM20 Series Spray pattern is straight up, low and heavy	Missing diffuser ring	Attach diffuser ring
LM20 Series pattern no inner spray	LM10 Series nozzle installed	Install LM20 Series nozzle (8 holes in center of nozzle)
Spray pattern tilted	Cables not attached to bottom of unit	Attach cable using cable tie



IX. Maintenance

Your Rain Bird Water Feature has been designed for years of dependable service.

- The screen should be cleaned as required to prevent any intake restrictions.
- At least once a year, you should thoroughly inspect the water feature, underwater cable and mooring/anchor lines for any signs of external damage.

Winterization

If the temperature in your region of the country falls below 30°F (-1°C) for any extended period of time, Rain Bird strongly suggests that you remove your Water Feature from the water and store it in a dry and above freezing temperature location. Storage in a shed or garage where temperatures drop below freezing is not recommended as unit may freeze.

WARNING: This unit is not made to run in winter weather conditions. Leaving your Rain Bird Water Feature operating during the winter can lead to the Water Feature freezing in. If your Water Feature freezes in, motor or pumping component damage can occur. This will not be covered under warranty.

The motor used in this Water Feature is of a water lubricated design. Therefore, the unit must not be allowed to freeze as this will cause damage to the motor and pumping components. Unit must be stored in above freezing temperatures!

Exploded View Diagram - Unit

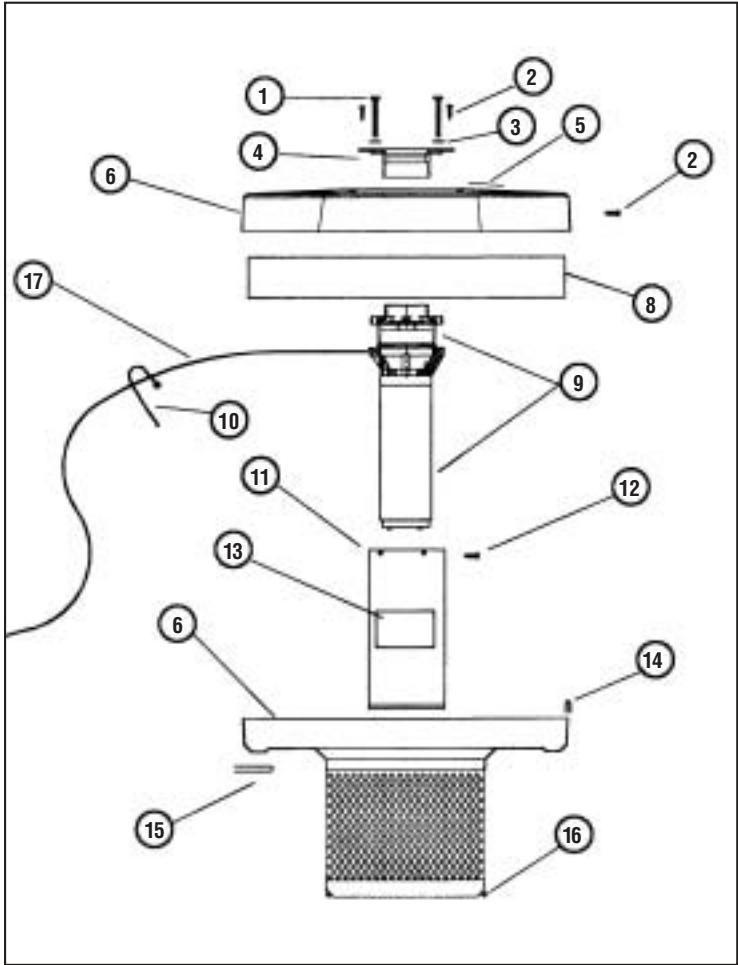

Item	P/N	Qty	Description
1	FR103	8	Hex Bolt - 1/4" - 20 x 2.75"
2	FR109	11	Self Tapping Screw - #10"
3	FR105	8	Flat Washer - 1/4"
4	FR209	1	Top Retainer
5	FR901	1	Warning Label
6	FR200	1	Shell/Screen assembly
8	42-0011	1	Float
9	80-0039	1	Pump Chamber
10	FR113	1	Cable Tie
11	FR301	1	Motor Sleeve
12	FR106	5	Self Tapping Screw - #8
13	C2-930	1	ID Label
14	FR101	11	Speed "U" Nut
15	FR302	2	Mooring Clip
16	FR112	2	Cable Tie Mount
17	FR500	1	Cord Assembly



X. 20W Low Voltage Lighting System- Specifications

This Lighting System uses 12 volt, 20W MR16 Type Bulbs, corrosion resistant thermoplastic light housings and stainless steel mounting brackets. The 20W Low Voltage Lighting System has a shore mounted transformer/timer. This limits the cable runs since the 12 volts is transformed at the shore. This system has a plastic wire junction to distribute power to each light. The controls consist of a transformer/timer module (controls are not supplied with 50 Hz systems).

Lights per set	2
Total Wattage*	40
Total Candlepower*	1400
Max Cable Run (ft)**	150

*12 Volt, 20 watt, 40 degree spread MR16 Type Bulbs (700 Candlepower each)

**This is for reference purposes only and may vary depending on actual voltage at the site.

XI. Electrical Installation - Standard Light Set (20W Bulbs)

- A. Plug the timer/transformer into a 115V waterproof outlet or connect it into the unit power control center. Connect the light power cable to the 12V output on the bottom of the timer transformer.
- B. After all electrical connections have been made, place the aerator/fixture in the water and apply power. Position cable to prevent any possible damage. If adjustment of any fixture is required, disconnect power and refer to the appropriate installation instructions and diagrams.
- C. Adjust the timer to operate the lights as desired (See inside lid of timer/transformer for timer operation instructions).

XII. Maintenance

Your light is designed for years of dependable service. Periodically clean the glass lens of any debris and check the cords for any damage.

XIII. Installation on an LMM Water Feature Unit

Wire Junction (Standard Lights)

- A. Secure (strain relief) the main power cord of the wire junction to the unit with the ty-raps provided as close to the plastic wire junction as possible. The plastic wire junction will be held in place when each light cord is secured with ty-raps.

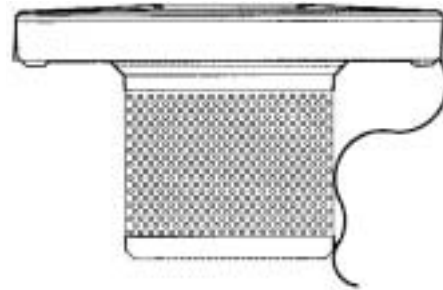

Strain relief the main power cord to the clip opposite the unit power cord to prevent the unit from tilting.

Light Fixtures

- A. Lights are mounted on the side of the float shell using one of the six screws securing the two float shell halves together. To mount the lights, remove two or three of the screws as shown. For two lights, it is recommended for them to be placed 180 degrees apart.
- B. Install the L-bracket as shown using the screws removed in Step A.
- C. The light brackets will already be mounted to the light fixtures at the factory. Install each light to each L-bracket using the 5/16" nut supplied.
- D. The light fixture can be tilted or rotated slightly for the best effect. Secure the light cords with the ty-raps provided.

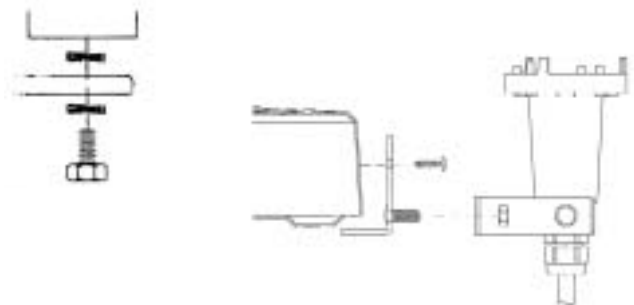

Item No	Description	Qty per Light	Part #
1	S/S Light Bracket	1	40-0105
2	1/4" -20 x 5/8 S/S Hex Bolt	1	24-0017
3	1/4" S/S External Star Washer	2	28-0013
4*	S/S "L" Light Bracket	1	FR704
5*	5/16" -18 S/S Nylon Locknut	1	GP1208
6*	Ty-Rap (not shown)	2	GP5008

* Light Mounting Hardware Kit, P/N 12-0086

XIV. Light Bulb Replacement

In the event that the light bulb requires replacement, follow these steps.

- A. Physically disconnect the power from the unit and the light set. Allow lights to cool to avoid skin burns.
 - B. Remove the light fixture(s) from the float and from the water. Dry excess water off of the light fixture.
 - C. Remove the light ring from the housing by twisting it counter-clockwise and lifting it off.
 - D. Remove the glass lens and o-ring.
 - E. Remove the bulb by pulling it straight out of the socket.
 - F. Install the new bulb by pushing it straight into the socket. Verify that the new bulb is the same wattage as the old bulb.
- NOTE:** The socket will be damaged if the bulb is not pulled out and pushed in straight. When installing or inspecting the bulb do not touch the inside of the reflector or the bulb itself with bare hands. This may cause premature failure or shorten bulb life.
- G. Reinstall the glass lens and the o-ring onto the top of the housing. Place the light ring on top of the housing so it rests in the tabs and twist it clockwise until it snaps into place.



NOTE: If the light ring is on the housing properly, there will be approximately a 1/8" gap to the right of each tab on the housing when looking from the top. If

this gap is not present, the light ring is not on properly and needs to be twisted more clockwise.

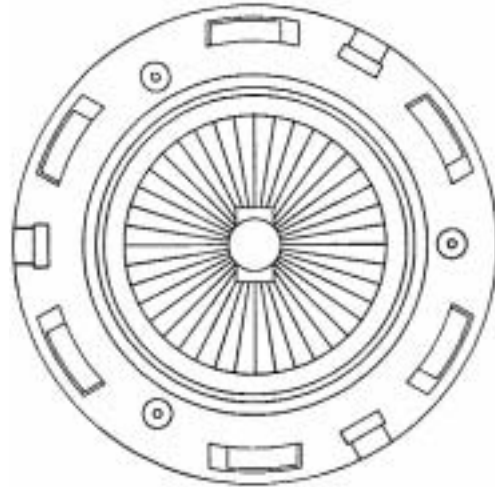

- H. Reinstall the light fixture(s) to the float.
- I. Reconnect power to the unit and the light set. Reset timers if necessary.

Warranty

Rain Bird® Lake Management Aerators are included in the Rain Bird Professional Customer Satisfaction Policy. For additional warranty information please contact your Rain Bird Distributor.