

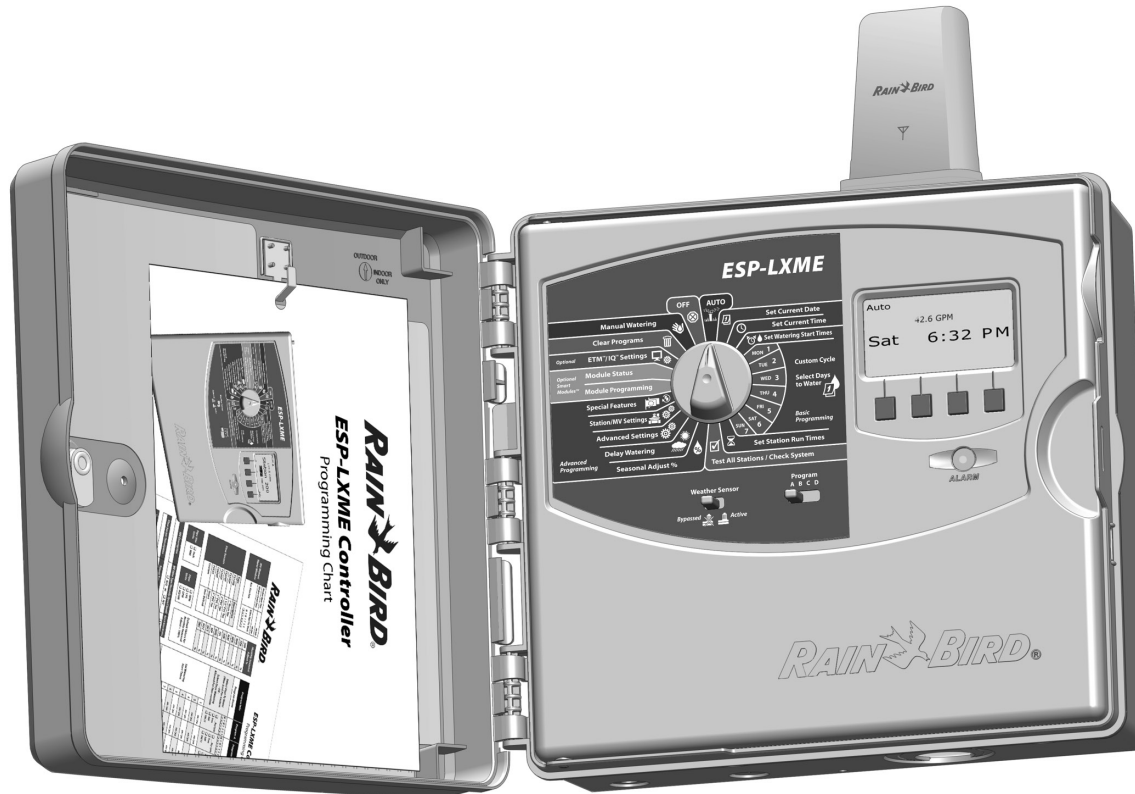







ESPLXME-ET Controller



Installation, Programming & Operation Guide



Symbols

-  **NOTE:** Symbol is intended to alert the user to important operating functionality, installation or maintenance instructions.
-  **WARNING:** Symbol alerts the user to the presence of electricity or electromagnetic energy which may constitute a risk of electric shock, radiation exposure or other hazard.
-  **CAUTION:** Symbol is intended to alert the user to important instructions or conditions that could seriously affect irrigation effectivity or controller operation.
-  **DIAL:** Symbol indicates that the user is required to turn the dial on the controller to the appropriate setting in order to follow subsequent instructions as described in that section.
-  **REPEAT:** Symbol indicates that a repetition of previous steps or actions may be required in order to continue or complete the controller programming process.

Safety Information

-  **WARNING:** A circuit breaker or cutoff switch must be provided in the fixed wiring to isolate the controller.
-  **WARNING:** The current date and time on the controller is retained by a long-life lithium battery, which must be disposed of in accordance with local regulations.



WARNING: You must use special precautions when valve wires (also known as station or solenoid wires) are located adjacent to or share a conduit with other wires, such as wires used for landscape lighting, other “low voltage” systems or other “high voltage” power. Be sure to separate and insulate all conductors carefully taking care not to damage wire insulation during installation. An electrical “short” (contact) between the valve wires and another source of power can damage the controller and create a fire hazard.



NOTE: This appliance is not intended for use by persons (including children) with reduced physical, sensory or mental capabilities, or lack of experience and knowledge, unless they have been given supervision or instruction concerning use of the appliance by a person responsible for their safety.

Children should be supervised to ensure that they do not play with the appliance.

For ESPLXME-ET technical assistance contact Rain Bird at 800 RAINBIRD (1-800-724-6247) U.S. and Canada or visit us on the web at www.rainbird.com

For ETC Manager Cartridge technical assistance contact the ET Manager Hotline at 1-877-351-6588 or visit us on the web at www.rainbird.com/etmanager

Contents

Section A - Introduction & Overview	1
Welcome to Rain Bird	1
ESPLXME-ET Controller.....	1
Controller Features.....	1
Controls, Switches and Indicators.....	2
Basic Operation.....	3
ET Manager Cartridge	4
Cartridge Features	4
Weather-Based Irrigation Control	4
WaterSense® Certification	5
Controls and Indicators.....	6
ESPLXME-ET Model	7
Base Modules	7
BM-LXME Base Module	7
ESPLXM-SM Station Modules	7
Programming Overview.....	9
Irrigation Controller Definitions.....	9
Programs	9
Watering Days	9
Watering Start Time	9
Station Run Time	9
Programming Chart	9
Fill Out Programming Chart	9
Storing the Programming Chart.....	10
Remote Programming	10
Programming Checklist	11
Set Up Hardware	11
Set Up Programs.....	11
Set Up Programs (Optional).....	11
Set Up ET Manager Cartridge	11
Review Setup	11
Optional Setup.....	11

AUTO.....	12
Automatic Operation	12
Alarm Conditions	13
FloWatch™ Alarms.....	13
Review Alarm Messages	13
Resetting the Controller	14
Resetting the ET Manager Cartridge	15
Section B - Basic Programming.....	17
Program Select Switch	17
Select Program	17
Weather Sensor Bypassed/Active Switch	17
Bypass or Activate Weather Sensor	17
Set Current Date	18
Set Current Time	19
Set Watering Start Times	20
Select Days to Water	21
Station Run Times.....	22
ET Manager Cartridge Configuration	23
Programming Overview	23
Programming Checklist	23
ET Manager Scheduler Software	24
ET Manager Resource CD.....	24
Installing the Software	24
Irrigation Site Assessment	24
Create a Schedule Report	25
EZ Setup Wizard	29
Complete Setup.....	30
Test Weather Signal.....	30
Setup a Local Rain Gauge	30
ESPLXME-ET Controller Settings.....	30

Section C - System Diagnostics 31

Test All Stations/Check System 31

Confirm Programs.....31
Program Summary31
Review Program.....32
Program Run Time35
Station Run Time36
Test All Stations37

Wiring Diagnostics 38

Raster Wiring Test38
Weather Sensor Status.....40
Master Valve Status41

ET Manager Alert Messages.....42

Landscape Condition Issues 45

Section D - Advanced Programming 49

Seasonal Adjust %.....49

Adjust Individual Program.....49
Adjust By Month.....50
Select Months to Adjust50
Select Programs To Adjust.....51

Delay Watering 52

Rain Delay52
Calendar Day Off53
Water Windows54
Station Delay55
Weather Sensor56
Local Weather Sensor Types56
Custom Pause Sensors56
Custom Prevent Sensors56
Weather Sensor Setup.....57

Advanced Settings 58

Watering Day Cycles58
Watering Cycle Definitions.....58
Custom, Odd, Odd no 31st, Even58
Cyclical Days.....59

Set Up SimulStations™61
Set SimulStations™ for Program.....61
Set SimulStations™ for Controller.....62
Station Sequencing.....63

Station/MV Settings 64

Station Settings.....64
Set Up Cycle+Soak™66
Module Status.....67
MV Settings68

ET Manager..... 70

Status Menu..... 71

Moisture Levels71
Weather Signal72
ET, Rain and Adj %.....74

Logs Menu 76

Irrigation Logs.....76
Interrupts78
Weather Information79

Settings Menu 80

Irrigation Control Menu80
Irrigation Amount.....80
Landscape Adjust82
Run Time Limits.....84
System Settings Menu86
Data Source Menu.....86
Weather Region.....86
Rain Source.....88
Signal Provider Code.....92
Control Settings Menu94
Effective Rain94
ET Settings Menu.....96
Options Menu 102
Set Historical ET 108
Weather Interrupts 110

Manual Watering 112

Backup and Recall Programs 112

Section E - Flow Management	113
Set Flow Units	113
FloManager™ Overview	114
FloManager™ Requirements	114
Set Up and Use FloManager™	114
Enable (Or Disable) FloManager™	114
Set FloManager™ Flow Rate	116
Set Station Flow Rates Manually	117
FloWatch™ Overview	118
FloWatch™ Configuration	118
Flow Sensor Hardware Installation.....	118
Flow Smart Module	118
Connect Flow Sensor	120
Module Programming	120
Setup Flow Sensor	120
SEEF and SELF Settings and Actions.....	122
Station Flow Rates	125
Learn Flow Automatically (All Stations)	125
Learn Flow Automatically (Custom Stations)	127
Set Station Flow Rates Manually	129
Clear Flow Rates	130
Enable (or Disable) FloWatch™	131
Module Status	132
View and Clear Flow Alarms.....	132
View Station Flow Alarms	132
View Mainline Flow Alarms	133
Clear Flow Alarms	134
View Flow Rates	135
View and Clear Flow Logs	136
View Current Flow.....	137
Section F - Options & Special Features	139
Set Language	139
Set Hours Mode	139
Backup and Recall Programs	140
Store Default Programs.....	140
Recall Default Programs.....	141
Delayed Recall	142

Section G - Auxiliary Operation.....	143
Clear Programs	143
Clear Individual Program.....	143
Clear All Programs.....	144
Restore Defaults.....	145
Manual Watering	146
Start Station Manually	146
Start Program Manually	147
MV Water Window.....	148
Set Up MV Water Window	148
Manually Opening a MV	150
Test All Stations	151
OFF.....	152
Adjust Display Contrast.....	152
Close the Master Valve.....	153
Section H - Installation	155
Prepare For Installation	155
Installation Checklist	155
Check Box Contents.....	156
Gather Installation Tools	157
Install the Controller	158
Select Location for Controller	158
Access Controller Cabinet.....	159
Remove Cabinet Door and Front Panel	159
Remove Modules	160
Mount the Receiver/Antenna.....	161
Mount Controller.....	162
Connect Power to the Controller.....	163
Surge Protection and Grounding.....	163
Connect Power Source.....	163
Re-install Front Panel.....	166
Install Modules	167
Install BM-LXME Base Module.....	167
Install Station Module.....	168
Dynamic Station Numbering	169

Connect Field Wiring	170
Connect Valve Wires	170
Connect Local Weather Sensor	172
Complete Controller Installation	173
Install Front Door	173
Verify Field Installation	173
Connect the ET Manager Cartridge	174
Overview	174
Connect Cartridge Cables.....	175
Rain Gauge Installation	177
Install the Local Rain Gauge	177
Connect the Local Rain Gauge.....	177
Appendix	179
Irrigation Amount and Station Run Times	179
Total Irrigation Amount.....	179
Station Run Time Settings.....	180
Program Station Run Times.....	180
Moisture Level Example	181
ET Manager Cartridge Default Settings	182
ET Manager Menu Tree.....	183
Test Cases.....	184
Rain Bird Support.....	186

Section A - Introduction & Overview

Welcome to Rain Bird

Thank you for purchasing your new state-of-the-art Rain Bird ESPLXME-ET controller.

For over seven decades Rain Bird has led the irrigation industry in meeting water management needs by providing the highest quality products and services available.

ESPLXME-ET Controller

Your new Rain Bird controller is designed to provide years of highly manageable irrigation control.

The ESPLXME-ET is an irrigation controller designed for commercial use. It accommodates up to 8 or 12 stations and through the addition of Station Modules can easily be expanded to address up to 48 total stations. The ESPLXME-ET uses weather data to automatically adjust irrigation schedules to reduce water consumption by watering only when the plants need it.

Controller Features

The ESPLXME-ET controller has a variety of advanced features to help you manage water efficiently, including:

- Flow, power, and station priority management
- Large variety of user-configurable irrigation program options to meet the most demanding irrigation needs while still addressing municipal mandates and restrictions
- Upgrade features including Station Modules and IQ Central Control
- Supports one local weather sensor input
- Outdoor-rated plastic cabinet which can be upgraded to the optional metal cabinet (LXMM) and pedestal (LXMMPED)
- UL, CUL, CE and C-TICK certified

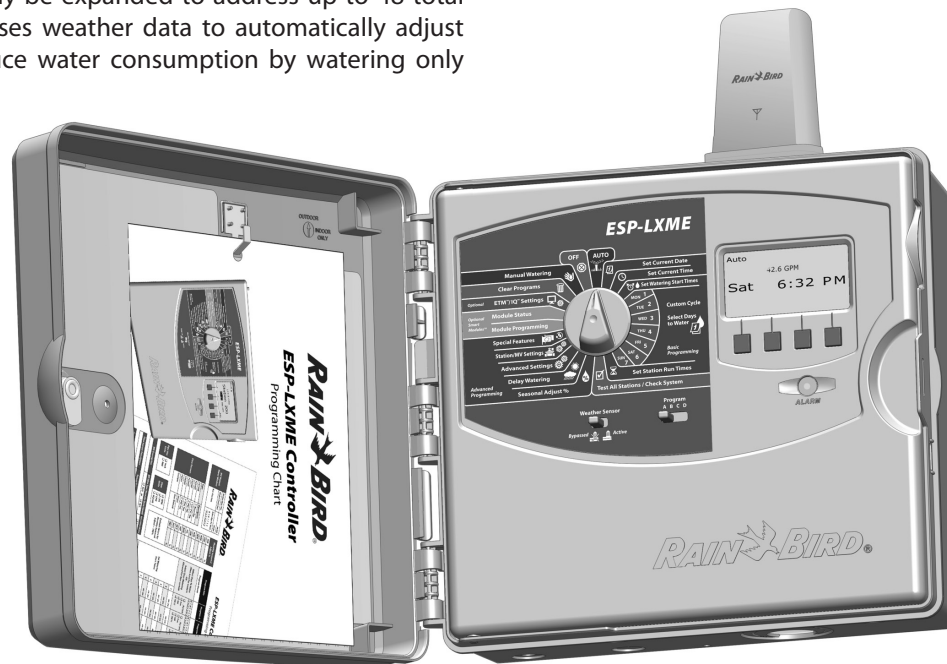

Controls, Switches and Indicators

Key operational features of the ESPLXME-ET Controller front panel:

1 Programming Dial

Used for programming and to turn the controller on and off.

2 Weather Sensor Switch

Set the controller to obey or ignore input from an optional sensor. See Section B, Weather Sensor Bypassed/Active Switch for more details.

3 Program Select Switch

Select Watering Program A, B, C, or D. See Section B, Program Select Switch for more details.

4 Display

Displays time of day during normal operation; shows commands during programming; shows active station and remaining run time during watering.

5 Programming Buttons

Press buttons to enter and change program information.

- Press and HOLD buttons to accelerate settings for hours, minutes and seconds, dates or percentages.

6 Alarm Light

Illuminates to indicate various types of alarm conditions. See Alarm Conditions for more details on how to review and clear alarms.

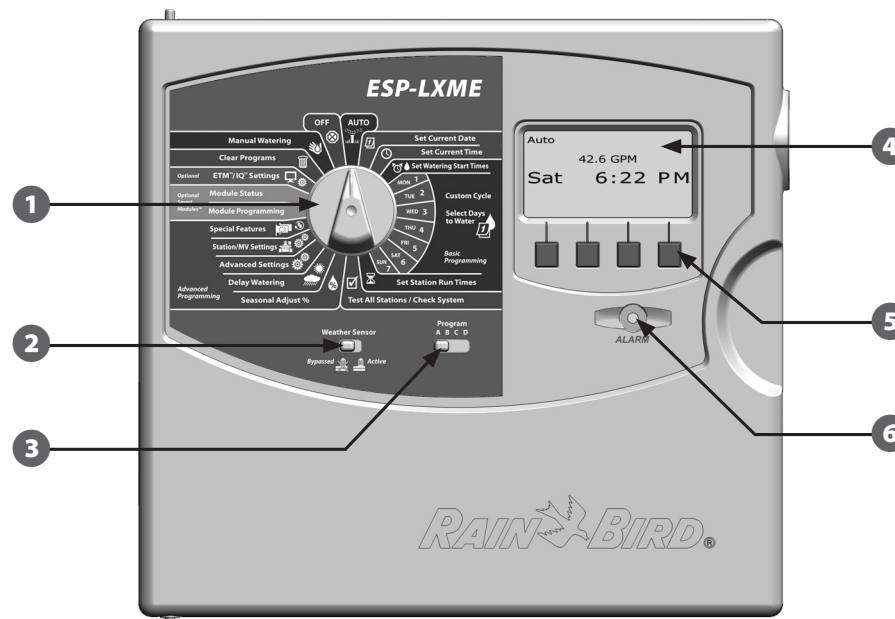

ESPLXME-ET Controller Front Panel Features

Basic Operation

Valves (or stations) operate at times as specified by irrigation programs.

The controller sends power to the first valve solenoid to open. When finished, the controller signals the solenoid to shut off its valve and then signals the second valve solenoid to open. Then when the second valve is finished, the third valve will begin watering and so on.

! **NOTE:** The ESPLXME-ET's SimulStations feature allows you to operate multiple stations at the same time. See section D for more details.

! **NOTE:** The ESPLXME-ET's Cycle+Soak feature may delay valve operation. See Section D, Set Up Cycle+Soak for more details.

The ESPLXME-ET lets you set a delay between stations. For example, if you set a one minute delay, station 1 will run until finished, followed by a one minute delay. Then station 2 will run, followed by another one minute delay, and so on. See Section D, Station Delay for more details.

The order in which stations are selected to operate depends on the following settings:

- Station Sequencing settings
- Station flow rate (FloManager)
- Station priorities
- POC flow rate (FloManager)
- Station run times
- SimulStation settings
- Station program assignment

! **NOTE:** When using Station Sequencing by priorities, set station priorities higher for stations you want selected earlier in a program and lower for stations you want selected later in a program.

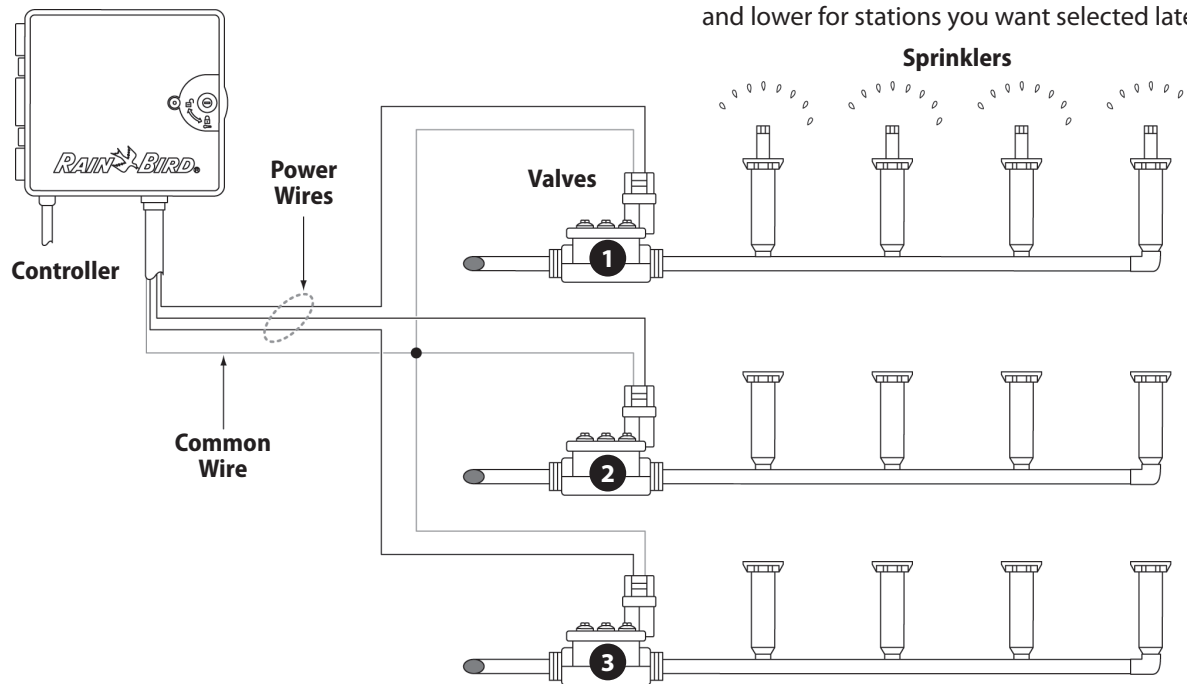

LXME System Wiring Diagram

ET Manager Cartridge

The ET Manager Cartridge provides weather-based irrigation control.

Real time weather information is used to automatically adjust watering run times to meet the needs of the landscape, which significantly reduces overwatering.

Cartridge Features

Key features of the ET Manager Cartridge include:

- Water savings of 20–50% over traditional time-based irrigation control.
- Seasonal Adjust percentages are automatically adjusted according to current weather conditions to efficiently manage water use.
- Weather Interrupts based on current rainfall, temperature, and wind speed automatically cancel watering during adverse weather conditions.
- Irrigation Logs provide total amount of water applied, number of days watered, current weather information, and Weather Interrupt history.

Weather-Based Irrigation Control

Watering requirements are automatically adjusted according to landscape needs based on weather and site conditions.

The ET Manager Cartridge is programmed to receive hourly weather information from a local Weather Reach™ Signal Provider (WRSP) and uses this information along with site-specific settings to determine when and how much water your landscape needs.

! **NOTE:** To find your local Weather Reach™ Signal Provider, you can create a site-specific Schedule Report using the ET Manager Scheduler software found on the ET Manager Resource CD (included) or visit www.rainbird.com/wrsp.

The ET Manager Cartridge manages watering by changing the Seasonal Adjust percentage value that is set in the ESPLXME-ET Controller. This increases or decreases the programmed watering run times for each station. When watering is not needed, the Seasonal Adjust percentage will be set to 0% to conserve water. When watering is needed, the Seasonal Adjust percentage will increase to meet watering needs. A minimum and maximum limit can be set by the user.

The ET Manager uses measured ET values to determine watering needs. Evapotranspiration (ET) is a measurement of water that evaporates from the soil and transpires from the plant. ET represents moisture loss from the root zone.

Weather parameters used to measure evapotranspiration (ET) include:

- Solar Radiation
- Wind
- Temperature
- Humidity

Local rainfall amounts are received from the weather signal or measured by an on-site rain gauge (the ET Manager Cartridge accepts input from both 1mm/tip and 0.01"/tip rain gauges).

The Rain Bird Local Rain Gauge (ETM-RG) is the recommended on-site Rain Gauge for use with the ET Manager Cartridge.

WaterSense® Certification

The ESPLXD-ET Controller is certified by the EPA as a product that conserves water.

WaterSense is a partnership program sponsored by the U.S. Environmental Protection Agency (EPA) that labels products proven to conserve water.

All WaterSense labeled products are independently certified to meet the EPA's water efficiency and performance criteria. The criteria for irrigation controllers is based on the industry's Smart Water Application Technologies™ guidelines for weather-based controllers.

The presence of a WaterSense label identifies the Rain Bird ESPLXD-ET Controller as a product proven to conserve water, save money and help save the environment.



Controls and Indicators

Key operational features of the ET Manager Cartridge:

1 Cartridge Power Indicator

LED indicates power status.

2 Communications Indicator

LED indicates communication status between cartridge and controller.

NOTE: Light Emitting Diode (LED) lights appear on the right side of the ET Manager Cartridge. LEDs provide continuous status updates and illuminate according to the following table.

Color	Indication	Activity
None	(dark)	No Power
Upper light Red	Blinking	Power is present – communication between ESPLXD-ET Controller and ET Manager Cartridge is absent.
Lower light Red	Blinking	Power is present – communication between the controller and ET Manager Cartridge is absent.
Upper light Green	Solid	Power and communications are OK.
Lower light Green	Solid	Power and communications are OK.
Both lights Green	Blinking	A Rain Gauge input was detected.
Both lights Yellow	Blinking	Call Rain Bird Technical Support
Both lights Amber	Blinking	No connection between cartridge and controller.
Both lights Amber	Solid	Failed to communicate.

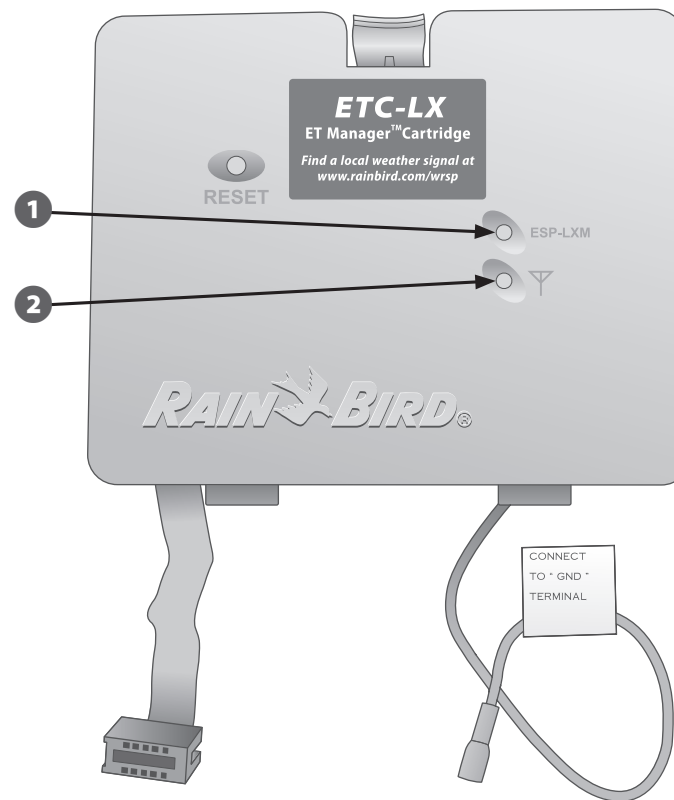

ET Manager Cartridge Features

6 ESPLXME-ET Controller

ESPLXME-ET Model

Rain Bird offers one model of the ESPLXME-ET controller:

Model	Modules Included
ESPLXME-ET	BM-LXME Base Module ESP-LXM-SM12 Station Module

Base Modules

Base Modules install in module slot 0 and provide wiring terminals for multiple controller inputs and outputs including valve common, master valve, weather sensor, and 24 VAC.

BM-LXME Base Module

The BM-LXME Base Module is the standard base module for ESPLXME-ET Controller models.



ESPLXM-SM Station Modules

ESPLXM-SM Station Modules install in module slots 1 through 4 and provide wiring terminals for irrigation valves and a valve common.

Each ESPLXME-ET controller comes standard with a 12 station module. This can easily be expanded by adding one to three additional Station Expansion Modules. Each station module adds 4, 8, or 12 additional stations to increase capacity to a maximum of 48 stations. Station Modules can be identified by the blue stripe on the middle of the module.



ESP-LXM-SM8 Station Module



ESP-LXM-SM12 Station Module

this page intentionally left blank

Programming Overview

Irrigation Controller Definitions

Programs

The process of telling the controller exactly when and for how long you want to water. The controller opens and closes the remote control valves according to a program you set.

Each program contains:

Watering Days

The days of the week or calendar dates on which irrigation is allowed. For example, specific days such as Monday, Wednesday and Friday could be designated as your “watering days”. Alternatively, the Cyclical watering cycle can be used to water at a regular interval, such as every third day.

Watering Start Time

The time(s) of day that irrigation begins; this is the time that the first station in the program begins watering; all other stations in the program then follow in sequence.

NOTE: The term “start time” refers to the time that a program starts, not to the time that each individual station begins to run.

Station Run Time

The length of time (in hours and minutes) that each individual station is programmed to run.

Programming Chart

Before you begin programming, fill out the Programming Chart. See the Programming Chart instructions for more details.

- 1 Locate the Programming Chart that came with the ESPLXME-ET controller.



Fill Out Programming Chart

- 2 Follow the instructions to enter information about your system hardware and settings in the appropriate fields on the Programming Chart.

Station #	Description	No. of Valves	Station Flow Rate	Requires MV	Weather Sensing
1	ENTRY - SPRAYS	1	52	<input checked="" type="checkbox"/>	<input checked="" type="checkbox"/>
2	ENTRY - COLOR BEDS	2	26	<input type="checkbox"/>	<input type="checkbox"/>

An arrow points from a circled '2' to the 'Requires MV' checkbox for station 2.

Storing the Programming Chart

Return the Programming Chart to a permanent, safe location when you're finished working with it. We recommend hanging it on the hook inside the controller cabinet door as shown below.

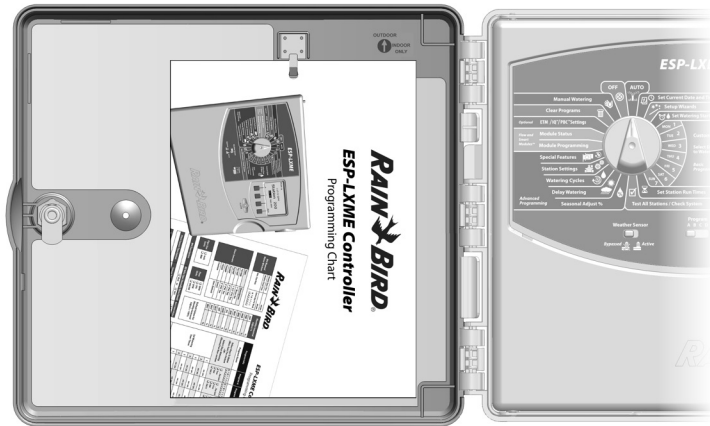

Remote Programming

The ESPLXME-ET controller front panel can be programmed while operating under battery power.

This feature is useful if the controller is installed in an area that is not easily accessible. It also lets you enter program information before installing the controller at the job site. All program information is stored in nonvolatile memory so it will be preserved indefinitely in the event of a power outage or removal of the battery.

NOTE: Under battery power, all programs in progress will continue to run in the controller memory, but irrigation will not occur until power is restored. Without battery power, programs in progress are cancelled.

- 1 Install a new 9-volt battery in the battery compartment in the back of the front panel.

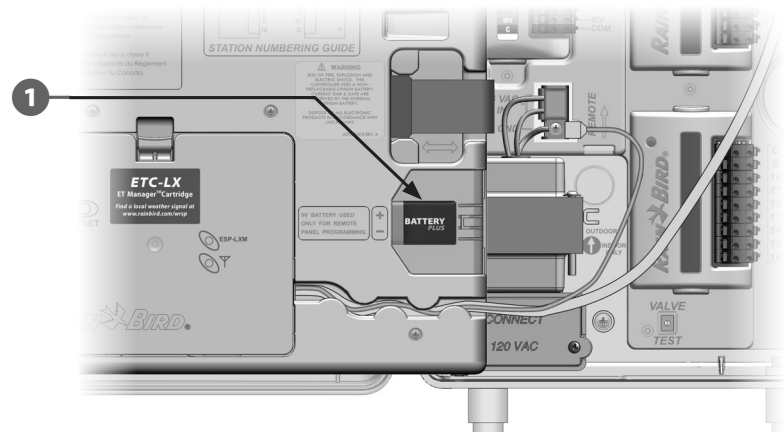

NOTE: To perform remote programming under battery power, detach the front panel from the cabinet. See Access Controller Cabinet in Section H for more details.

CAUTION: The controller can not run irrigation or system diagnostics with the front panel detached. Re-connect the front panel to the controller's AC power source as soon as remote programming is completed.

Programming Checklist

When programming the ESPLXME-ET controller for the first time, it is recommended that you complete the following steps in order.

For your convenience a check-off box is provided for each step.

Set Up Hardware

- Install SM Station Modules Page 168
- Install ET Manager Antenna Page 161
- Install ET Manager Cartridge Page 174
- Fill out Programming Chart (see Programming Chart instructions)
- Clear program information..... Page 143
- Set language..... Page 139
- Set date..... Page 18
- Set time..... Page 19
- Set up master valve (optional)..... Page 68
- Set up weather sensor (optional) Page 57
- Set up stations Page 64
- Set up flow sensor with Flow Smart Module (optional) Page 120

Set Up Programs

A B C D

- Select program (A, B, C or D)..... Page 17
- Set watering start times Page 20
- Select watering days * Page 21
- Set station run time(s)..... Page 22

* See Advanced Settings dial position for Odd, Odd31, Even and Cyclical watering cycles.

Set Up Programs (Optional)

- Set seasonal adjust..... Page 49
- Create a water window Page 54
- Set up a station delay Page 55
- Set up SimulStations..... Page 61

Set Up ET Manager Cartridge

- Create Schedule Report..... Page 25
- Run EZ Setup Wizard..... Page 29
- Test Weather Signal Page 30

Review Setup

- Confirm program Page 31
- Test stations Page 37
- Check installed modules Page 132

Optional Setup

- Schedule calendar days off Page 53
- Create an MV manual water window..... Page 148
- Set Cycle+Soak..... Page 66
- Set flow units..... Page 113
- Activate FloManager..... Page 114
- Activate FloWatch..... Page 131
- Set up SEEF and SELF actions Page 122
- Set controller to AUTO Page 12

AUTO

Automatic Operation

The controller will operate automatically with the controller dial set to AUTO.

If you forget to return the dial to AUTO, the controller will automatically continue to run programs, unless the dial is set to the OFF position when all irrigation is canceled.

- ▶ Turn the controller dial to AUTO.

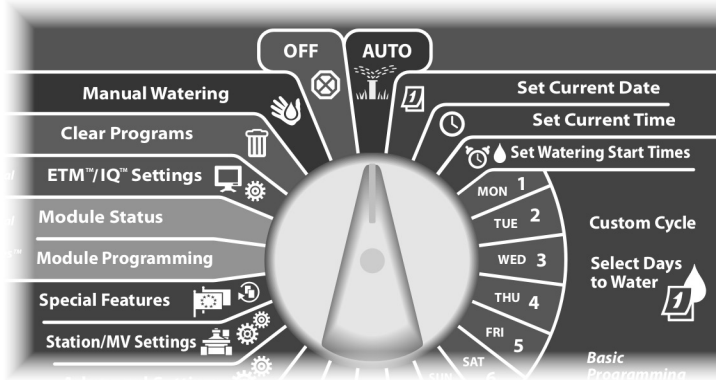

- 1 The Auto screen is displayed with the current day and time shown.
- 2 When a program is running in AUTO mode, the station number will display on the screen. Press the + or – buttons to add or subtract minutes from the run time for the currently running station. To advance to the next station in a program, press the Adv button.

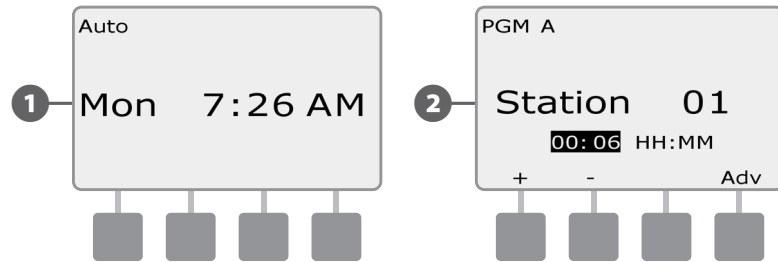

- ▶ To cancel a currently running program, turn the controller dial to OFF for three seconds and then return the dial to AUTO.

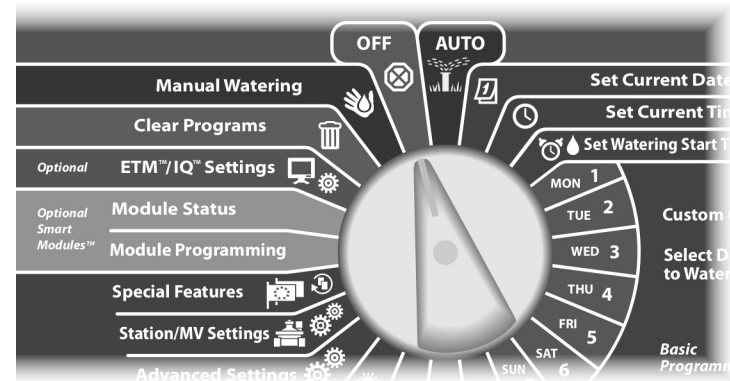

Alarm Conditions

An alarm condition can occur when programming omissions or other issues prevent normal irrigation.

FloWatch™ Alarms

The controller will alarm for certain flow conditions if you have the optional Flow Smart Module installed. See Section E, FloWatch for more details.

Review Alarm Messages

- 1 When an alarm condition is detected, the alarm light on the controller front panel will illuminate.

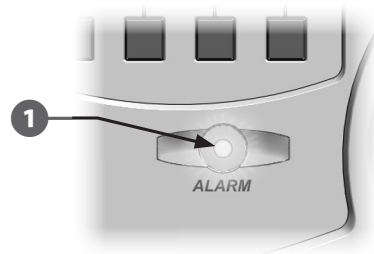

- 2 Turn the controller dial to AUTO.

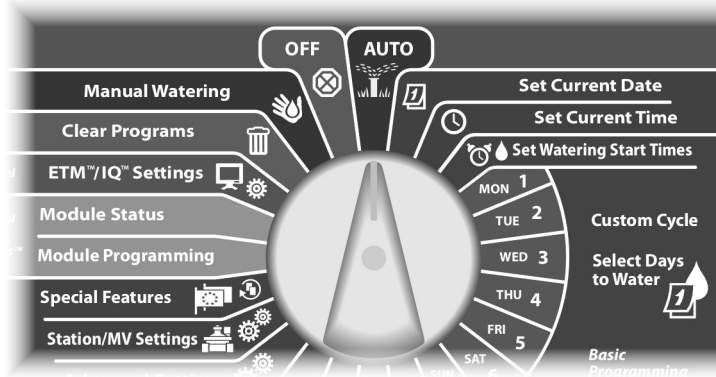

- 2 When an alarm condition is present, the Alarm button label will be present on screen. Press the Alarm button to view alarm details.
- 3 Any current alarm conditions will then be displayed. Press the Next button if necessary, to advance to the next page.

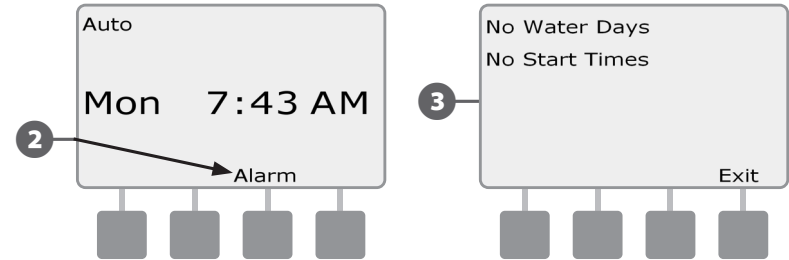

- NOTE:** Take the appropriate action to address each alarm condition. When all alarms have been addressed, the alarm light on the front panel will no longer be illuminated.

Resetting the Controller

Sometimes you may want to reset (or reboot) the ESPLXME-ET controller. Using the controller's reset feature does not change or delete the programs you have programmed into the controller.

- Turn the controller dial to AUTO.

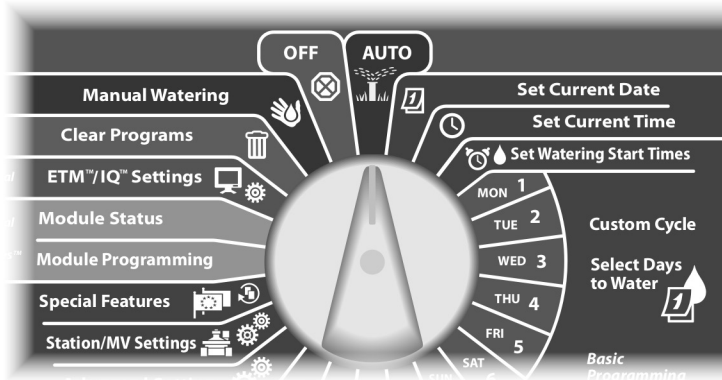

- Open the controller outer cabinet door and inner front panel.
- Locate the RESET button on the back of the front panel.

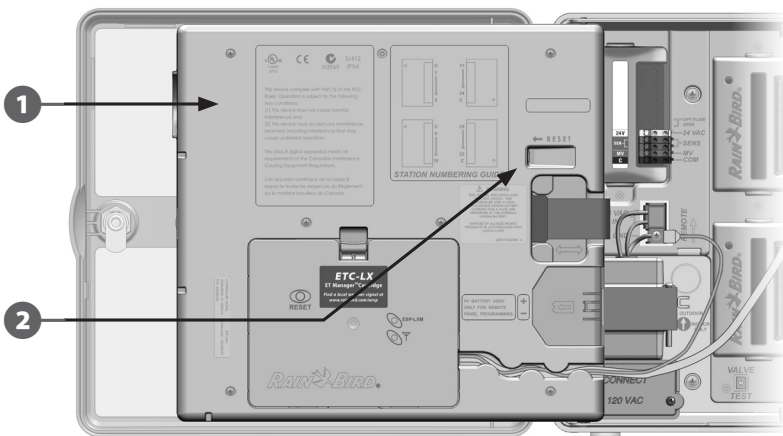

- Use a pen or pencil to depress the RESET button.
- The "Rain Bird" screen appears, confirming reset.

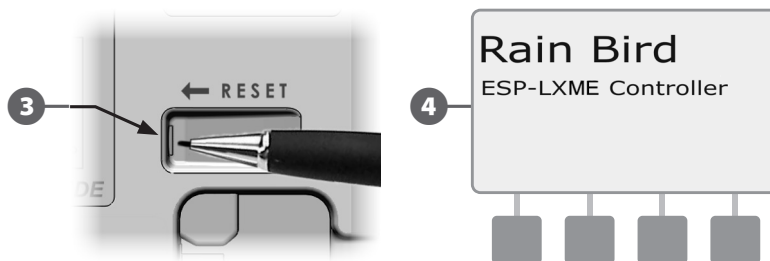

14 ESPLXME-ET Controller

Resetting the ET Manager Cartridge

A Reset button is provided on the face of the ET Manager Cartridge. The purpose of this control button is to restart the cartridge's internal programming and re-enable communications with the ET Manager Receiver.

! **NOTE:** Resetting the ET Manager Cartridge does not affect internally stored data such as event logs, WRSP signal provider codes or other settings.

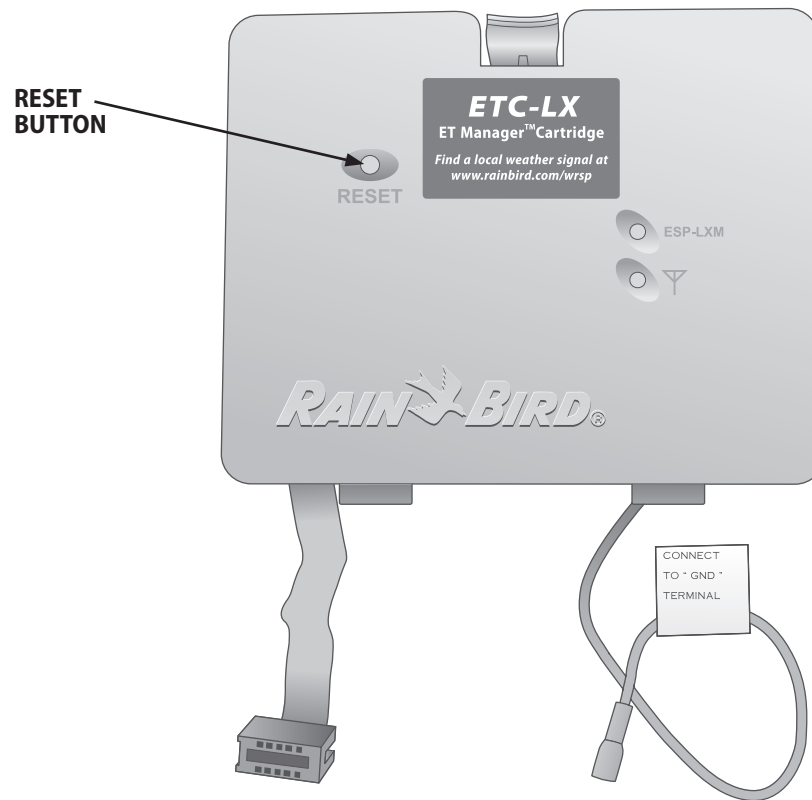

this page intentionally left blank

Section B - Basic Programming

Program Select Switch

Always begin programming by setting the Program Select switch to the desired program.

Four independent Programs, A, B, C and D are available in the ESPLXME-ET controller. Multiple programs allow you to set watering schedules to meet different requirements for plant materials, soils, slopes, and shady or sunny areas. Programs can operate simultaneously with the only limitation being the number of stations you program to run simultaneously.

Select Program

On the controller front panel, slide the Program Select switch under the A, B, C, or D, then begin programming.

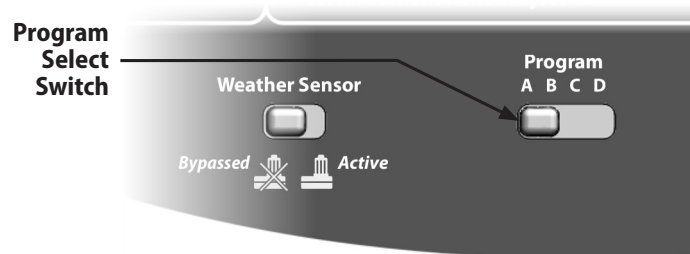

! **NOTE:** When programming the controller, any program-specific information you enter, such as start times or watering days, will affect only the selected program.

Weather Sensor Bypassed/Active Switch

A weather sensor is not required for the ESPLXME-ET controller, but can increase functionality by allowing you to prevent or pause irrigation based on changing weather conditions.

You can set the controller to ignore or obey input from one supported weather sensor, which connects to the LXME base module via a separate wired or wireless connection. See Section H, Local Weather Sensor for more details.

Bypass or Activate Weather Sensor

On the controller front panel, slide the Weather Sensor switch to Bypassed (to ignore) or Active (to obey).

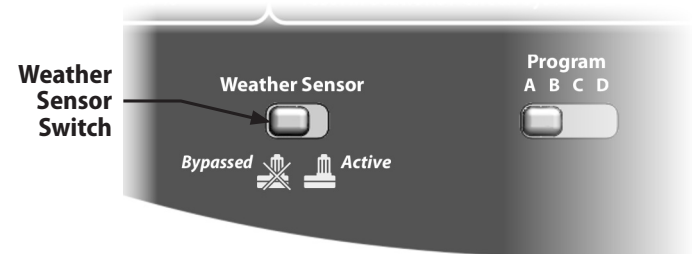

Set Current Date

- Turn the controller dial to Set Current Date.

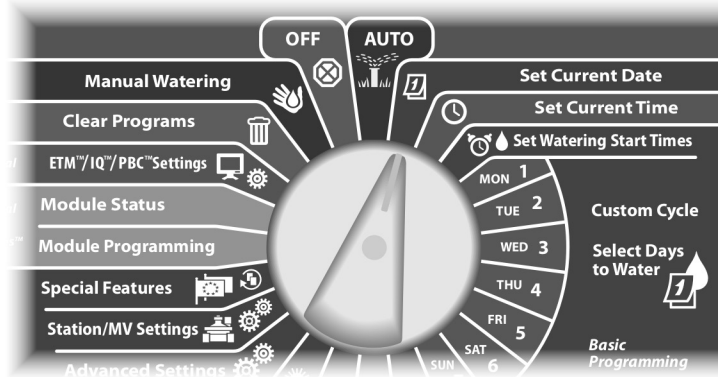

- The Set Current Date screen appears. Press the + and – buttons to set the current day; then press Next.
- Press the + and – buttons to set the current month; then press Next.

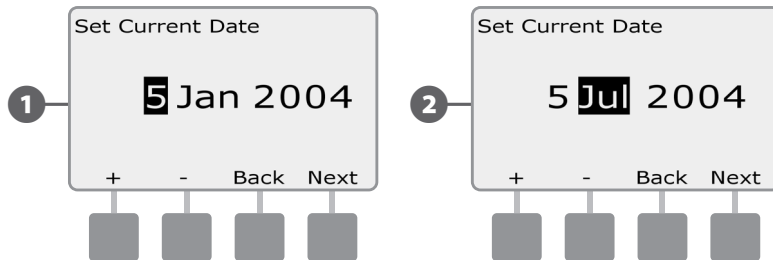

- Press + and – to set the current year.

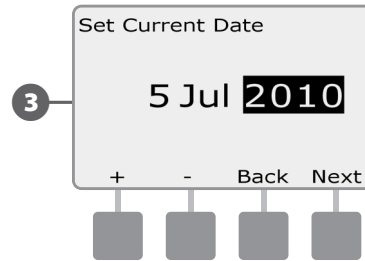

Set Current Time

- Turn the controller dial to Set Current Time.

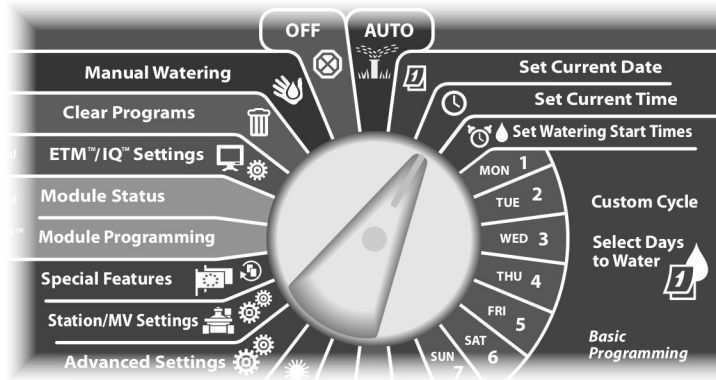

- The Set Current Time screen appears. Press the + and – buttons to set the current hour; then press Next.

- NOTE:** Be sure to set the hour correctly to either AM or PM.
 - Press and HOLD buttons to accelerate settings for hours and minutes.

- Press the + and – buttons to set the current minute; then press Next.

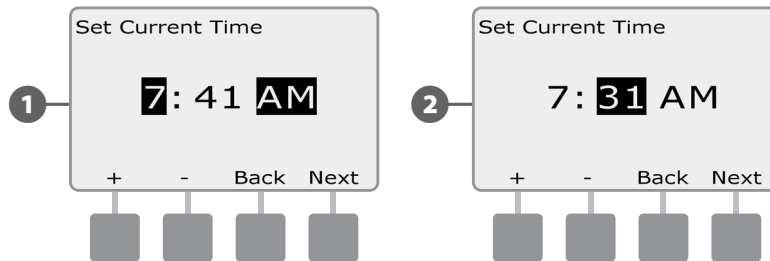

Set Watering Start Times

Start times are the time(s) of day that the program begins.

You can assign up to eight Start Times per day to a single program. Multiple Start Times allow you to run a program more than once on each day. For example, if you're growing new lawn seed, you may want to water several times a day to keep the seedbed or top dressing damp.

! **NOTE:** Start times apply to the entire program and not just to an individual station.

! **NOTE:** Enter Start Times that your landscape would need during the hottest, driest part of the year. The ET Manager will change the Seasonal Adjust percentages depending on the weather conditions.

▶ Turn the controller dial to Set Watering Start Times.

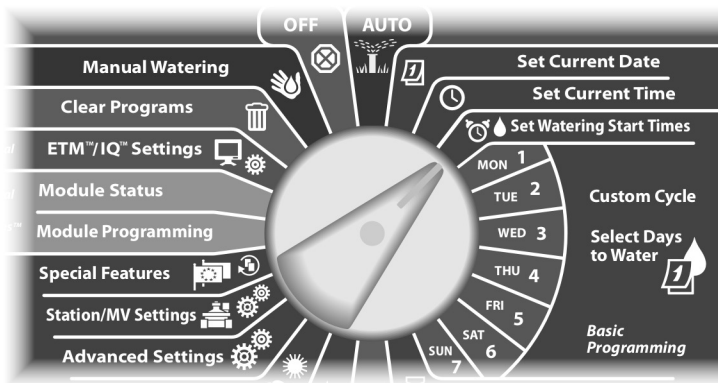

1 The Set Start Times screen appears. Press the + and – buttons on the left to set Start Time for the current program.

- Press and HOLD buttons to accelerate settings for hours and minutes.

! **NOTE:** If the desired program is not selected, use the Program Select switch to change it. See Section B, Program Select Switch for more details.

2 Press the + and – buttons on the right to set the start number (1 through 8).

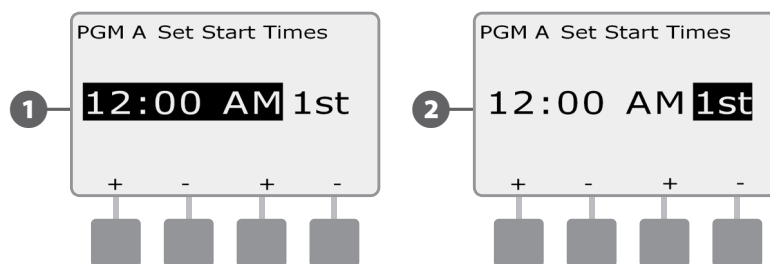

↻ Change the Program Select switch and repeat this process to set up additional Watering Start Times for other programs as desired.

! **NOTE:** Cycle+Soak™ is an alternative method of dividing the total Station Run Time into smaller cycle times. If you plan to use Cycle+Soak, only a single Watering Start Time is required for each program. See Section D, Set Up Cycle+Soak for more details.

Select Days to Water

Watering Days are the specific days of the week on which irrigation programs are allowed to start.

The ESPLXME-ET controller can be programmed to irrigate on different days, dates and cycles. Regardless of which Watering Cycle you set, the controller will only start the program on the days or dates that you select. For additional information see Watering Cycles later in this section.

NOTE: The selections you make on the day positions of the controller dial will carry over to the Watering Cycles day settings and vice versa.

NOTE: Every day should be selected as a watering day if possible. The ET Manager will change the Seasonal Adjust percentages depending on the weather conditions.

Turn the controller dial to Mon 1.

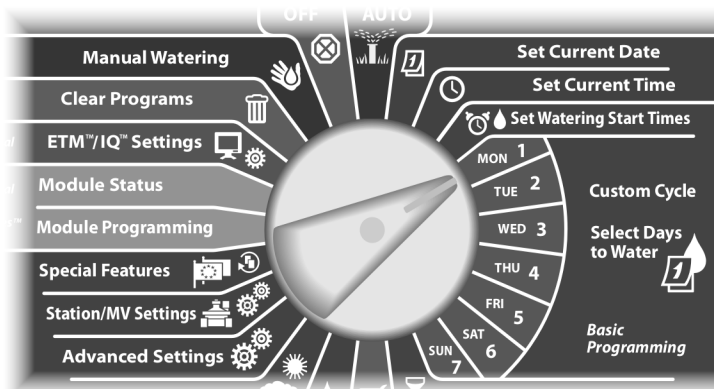

1 The Custom screen appears. Press the Allow or Prevent buttons to choose whether or not to allow irrigation starts to occur for that day of the week.

NOTE: If the desired program is not selected, use the Program Select switch to change it. See Section B, Program Select Switch for more details.

2 Turn the controller dial to Tue 2 and repeat the process.

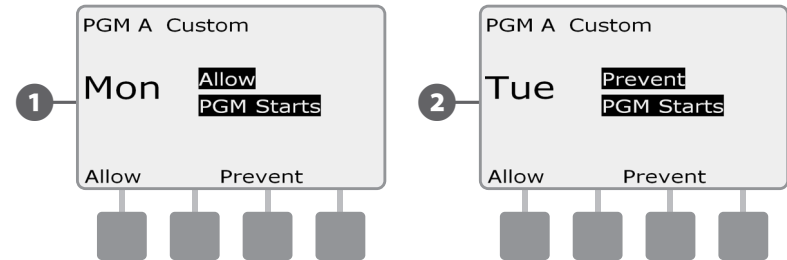

Repeat this process for all other days of the week in the program. Then change the Program Select switch and repeat this process to select Days to Water for other programs as desired.

Station Run Times

Run Times are the number of minutes (or hours and minutes) that each station runs.

Station Run Times are particular to programs; so typically stations are set for a single program.

NOTE: Enter Run Times that your landscape would need during the hottest, driest part of the year. The ET Manager will change the Seasonal Adjust percentages to increase or decrease watering run times depending on the weather conditions.

Turn the controller dial to Set Station Run Times.

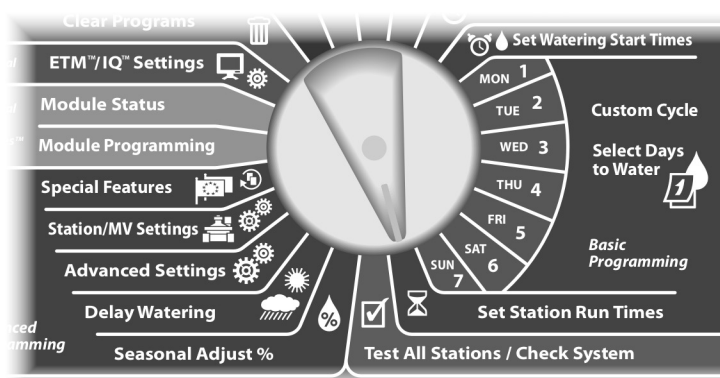

1 The Set Run Times screen appears. Press the + and – buttons on the left to select the station to program.

NOTE: If the desired program is not selected, use the Program Select switch to change it. See Section B, Program Select Switch for more details.

2 Press the + and – buttons on the right to set the Station Run Time. Range can be from 00 minutes (no Run Time) up to 24:00 hours.

- Press and HOLD buttons to accelerate settings for hours and minutes.



Change the Program Select switch and repeat this process to set up additional Station Run Times for other programs as desired.

ET Manager Cartridge Configuration

Programming Overview

After installation, the ET Manager Cartridge must be configured to receive weather data from a local weather station, and a watering schedule based on actual site conditions needs to be determined.

- A detailed Site Assessment is recommended to gather information (such as sprinkler types, soil types and root depth) about the site that will help determine the watering schedule.
- The Rain Bird ET Manager Scheduler software program uses the capabilities of your sprinkler system and actual site conditions to help prepare a watering schedule and determine ET Manager Cartridge and ESPLXME-ET controller settings.
- After using the ET Manager Scheduler Software, use the Schedule Report Summary generated from your inputs to help complete the EZ Setup Wizard.
- Programming, configuration, and operation of the ET Manager Cartridge is ALL accomplished from the same dial position on the LX Controller - ETM™ / IQ™ Settings or ETM™ / IQ™ /PBC™ Settings.

If you are NOT using the ET Manager Scheduler Software, you will need to have the information listed below prior to programming the cartridge. This information is available on the Weather Reach™ Signal Provider Information Sheet found online at www.rainbird.com/wrsp or through your distributor.

Inputs from the Weather Reach™ Signal Provider Information Sheet:

- Signal Provider Code
- Weather Region number
- Approximate Elevation
- Average Daily Historical ET values for each Month (used as backup data)

Irrigation Amounts per Program:

- Irrigation Amount (in inches or mm) for each program

The Irrigation Amount setting is the amount of water applied by the irrigation system per program start time. If necessary, Irrigation Amounts can be manually calculated. See the Irrigation Amount and Station Run Times section in the Appendix for more details.

ET Manager Programming Software

The Rain Bird® ET Manager Programming Software (ETMPS) is an optional program (available for purchase) that uses your personal computer to simplify ET Manager programming. This application allows the user to transfer ET Manager Scheduler settings directly from the PC to an ET Manager Cartridge via a USB cable.

Refer to the ET Manager Programming Software Operation Guide located on the Resource CD for more information.

Programming Checklist

When programming the ETC Manager Cartridge for the first time, it is recommended that you complete the following steps in order.

For your convenience a check-off box is provided for each step:

- Conduct Site Assessment..... Page 24
- Install Scheduler Software..... Page 24
- Create Schedule Report..... Page 25
- Run EZ Setup Wizard..... Page 29
- Test Weather Signal Page 30
- Set up Rain Gauge (optional)..... Page 30
- Check ESPLXME-ET Controller Settings Page 30
- Set Controller to Auto

Irrigation Site Assessment

A detailed site assessment will help the ET Manager Scheduler software determine an effective watering schedule. Use the ET Manager Site Assessment Worksheet located on the Resource CD to help complete the site assessment.

Factors to consider while assessing the irrigation site:

- Is my irrigation system designed so that each valve has only one general plant type assigned to it? What is that plant type?
- Are all my rotors/sprays achieving head to head coverage? What level of distribution and efficiency am I achieving at the site?
- What sprinkler types am I using? Rotors? Sprays? Drip?
- What type(s) of soil are present on the property? If more than one type, where is each located in relation to the hydro-zones?
- Is the plant life mature or young? How deep are the roots for each plant type?
- What, if any, areas are on a slope?
- Is my landscape generally healthy?

Answers to the preceding questions and information gathered from completing the Site Assessment Worksheet will help guide you through the ET Manager Scheduling Software.

! **NOTE:** The ET Manager Cartridge will not automatically compensate for irrigation design errors or faulty sprinkler equipment.

ET Manager Scheduler Software

ET Manager Resource CD

Included in the purchase of your ET Manager Cartridge is a FREE Resource CD. This CD includes the ET Manager Scheduler Software, Tutorials, Worksheets, Application Information, Designer Resources, and more.

It is highly recommended to use the ET Manager Scheduler Software before starting any programming of your ET Manager Cartridge.

Installing the Software

- 1 Insert the ET Manager Resource CD into the CD / DVD drive on your computer.
- 2 Double-click the ETMiCD.exe file.
- 3 Select the "Install ET Manager Scheduler" option to install the Scheduling Software.



Create a Schedule Report

The ET Manager Scheduler Operation Guide, which is located on the Resource CD or available in the Help menu, contains detailed and helpful instructions on creating a Schedule Report and should be used as a reference when creating a Schedule Report. Use the information from your Site Assessment Worksheet to fill in the Schedule Report tabs.

- 1 From the ET Manager Scheduler home screen, select “New Schedule ETC-LX”.



- 2 The Site tab appears. Complete every field, then click “Next” in the bottom right corner.
- ! **NOTE:** As each tab is completed, a new tab is created at the top of the page for future reference.
- ↻ **REPEAT** Step 2 for each new tab until all tabs are complete.

The screenshot displays the 'ET Manager Scheduler' application window. The 'Site' tab is active, showing a form with the following sections:

- Site Information:** Includes a text field for 'Site Name', a date dropdown menu set to '5/7/2012', and a large text area for 'Notes'.
- Prepared By:** Includes text fields for 'Company', 'Contact', 'Address', 'Phones', and 'Email / Web'.
- Prepared For:** Includes text fields for 'Company', 'Contact', 'Address', 'Phones', and 'Email / Web'.
- Sprinkler Controller:** Includes a dropdown menu for 'Controller' (currently set to 'Rain Bird - ESPLXD200') and a text field for 'Controller Location'.

At the bottom of the window, there are buttons for 'Close', 'Back', and 'Next'. A circled '2' is positioned to the left of the 'Site Information' section.

- Once you have completed all the tabs, a summary tab will be created. Save the Schedule Report to your computer. You can create a different schedule for as many irrigation sites as you need, and retrieve any file in the future to add or update the schedule.

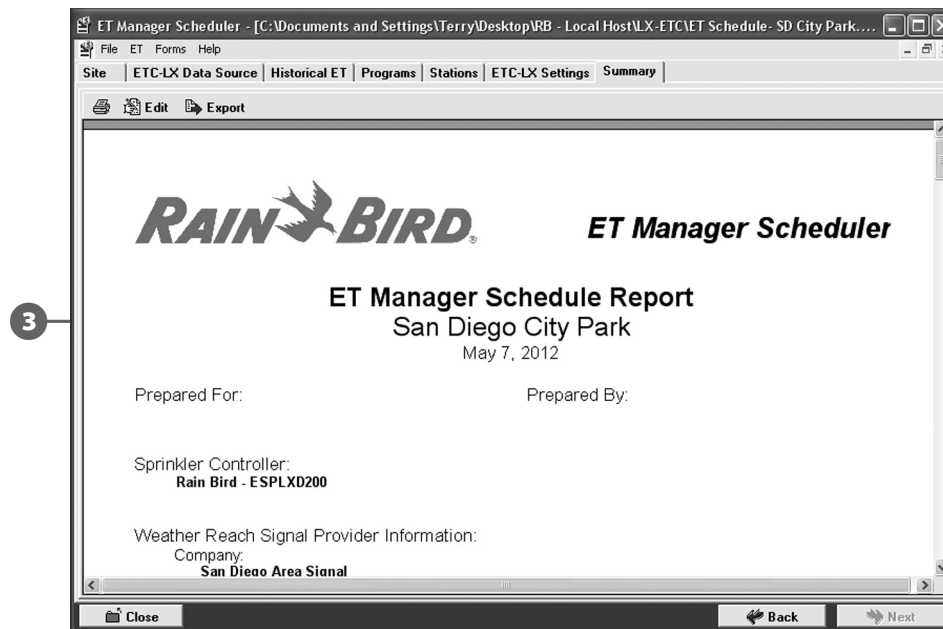

4 Print and refer to the Schedule Report to program the ET Manager Cartridge using the EZ Setup Wizard.

! **NOTE:** If you have purchased the ET Manager Programming Software, the summary from the Scheduler Software can be sent directly to the ET Manager Cartridge through your computer. Refer to the ET Manager Programming Software Operation Guide located on the Resource CD for more information.

RAIN BIRD *ET Manager Scheduler*

ET Manager Schedule Report
San Diego City Park
May 7, 2012

Prepared For: Prepared By:

Sprinkler Controller:
Rain Bird - ESPLXD200

4 Weather Reach Signal Provider Information:
Company:
San Diego Area Signal

1-877-351-6588
<http://www.rainbird.com/etmanager/>

Weather Station:
San Diego
Region:30
Keamy Mesa
San Diego, CA

The San Diego Area Signal is provided as a public service to improve water management. This signal is funded by Weather Reach Signal Sponsors.

RAIN BIRD *ET Manager Settings*

Watering schedule prepared using the Rain Bird ET Manager Scheduler. For more information on Rain Bird's water management products visit our web site at: www.rainbird.com

EZ Setup Wizard

It is highly recommended to use the ET Scheduler Software to create a Schedule Report before programming your ET Manager Cartridge.

The Schedule Report contains all the Signal Provider Code, Weather Region, Elevation, Average Daily Historical ET values, and Irrigation Amount Per Program Start Time values you will need to use the EZ Setup Wizard.

NOTE: If you are NOT using the ET Manager Scheduler Software, this information is available on the Weather Reach™ Signal Provider Information Sheet found online at www.rainbird.com/wrsp or through your distributor.

To use the EZ Setup Wizard follow these steps:

Turn the controller dial to ETM™/IQ™ (or ETM™/IQ™/PBC™) Settings.

NOTE: If the EZ Setup Wizard is NOT displayed, press the EZ button from the Moisture Levels screen.

- 1 The EZ Setup Wizard appears. Press **Next**.
- 2 The Signal Provider Code screen appears. Press the **+ and -** buttons to enter the value for A. Press **Next** to move to the next letter. When the value for every letter is entered, press **Next**.

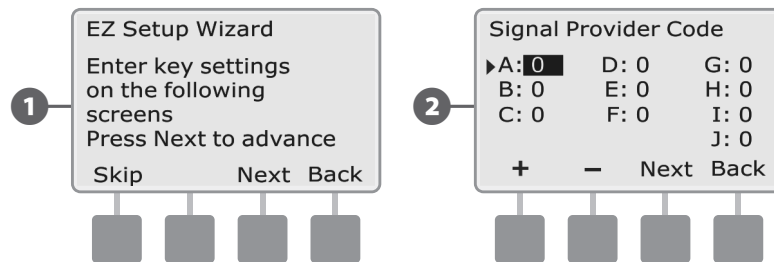

- 3 The Weather Region screen appears. Press the **+ and -** buttons to enter the Weather Region number; then press **Next**.
- 4 The Units screen appears. Press the **+ and -** buttons to select English or Metric; then press **Next**.

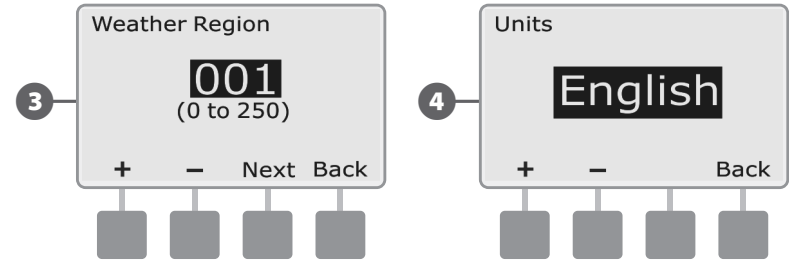

- 5 The Elevation screen appears. Press the **+ and -** buttons to enter the elevation for the irrigation site; then press **Next**.
- 6 The Average Daily Historical ET screen appears. Press the **+ and -** buttons to enter the daily Historical ET average for January. Press **Next** to move to the next month. When the ET average for every month is entered, press **Next**.

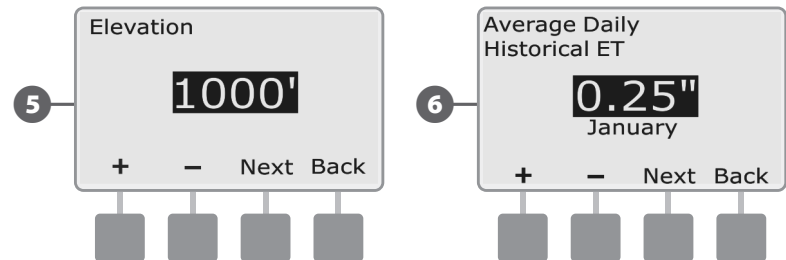

NOTE: Historical ET data will be used if the "ET Source" is set to "Historical", in the event of a power outage, or as backup to paging signal interference. The ET Manager CAN be used with historical data only – instead of receiving data from a weather station.

7 The Irrigation Amount Per Program Start Time screen appears. Press the **+** and **-** buttons to enter the Irrigation Amount for Program A. Press **Next** to move to the next program. When the Irrigation Amount for every program is entered, press **Done**.

! **NOTE:** To manually calculate Irrigation Amounts, see the Irrigation Amount and Station Run Times section in the Appendix.

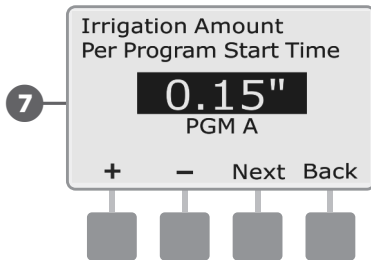

! **NOTE:** Programs which you do NOT want watered based on evapotranspiration (such as landscape lighting or a fountain feature) must be set to "Non ET". This is set by pressing the - button until 0.00 is displayed, then pressing the - button one more time to display "Non ET".

Complete Setup

Test Weather Signal

To verify that your ET Manager Cartridge is ready to receive weather data, check the signal and activation status by following the steps in the Weather Signal section.

Setup a Local Rain Gauge

If you have installed the Local Rain Gauge (ETM-RG), you must set the ET Manager Cartridge Rain Source to "ETM-RG" by following the steps in the Rain Source section.

ESPLXME-ET Controller Settings

After the ET Manager Cartridge is setup, the current program settings in the ESPLXME-ET Controller should be updated or verified based on the Schedule Report and the following guidelines.

ESPLXME-ET Controller programming guidelines:

- Irrigate EVERYDAY of the week if possible.
- Enter start and run times that your landscape would need during the hottest, driest part of the year.
- Set Seasonal Adjust to 100%.

Remember, the ET Manager will change the Seasonal Adjust percentages to increase or decrease watering run times depending on the weather conditions.

! **NOTE:** It is important to keep all run times for a valve on one Program. For example, do not turn on Valve 1 in both Programs A and B.

Section C - System Diagnostics

Test All Stations/Check System

Review and confirm scheduled irrigation Programs, Program Run Times and Station Run Times.

Confirm Programs

The ESPLXME-ET controller can make calculations and provide feedback on Start Times and total Run Times for programs and stations.

Program Summary

Review program information for all programs:

- Turn the controller dial to Test All Stations/Check System.

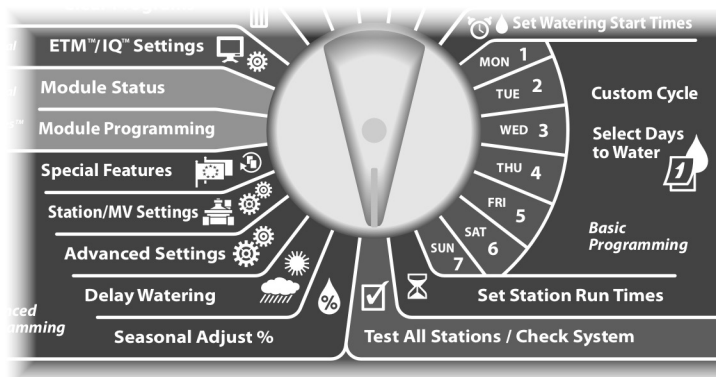

- The Check System screen appears with Confirm Programs selected; press Next.
- The Confirm Programs screen appears with Program Summary selected; press Next.

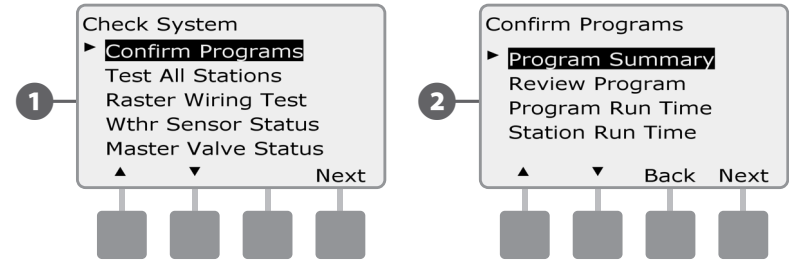

- The Program Summary screen appears, providing a summary of Run Times, Start Times and Water Days for all programs.

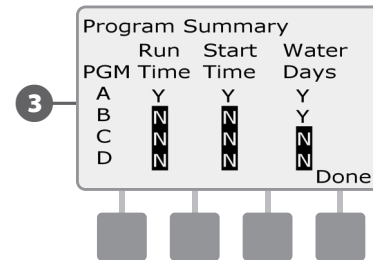

- NOTE:** In the above example, Program A will run because it has Station Run Times, Start Times and Water Days all programmed, as indicated by the "Y" in each column for PGM A.

Program B however will not run as it is missing both the Run Time and Start Time, as indicated by the "N" in each of those columns for PGM B.

Review Program

Review program information for a station:

- Turn the controller dial to Test All Stations/Check System.

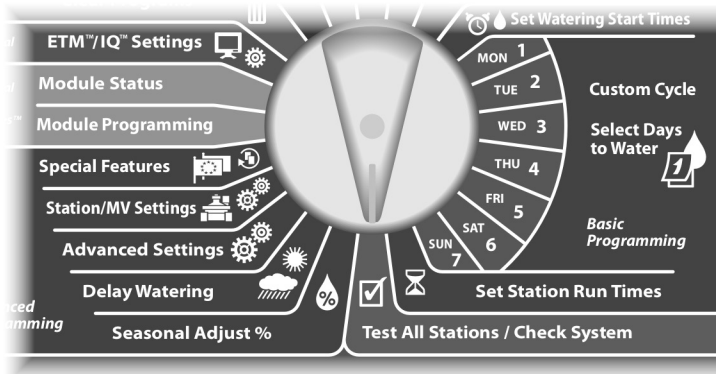

- The Check System screen appears with Confirm Programs selected; press Next.
- The Confirm Programs screen appears. Press the Down Arrow button to select Review Program; then press Next.

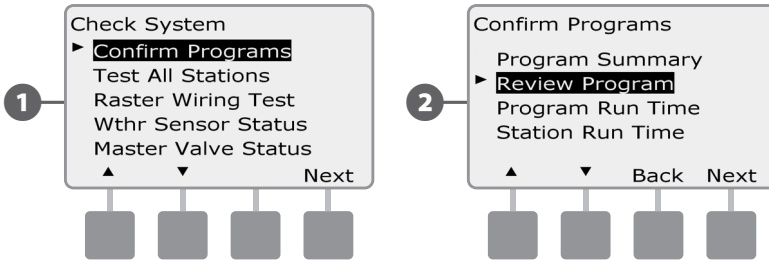

- The Watering Start Times review screen appears with start times displayed for the currently selected program. Press Next.

NOTE: If the desired program is not selected, use the Program Select switch to change it. See Section B, Program Select Switch for more details.

- The Watering Day Cycle review screen appears with the current watering day cycle displayed. Press Next.

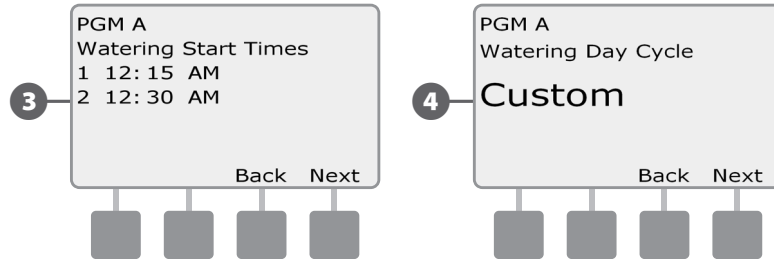

- The Watering Days review screen appears with allowed watering days displayed. Press Next.
- The Run Times review screen appears with run times for each station displayed. Press Next.

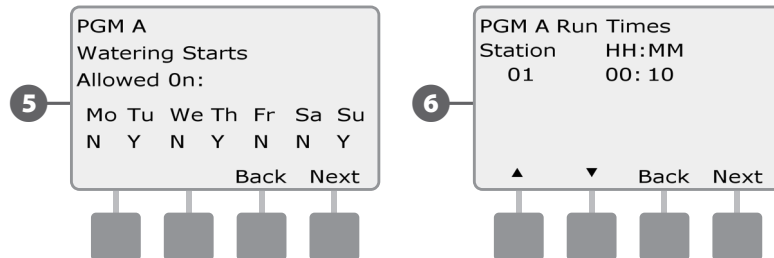

- 7 The Seasonal Adjust review screen appears with seasonal adjustment percentage displayed. Press Next.
- 8 The Seasonal Adjust by Month review screen appears with seasonal adjustment percentage displayed for the first allowed month. Press the + and - buttons to see Seasonal Adjust percentage for other months as desired; then press Next.

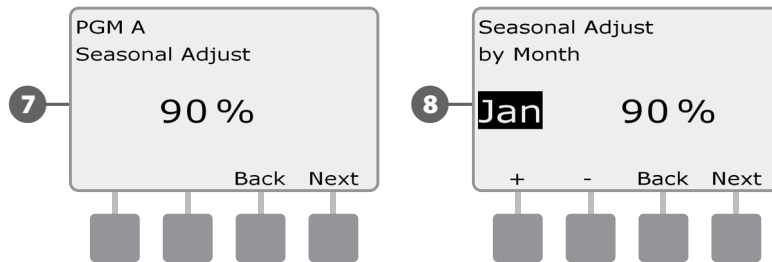

- 9 The Rain Delay review screen appears with number of days remaining until next watering date displayed. Press Next.
- 10 The Calendar Day Off review screen appears with all selected calendar days off displayed. Press Next.

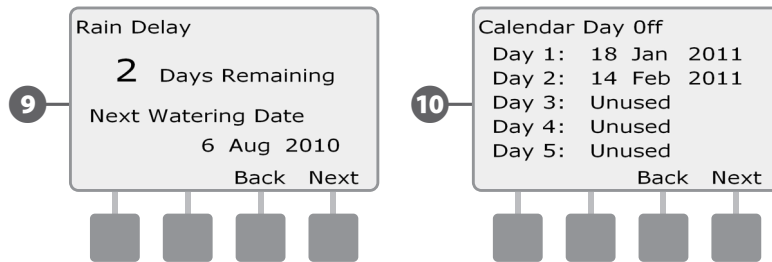

- 11 The Station Delay review screen appears with delay time between stations displayed. Press Next.
- 12 The Cycle+Soak Minutes review screen appears with the Cycle+Soak times for each station displayed. Press Next.

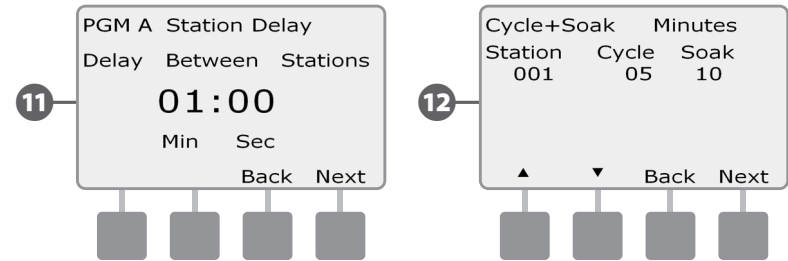

- 13 The Master Valve Assignment review screen appears with MV information displayed. Press Next.
- 14 The Weather Sensor Assignment review screen appears with stations that use sensor override displayed. Press Next.

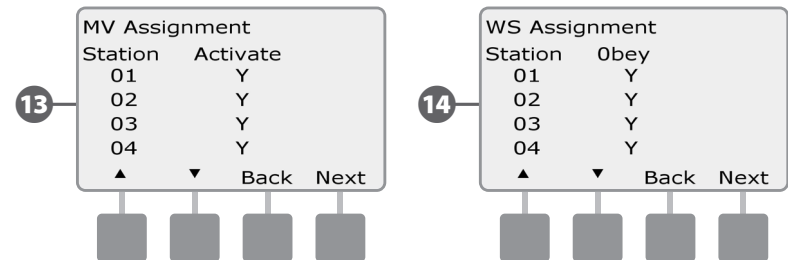

- 15 The Water Window review screen appears with water window open time, close time and duration displayed. Press Next.
- 16 The Maximum Number of SimulStations for program review screen appears with the maximum number of stations that can operate simultaneously for that program are displayed. Press Next.

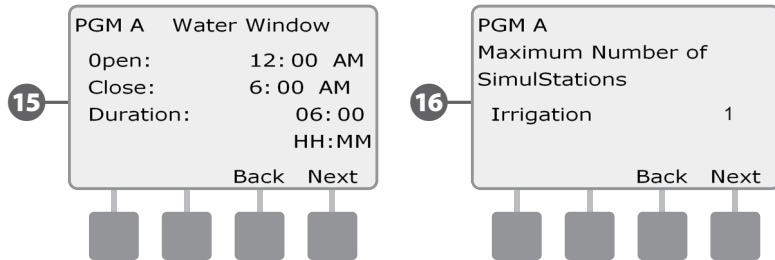

- 17 The Maximum Number of SimulStations for controller review screen appears with the maximum number of stations that can operate simultaneously for that controller are displayed. Press Next.
- 18 The Backup Programs review screen appears with the Contractor Default backup program status displayed. Press Next.

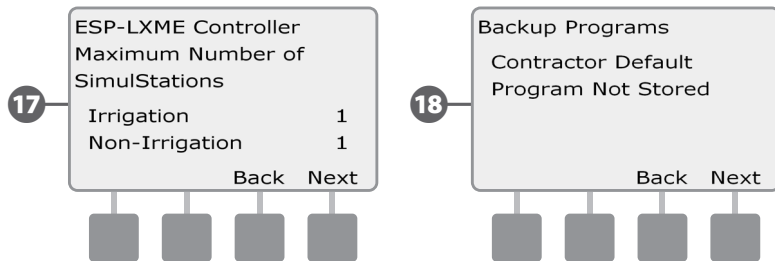

Program Run Time

Review total Run Time for an individual program:

- Turn the controller dial to Test All Stations/Check System.

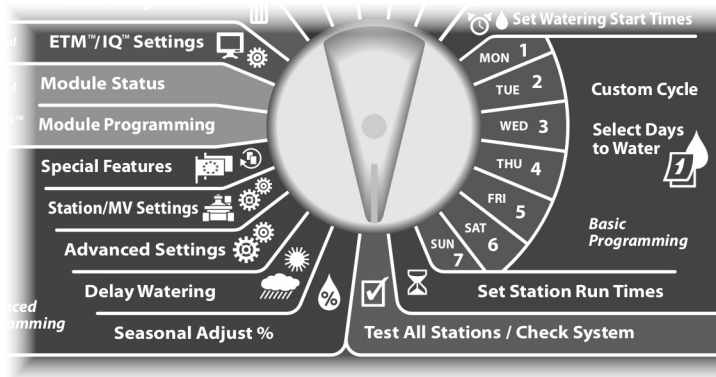

- The Check System screen appears with Confirm Programs selected; press Next.
- The Confirm Programs screen appears. Press the Down Arrow button to select Program Run Time; then press Next.

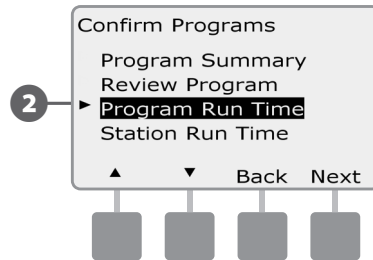
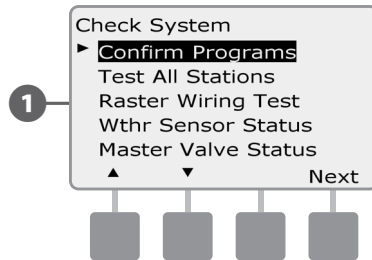

- The Total Run Time screen appears and total Run Time is displayed for the currently selected program.

NOTE: If the desired program is not selected, use the Program Select switch to change it. See Section B, Program Select Switch for more details.

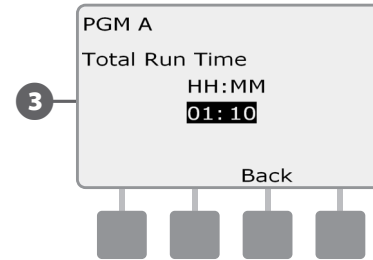

NOTE: For stations set up for Cycle+Soak, the Cycle Time (when irrigation is occurring) will be included in Program Run Time calculations but Soak times will NOT be included. See Section D, Set Up Cycle+Soak, for more details.

NOTE: The total program run time is the cumulative total run time if stations are run one at a time. If SimulStations have been set to more than 1, total irrigation time will be less.

Change the Program Select switch and repeat this process to review and confirm Program Run Times for other programs as desired.

Station Run Time

Review total Run Time for all stations:

- Turn the controller dial to Test All Stations/Check System.

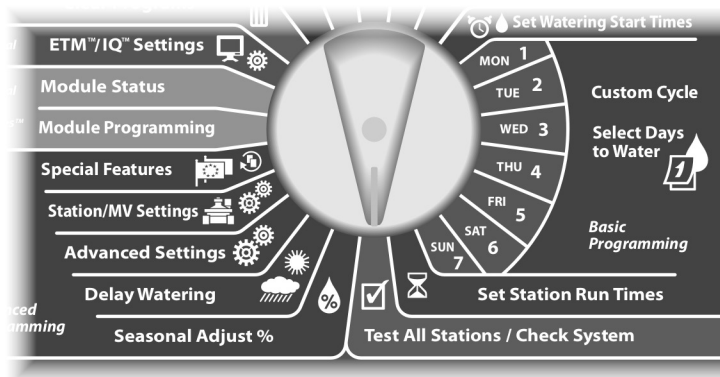

- The Check System screen appears with Confirm Programs selected; press Next.
- The Confirm Programs screen appears. Press the Down Arrow button to select Station Run Time; then press Next.

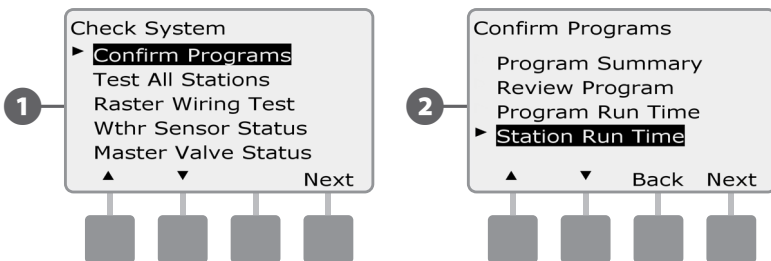

- The Sta Run Time Per Day screen appears with total Run Time displayed for the currently selected station in all four programs. For programs where a particular station is not used no runtime will show.

- Press the + and - buttons to advance and see additional stations.

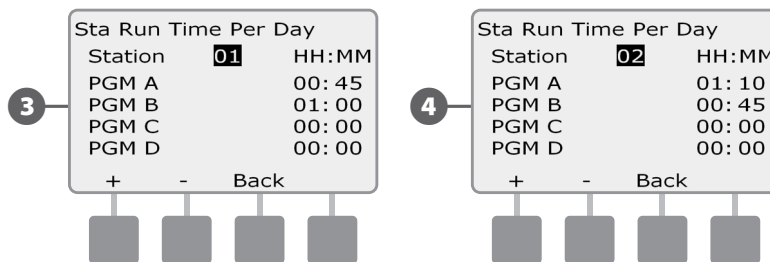

- NOTE:** Soak times for stations set up with Cycle+Soak are not included in the Station Run Time calculations. See Section D, Set Up Cycle+Soak for more details.

Test All Stations

You can test all stations connected to your controller by running each of them in station number sequence.

Sometimes this is useful after installation, for general maintenance or as a first step in troubleshooting your system.

! **NOTE:** Only stations with programmed run times are included in the Test All Stations operation.

▶ Turn the controller dial to Test All Stations/Check System.

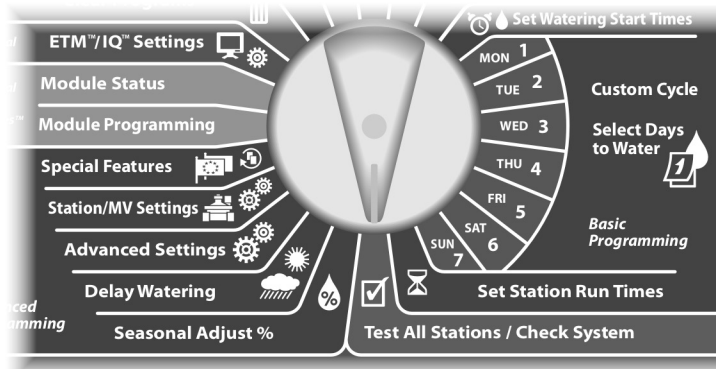

- 1** The Check System screen appears. Press the Down Arrow button to select Test All Stations; then press Next.
- 2** The Test All Stations screen appears. Press the + and – buttons to adjust the Test Run Time (adjustable from 1 to 10 minutes) per station; then press Run.

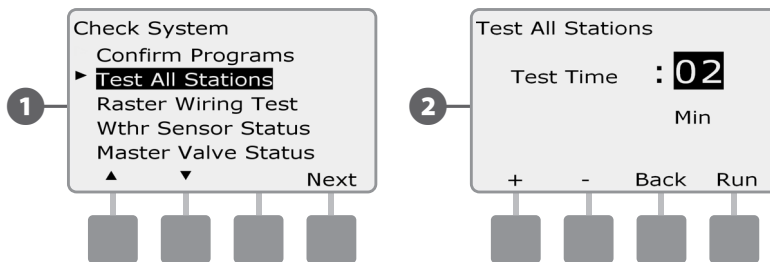

- 3** A confirmation screen appears.
- 4** Once Run is pressed, stations can be monitored and advanced by turning the dial to the AUTO position and using the Adv button. Press the + and – buttons to increase or decrease Run Time minutes for the current station.

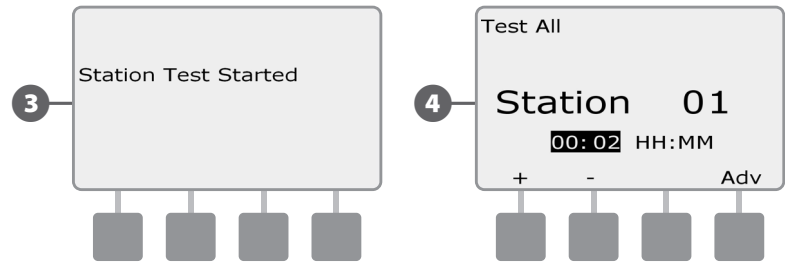

Wiring Diagnostics

Although finding the exact location of issues in the field often requires some amount of in-the-field troubleshooting, the controller has some built-in features to help you narrow down the possible issues.

Before beginning diagnostics, it may be helpful to take the following steps to eliminate possible other causes:

1. Review and Confirm Programs to check station priorities.

If a suspect station isn't watering as scheduled, the underlying issue could be programming-related. The ESPLXME-ET controller can be configured to operate stations in order of station number or station priority. If Station Sequencing by Station Priority mode is enabled and multiple programs are running, higher priority stations will irrigate prior to medium priority stations, and medium priority stations will irrigate prior to lower priority stations. See Confirm Programs in this section for more details.

2. Run a Test All Stations check to ensure valves are working properly.

The Test All Stations manual test will take priority above pre-programmed irrigation and allow you to determine which stations are working properly. See Test All Stations for more details.

Raster Wiring Test

The ESPLXME-ET controller can quickly test to determine if any stations have shorted or open wires or valve solenoids.

- Turn the controller dial to Test All Stations/Check System.

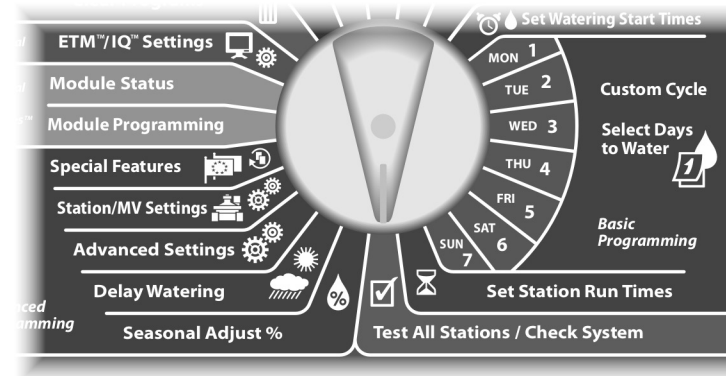

- The Check System screen appears. Press the Down Arrow button to select Raster Wiring Test; then press Next.
- The Raster Wiring Test screen appears. The test begins automatically.

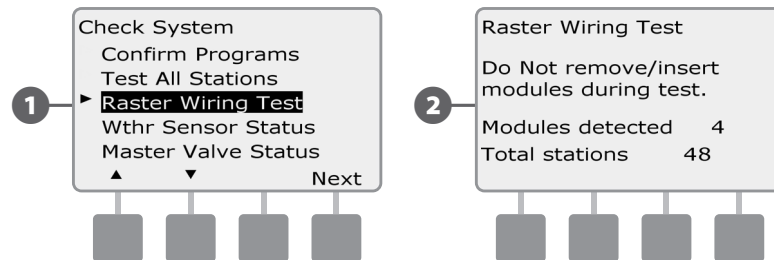

- NOTE:** During the test every installed station number is briefly displayed on the screen.

- When the test is complete, the results are displayed on the screen. Press the + and - buttons to scroll through all stations that have short circuits or open circuits.

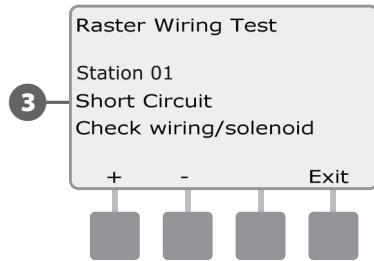

Weather Sensor Status

Turn the controller dial to Test All Stations/Check System.

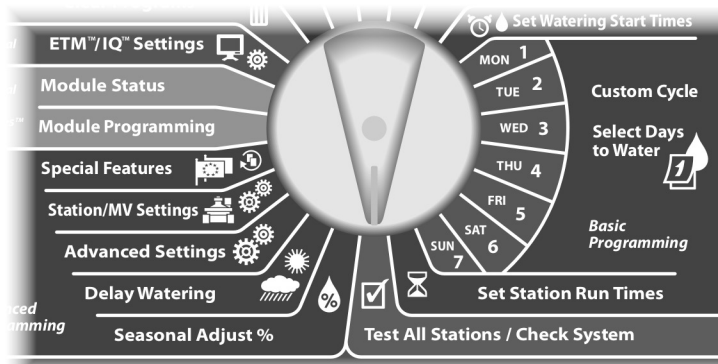

- 1 The Check System screen appears. Press the Down Arrow button to select Wthr Sensor Status; then press Next.
- 2 The Weather Sensor Status screen appears, showing the status of the installed weather sensor.

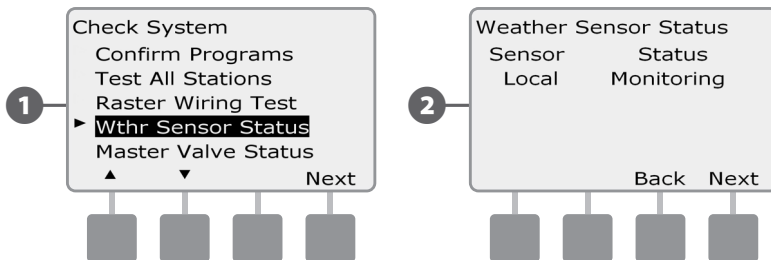

The sensor will display one of five status conditions:

- a. Monitoring - sensor is active monitoring current weather conditions.
- b. <Inactive> installation has not been completed or the sensor is not linked to any stations.
- c. PAUSING - current weather condition has caused the sensor to pause irrigation.
- d. PREVENTING - current weather condition has caused the sensor to prevent irrigation.
- e. BYPASSED - sensor switch is in the Bypassed position and the sensor is not monitoring current weather conditions.

! **NOTE:** If current weather conditions are sufficient for the weather sensor to prevent or pause irrigation, then a message appears on the Auto screen. This is not considered an alarm, so the controller alarm light will not illuminate.

Master Valve Status

- Turn the controller dial to Test All Stations/Check System.

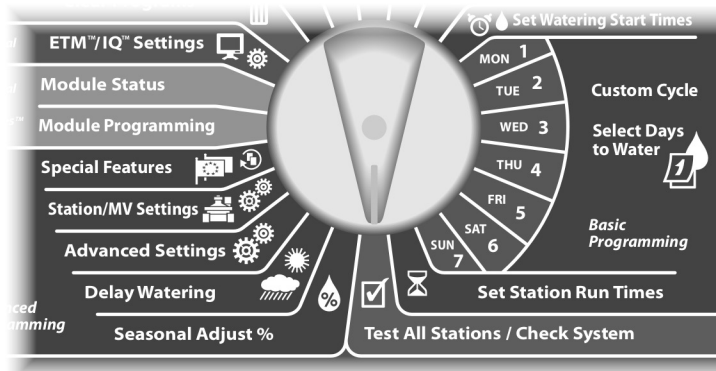

- The Check System screen appears. Press the Down Arrow button to select Master Valve Status; then press Next.
- The MV Status screen appears, showing the status of the installed master valve.

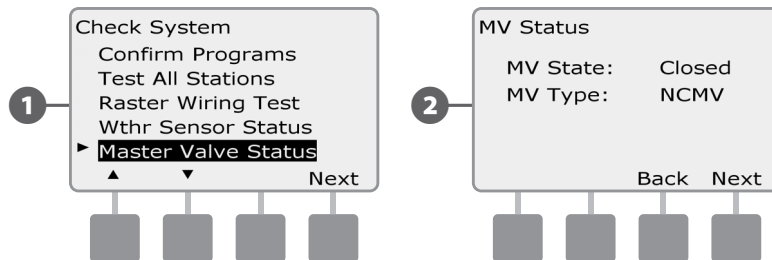

ET Manager Alert Messages

When the ET Manager generates a Weather Interrupt or detects a problem or fault in the system, an Alert Message is displayed. The following table lists all the possible Alert Messages (in alphabetical order) and the appropriate course of action to resolve the issue.



NOTE: Pressing **Ok** when an Alert Message is displayed will temporarily clear the message from the display, but does not solve the problem. Active alerts can be viewed by pressing **Alrt** on the Moisture Levels screen.

Message	Probable Cause	Action
1 Hour Rain Interrupt	If rainfall over the last hour is at or above the 1 Hour Rain setting, watering is interrupted. Once the total rainfall in the last hour drops below the 1 Hour Rain setting, the 1 Hour Rain Interrupt will clear.	NONE. Watering will resume when the total effective rainfall within an hour falls below your set threshold.
24 Hour Rain Interrupt	If rainfall over the last 24 hours is at or above the Rain Interrupt setting, watering is interrupted. Once the total rainfall in the last 24 hours drops below the Rain Interrupt setting, the 24 Hour Rain Interrupt will clear.	NONE. Watering will resume when the total effective rainfall within 24 hours falls below your set threshold.
Display Completely Blank	Possible power failure or unit reset during firmware upgrade.	Do not remove power or reset the ETC unit for 10 min. or until firmware upgrade is complete.
Historical ET is NOT set	The ET Manager Cartridge uses historical ET values set by the user as a backup in the event weather signal service is not available. If no Historical ET has been programmed, this message is displayed.	Monthly historical ET values for your area are available on the Weather Reach™ Signal Provider information sheet and from the Historical ET database included in the ET Manager Cartridge Resource CD. Look up your city and state, then program the monthly values into the ET Manager Cartridge (see the Set Historical ET section).
Local Rain Gauge Input Failure Check Wiring	If you are using a Rain Gauge to collect rain data and there is a problem with the input to the Rain Tip Wire terminal then this message is displayed.	Verify the on-site Rain Gauge is installed and wired properly. Check the length of the Rain Gauge wire for cuts or nicks and replace any damaged wire. Check the Rain Gauge for damage. Once any wiring problem is corrected, turn the dial to the ETM™/IQTM or ETM™/IQTM/PBCTM position. From the Moisture Levels screen, press the Alrt button to view the Alert Message and press CLEAR. If the problem persists, the Alert will return.

Message	Probable Cause	Action
<p>Low Weather Signal Accuracy</p>	<p>If data reception accuracy is less than 50% then the Low Weather Signal Accuracy message is displayed. There are 4 reasons the Weather Signal Accuracy may be low:</p> <p>The Signal Accuracy % is based on the last 16 days, so if there was a period of no data, it will take time for the % to increase.</p> <p>Signal service has been canceled by the Weather Reach™ Signal Provider.</p> <p>The Signal Provider is having technical difficulties.</p> <p>Weak radio reception.</p>	<p>Weak radio reception or radio interference may cause missed weather signals. A Remote Mounting Kit may be needed to improve radio reception. Contact your Rain Bird Distributor to find out more information about an optional Remote Mounting Kit (ETM – RMK). Turn the dial to the ETM™/IQTM or ETM™/IQTM/PBCTM position. From the Moisture Levels screen, press the Alrt button to check for other Alert Messages and refer to trouble shooting for applicable message(s). It may be that your WRSP had system problems that interrupted the weather signal for a period of time. If data continues to be missed for several days, contact your WRSP, to check if there has been interruption in the weather signal.</p> <p>NOTE: A calculated ET value based on previously received weather information and the historical ET programmed in your ET Manager will be used.</p>
<p>No Paging Signal Detected</p>	<p>The ET Manager Cartridge verifies the presence of the Paging Signal every minute. If the paging signal is not detected after a period of time, this message will be displayed. There are 3 reasons the weather signal would not be detected;</p> <p>The radio needs to be reset.</p> <p>The Signal Provider Code has not been set correctly.</p> <p>Weak radio reception.</p>	<p>If this Alert Message occurs, wait two minutes to ensure the weather signal will not be detected within the next few minutes. If the Alert Message remains, follow these steps:</p> <p>Follow the steps in the Weather Signal section to test the Weather Signal.</p> <p>From the Weather Signal screen, press More, then Reset, then Back.</p> <p>Wait two minutes. If the Signal changes from “Not Detected” to “Detected,” your paging signal has been restored.</p> <p>Verify the Signal Provider Code is programmed correctly. If the code was programmed incorrectly, enter correct values and repeat steps 1 and 2 as needed.</p> <p>If the Signal Provider Code is programmed correctly and the Alert Message remains, an external mounting kit may be needed to improve radio reception. Contact your Rain Bird Distributor to find out more information about an optional Remote Mounting Kit (ETM-RMK).</p>

Message	Probable Cause	Action
No Signal, Service Activation Required, Please Contact Signal Provider	A Weather Reach™ Signal Provider (WRSP) may offer weather signal service on a subscription basis, requiring activation. If the terms of service have not been met the WRSP may deactivate signal reception. In this case the ET Manager Cartridge will continue to function utilizing Historical ET.	Contact your Weather Reach™ Signal Provider to establish services and activate your signal. To find your WRSP, go online at www.rainbird.com/wrsp or contact your Rain Bird Distributor.
Radio Initialization Failure Press ET Manager Cartridge Reset	Your ET Manager Cartridge uses a radio to receive the weather signal. If the ET Manager Cartridge is experiencing radio initialization problems, this message will appear.	The radio may need to be re-initialized. To do so, press the Reset button on the ET Manager Cartridge. If the problem persists, the ET Manager Receiver must be replaced. Contact your Rain Bird Distributor.
Radio Failure	Your ET Manager Cartridge uses a radio to receive the weather signal. If the ET Manager Cartridge has detected a radio failure, this message will appear.	The radio may need to be re-initialized. To do so, press the Reset button on the ET Manager Cartridge. If the problem persists, the ET Manager Receiver must be replaced. Contact your Rain Bird Distributor.
Signal Provider Code is NOT set	The ET Manager Cartridge has not been programmed with a Signal Provider Code.	Enter the appropriate Signal Provider Code. To obtain your Signal Provider Code, go on line to www.rainbird.com/wrsp or contact your Rain Bird Distributor.
Temperature Interrupt	If the hourly weather signal contains air temperatures that reach or are below the Temperature Interrupt setting, watering is interrupted. Once the air temperature rises above the programmed interrupt setting as received in the hourly weather signal, the Temperature Interrupt will clear.	NONE. Watering will resume when the temperature exceeds your set threshold.
Wind Interrupt	If the hourly weather signal contains wind speeds that reach or exceed the Wind Interrupt setting, watering is interrupted. Once the wind speed decreases below the programmed interrupt setting, as received in the hourly weather signal, the Wind Interrupt will clear.	NONE. Watering will resume when the wind slows down below your set threshold.

Landscape Condition Issues

If you notice the landscape is too dry or wet, the following table lists suggestions to help resolve the issue. The most important factor for consideration is the health of the landscape.



NOTE: If you need assistance or advice on landscape issues, call the ET Manager Hotline at: 1-877-351-6588.

Condition	Probable Cause	Action
<p>Dry or wet spots in the landscape</p>	<p>Dry and wet spots are often caused by inefficiency in the distribution of water by your irrigation system.</p>	<p>Check the sprinkler heads near the spot that is dry or wet. It is possible that a broken or clogged head or nozzle needs to be replaced.</p> <p>Check the layout of your sprinkler design. Proper sprinkler designs should ensure head to head coverage. Changing a nozzle size, adding or moving a head may improve water distribution.</p> <p>If steps 1 and 2 do not solve the problem, check the run times in the ESP-LX Controller. Adding or subtracting time for the station where the spot appears may compensate for minor irrigation system inefficiencies.</p> <p>NOTE: Manual watering to a dry spot will speed recovery. Adjust the run time using small intervals of time, 1 or 2 minutes. Monitor the spot after an adjustment has been made. This will help determine what run time is optimal to prevent dry or wet spots.</p>
<p>Entire station or zone is too dry or wet</p>	<p>Stations or zones are the distinct areas in your landscape watered by one valve. Dry or wet stations or zones are often caused by a run time problem programmed in the controller.</p>	<p>Start the zone to confirm that the zone is operating properly.</p> <p>Check the run time on your ESP-LX Controller for the station. The dry or wet station can be caused by too little or too much watering.</p> <p>Manually water the station if it is too dry to get it the water it needs.</p> <p>Adjust the run time using small intervals of time, 1 or 2 minutes. This will help determine what run time is optimal to prevent dry or wet stations.</p>

Condition	Probable Cause	Action
Several stations in a program are too dry or too wet	<p>There are two possible causes for all the stations in a program being too dry or too wet:</p> <p>A run time problem programmed in your controller.</p> <p>The Irrigation Amount.</p>	<p>If the program is too dry, manually water the program to get it the water it needs.</p> <p>Check the run times in your ESP-LX Controller. The dry or wet program can be caused by too little or too much run time for each station.</p> <p>Adjust the run time(s) using small intervals of time. This will help determine what run time is optimal to prevent dry or wet stations.</p> <p>If steps 1 and 2 do not fix this problem, adjust the Irrigation Amount for the program.</p> <p>NOTE: You want to decrease your Irrigation Amount if you are experiencing a wet program, and increase your Irrigation Amount if you have a dry program.</p>
The site is watering every day	<p>There are three possible causes why the site is watering everyday:</p> <p>ET rates are high enough that daily watering is necessary (no action is required)</p> <p>The Irrigation Amount(s) are programmed too low.</p> <p>The Minimum Run Time Limit is programmed too low.</p>	<p>The Irrigation Amounts could be programmed too low. The total Irrigation Amount should be equal to or above peak historical ET values. See the Irrigation Amount and Station Run Times section in the Appendix for more details.</p> <p>The Minimum Run Time Limit lets you decide the smallest percentage of the watering cycle you will allow to run. Setting the Minimum Run Time Limit to 0% means that with each amount of ET received the ET Manager Cartridge will try to replace the water immediately even if it means running the Programs for only 1% of their scheduled time. Adjust the Minimum Run Time up (default setting is 80%).</p>
I want to water on the next cycle	There may be occasions when, in your judgment, the sprinklers should water the next watering cycle.	To water the next cycle you may manually start the program(s), or adjust the Moisture Levels for the selected program(s) to 0 (see the Moisture Levels section).

Condition	Probable Cause	Action
<p>After a rainstorm my irrigation system resumes watering too soon</p>	<p>There are several reasons which could cause the irrigation system to resume watering too soon after a rainstorm:</p> <p>The rainfall received in the weather signal may not correctly represent rainfall at your site.</p> <p>Location of your optional on-site Rain Gauge may be ineffective.</p> <p>The Rain Source in the ET Manager Cartridge may be programmed incorrectly.</p> <p>Effective Rain settings may need to be adjusted.</p>	<p>The weather signal rainfall value may not correctly represent rainfall at your site. Connect an optional on-site Rain Gauge (ETM-RG).</p> <p>Check the location of your optional on-site Rain Gauge, make certain there are no obstacles blocking rain from entering the Rain Gauge.</p> <p>Check the Rain Source to verify the ET Manager Cartridge is programmed to use data from the correct Rain Source and correct gauge ETM-RG 1mm/tip or Local Gauge 0.01"/tip (RAINGAUGE) (see the Rain Source section for details).</p> <p>The Maximum Hourly Rain setting may be limiting the amount of rainfall applied to the Moisture Levels. Change the Maximum Rain to a higher amount to accept more hourly rainfall in the Moisture Levels (see the Effective Rain section for details). For example, if Max Hourly Rain is set to 0.25" and rain for the last hour is 1.00", only 0.25" will be added to the Moisture Level.</p> <p>The Saturation Allowance may be too low. Change the Saturation Allowance to a higher amount to accept more rainfall in the Moisture Level(s) (see the Effective Rain section for details).</p>
<p>After a rainstorm my irrigation system does not resume watering soon enough</p>	<p>There are several reasons the irrigation system may not resume watering soon enough after a rainstorm:</p> <p>The rainfall received in the weather signal may not correctly represent rainfall at your site.</p> <p>The Rain Source in the ET Manager Cartridge may be programmed incorrectly.</p> <p>Effective Rain settings may need to be adjusted.</p>	<p>The weather signal rainfall value may not correctly represent rainfall at your site. Connect an optional on-site Local Rain Gauge (ETM-RG).</p> <p>Check the Rain Source to verify the ET Manager Cartridge is programmed to use data from the correct Rain Source.</p> <p>The Maximum Hourly Rain setting may be accepting more rainfall into the Moisture Levels than the landscape is actually capable of accepting. Change the Maximum Hourly Rain to a lower amount to limit rainfall in the Moisture Levels.</p> <p>The Saturation Allowance may be too high. The Saturation Allowance creates a limit to the amount of rain that can accumulate in the Moisture Level(s). Change the Saturation Allowance to a lower amount to decrease the amount of rainfall that can accumulate in the Moisture Level(s).</p>

Condition	Probable Cause	Action
<p>It was raining and the sprinklers were running</p>	<p>There are several reasons the irrigation system may be watering during a rainstorm:</p> <p>The rainfall received in the weather signal may not correctly represent rainfall at your site.</p> <p>The Rain Source in the ET Manager Cartridge may be programmed incorrectly.</p> <p>Rain Interrupt settings may need to be adjusted.</p>	<p>The weather signal rainfall value may not correctly represent rainfall at your site. Connect an optional on-site Local Rain Gauge (ETM-RG).</p> <p>Check the Weather Info for the last hour of rain to verify the rain data is being reported by your ET Manager Cartridge.</p> <p>Check the Rain Source to verify the ET Manager Cartridge is programmed to use data from the correct Rain Source. If correct check the Rain Gauge for proper functionality (you may need to contact your Weather Reach™ Signal Provider).</p> <p>Program a 1 Hour Rain Interrupt to stop watering until rain accumulations reach below the programmed 1 Hour Rain Interrupt setting.</p> <p>Program a 24 Hour Rain Interrupt to cancel watering until rain accumulations reach below the programmed 24 Hour Rain Interrupt setting.</p>

Section D - Advanced Programming

The ESPLXME-ET controller has a wide variety of advanced but easy-to-use features designed to simplify irrigation.

Seasonal Adjust %

The ET Manager Cartridge manages watering by changing the Seasonal Adjust percentage value. This increases or decreases the programmed watering run times for each station. When watering is not needed, the Seasonal Adjust percentage will be set to 0% to conserve water. When watering is needed, the Seasonal Adjust percentage will increase to meet watering needs.

NOTE: See Weather-Based Irrigation Control in the Introduction & Overview section for details.

The Seasonal Adjust % should be set to 100% and controlled by the ET Manager, unless fine-tune adjustments to the watering schedule are necessary. Seasonal adjustments can be managed by month or by program.

CAUTION: Multiple Seasonal Adjustment settings affect each other and can significantly impact irrigation. For example, if you set a program-level Seasonal Adjustment of 10% and then a monthly Seasonal Adjustment of 10%, irrigation will be reduced to 1% of normal (10% of 10%). Consider using only one type of Seasonal Adjustment setting.

CAUTION: Setting a small number for the Seasonal Adjustment percentage will greatly reduce watering and setting to 0% will cancel irrigation entirely. Use caution when making Seasonal Adjustment settings.

Adjust Individual Program

Turn the controller dial to Seasonal Adjust %.

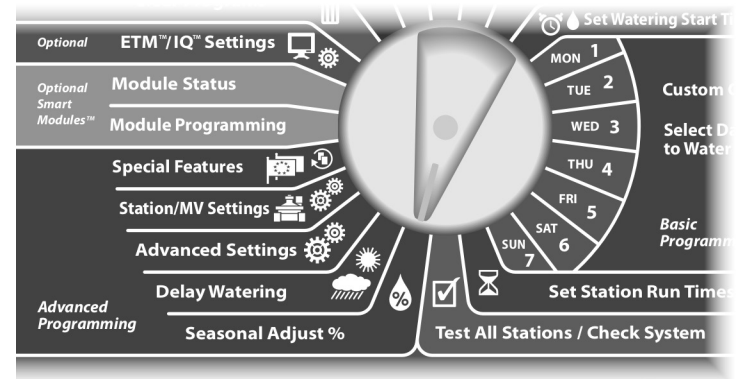

- 1 The Seasonal Adjust screen appears with Individual PGM selected; press Next.
- 2 Press the + and - buttons to set the seasonal adjustment percentage (from 0 - 300%).
 - Press and HOLD buttons to accelerate settings for percentages.

NOTE: If the desired program is not selected, use the Program Select switch to change it. See Section B, Program Select Switch for more details.

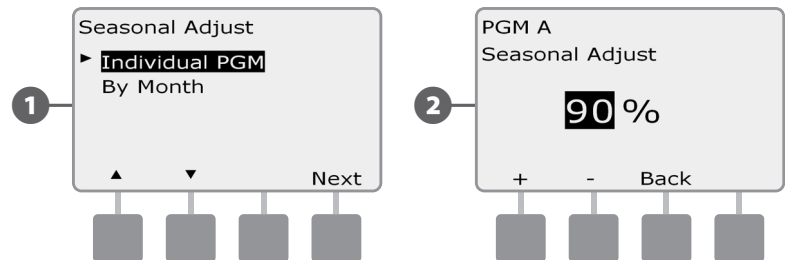

- Change the Program Select switch and repeat this process to set Seasonal Adjustments for other programs as desired.

Adjust By Month Select Months to Adjust

- Turn the controller dial to Seasonal Adjust %.

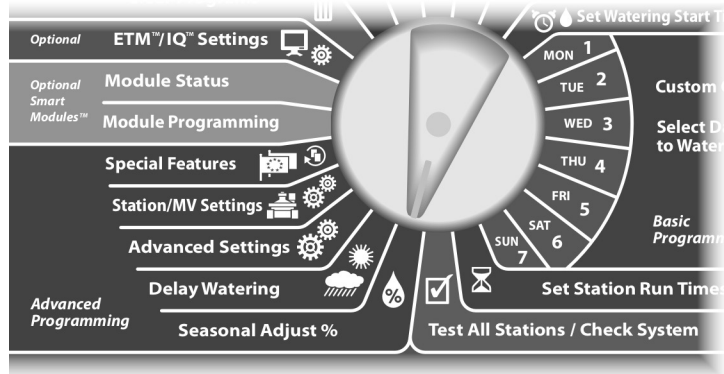

- The Seasonal Adjust screen appears. Press the Down Arrow button to select By Month; then press Next.
- The Seasonal Adjust by Month screen appears with % Adjust selected; press Next.

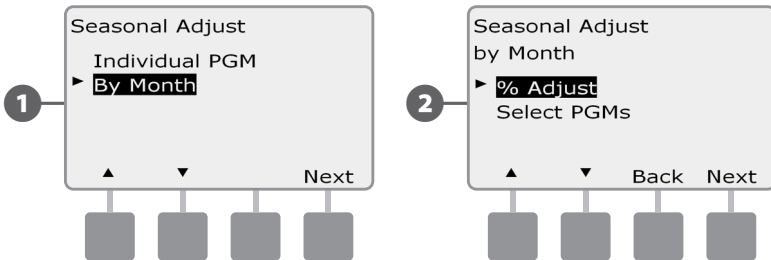

- Press the + and – buttons on the left to select the month you would like to adjust.
- Press the + and – buttons on the right to set the Seasonal Adjustment percentage (from 0 - 300%).
 - Press and HOLD buttons to accelerate settings for percentages.

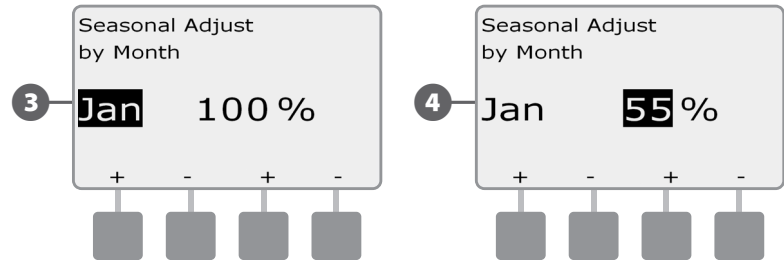

- Repeat this process to set Seasonal Adjustments for other months as desired. Then change the Program Select switch and repeat this process to set Seasonal Adjustments By Month for other programs as desired.

NOTE: The % Adjust will automatically change to the new month's percentage setting on the first day of the month.

Select Programs To Adjust

- ▶ Turn the controller dial to Seasonal Adjust %.

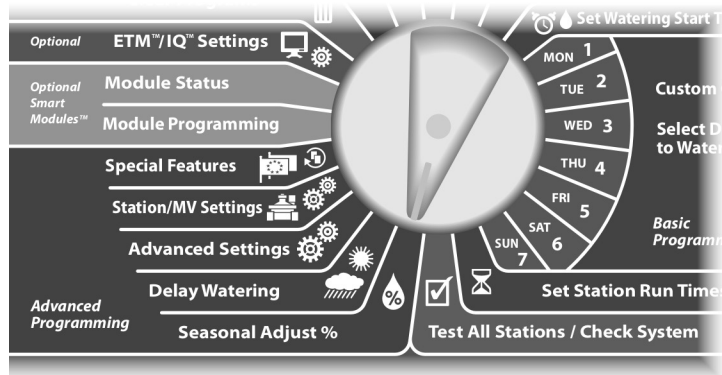

- 1 The Seasonal Adjust screen appears. Press the Down Arrow button to select By Month; then press Next.
- 2 The Seasonal Adjust by Month screen appears. Press the Down Arrow button to select Select PGMs; then press Next.

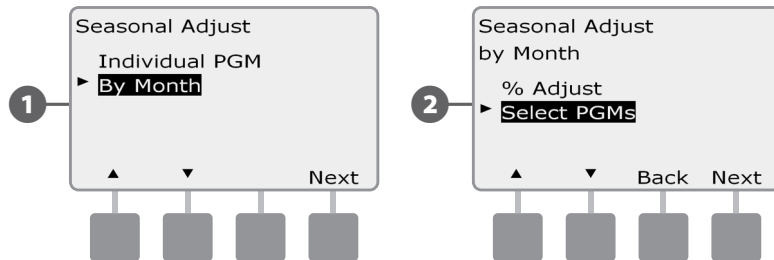

- 3 Press the Yes or No buttons to set Monthly Adjust for the current selected program.
- 4 To set another program, change the Program Select switch to the desired program; a confirmation appears.

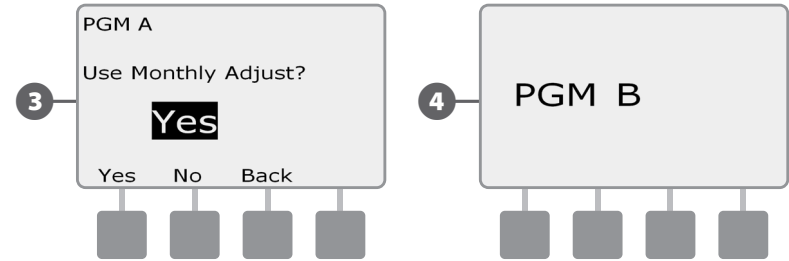

- ↻ Repeat this process to set Monthly Adjustments for other programs as desired.

Delay Watering

Rain Delay

The ESPLXME-ET controller's Rain Delay feature lets you discontinue irrigation for a few days after a period of heavy rain.

The ESPLXME-ET can also be equipped with an optional Rain Bird ET Manager Cartridge to automatically calculate and automate rain shutdown. Ask your Rain Bird distributor for more details or visit the Rain Bird web site, www.rainbird.com.

NOTE: If you have a rain sensor attached to your controller, it may be unnecessary to manually program a Rain Delay. Consult the rain sensor device documentation for more details.

Turn the controller dial to Delay Watering.

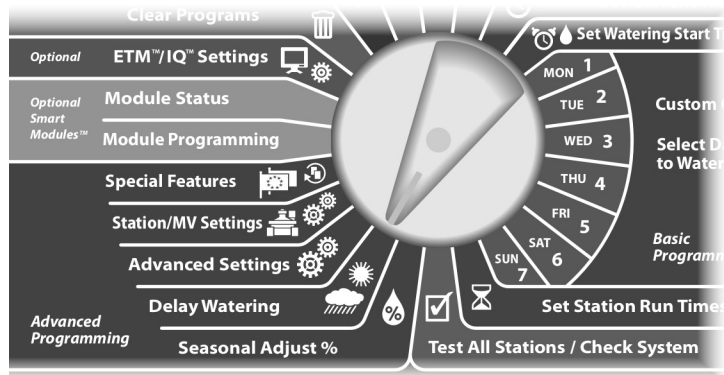

- 1 The Delay Watering screen appears with Rain Delay selected; press Next.
- 2 The Rain Delay screen appears. Press the + and – buttons to set the number of days (from 0 to 14 days) for the Rain Delay. The next irrigation date after the Rain Delay calculates and displays automatically.

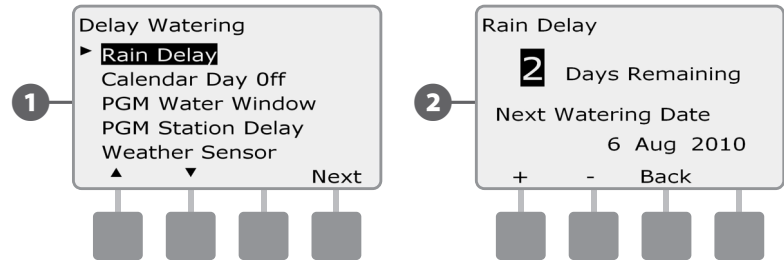

NOTE: A Rain Delay affects all programs, but stations set up as Non-irrigation will still run during a Rain Delay.

Calendar Day Off

You can schedule certain days of the year as Non-irrigation, such as holidays when landscape may receive heavy use.

The ESPLXME-ET controller can be programmed to suspend irrigation on a particular calendar date, up to 5 different days of the year.

! **NOTE:** Calendar Day Off dates can only be selected 365 days in advance. Then once a Calendar Day Off has passed, it will be removed from the list and must be reprogrammed for the following year if desired.

▶ Turn the controller dial to Delay Watering.

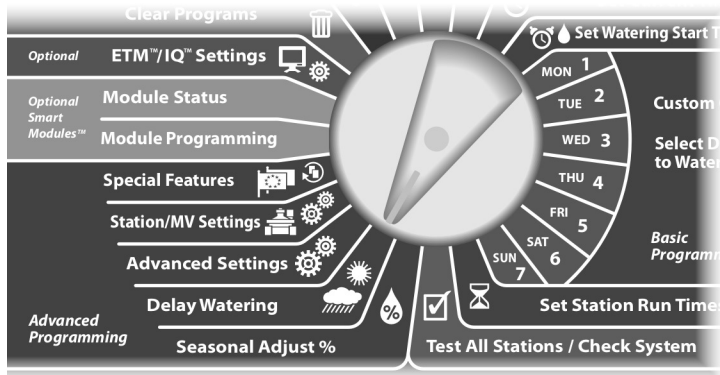

- 1** The Delay Watering screen appears. Press the Down Arrow button to select Calendar Day Off; then press Next.
- 2** The Calendar Day off screen appears, showing (up to 5) scheduled calendar days off in chronological order. Unprogrammed days will show as Unused.

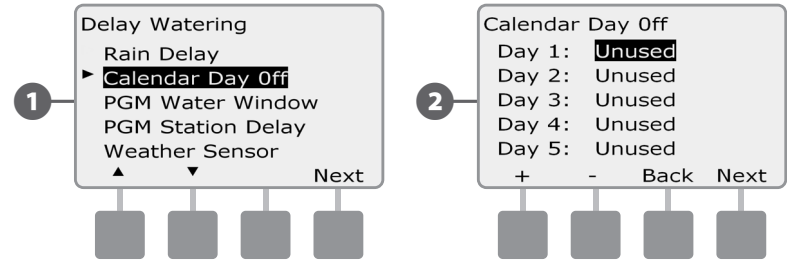

- 3** Press the + and – buttons to set the Calendar Day Off date as desired. Press the Next and Back buttons to select other days as desired.
 - Press and HOLD buttons to accelerate settings for dates.

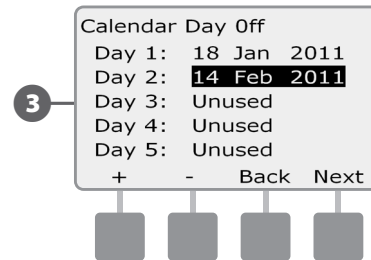

! **NOTE:** Calendar Day Off affects ALL programs and stations, including non-irrigation stations. Consider not using this feature if any of your programs include essential functions such as door locks or sports field lighting.

Water Windows

Used to specify certain times of the day/night when irrigation is allowed.

Otherwise watering is not allowed outside these “Water Windows”. This is helpful to comply with local regulations which may prohibit irrigation during certain hours.

CAUTION: Be sure a Water Window is sufficient to allow irrigation programs to run completely. Irrigation scheduled outside the Water Window will not run but will resume when the Water Window opens again. This can cause irrigation programs to “stack” and eventually create an alarm condition if the controller stacks 8 or more programs.

NOTE: Water Windows can be scheduled to cross midnight. For example, a Water Window can start at 10:00 PM and continue until 4:00 AM the next morning. Be sure your Watering Start Times are set to occur within the Water Window. See Section B, Set Watering Start Times for more details.

Turn the controller dial to Delay Watering.

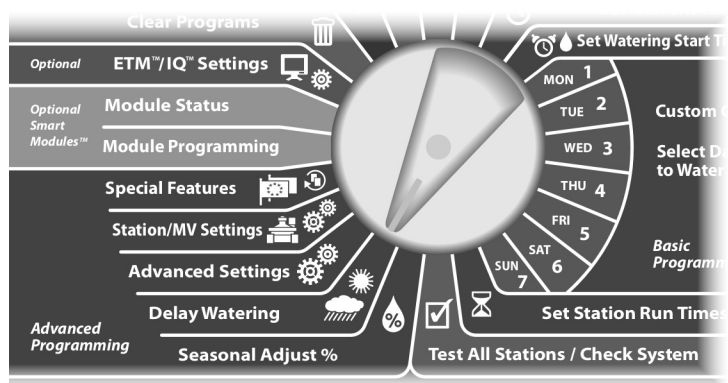

- 1 The Delay Watering screen appears. Press the Down Arrow button to select PGM Water Window; then press Next.
- 2 The Water Window screen appears. Press the + and – buttons to set the time when the Watering Window opens; then press Next.
 - Press and HOLD buttons to accelerate settings for hours and minutes.

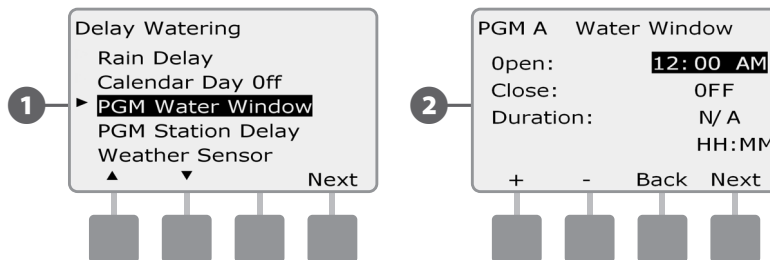

- 3 Press the + and – buttons to set the time when the Watering Window closes. As you adjust the close time, the duration of your Water Window calculates automatically.

NOTE: To clear a previously set Water Window, press the + and – buttons to set both the Open and Close times to OFF (between 11:59 and 12:00 AM).

- 4 To set another program, change the Program Select switch to the desired program; a confirmation appears.

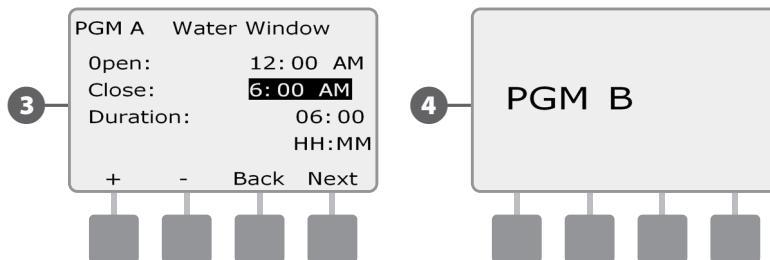

- Repeat this process to set or clear Water Windows for other programs as desired.

Station Delay

The ESPLXME-ET controller can be programmed to include a delay between stations.

This feature delays the start of the next sequential station in a program after the previous station completes.

CAUTION: Consider using short Station Delay times, particularly if your watering schedule or Water Window is short. Long delay times could prevent scheduled irrigation from completing prior to the end of the Water Window. See previous Water Windows for more details.

Turn the controller dial to Delay Watering.

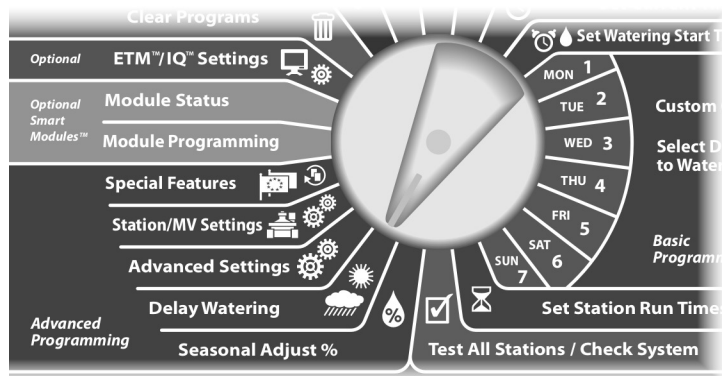

- 1 The Delay Watering screen appears. Press the Down Arrow button to select PGM Station Delay; then press Next.
- 2 The Station Delay screen appears. Press the + and – buttons to set the delay time (from 00:01 second to 10:00 minutes). To clear Station Delay on that station, set to 00:00; then press Next.
 - Press and HOLD buttons to accelerate settings for minutes and seconds.

NOTE: If the desired program is not selected, use the Program Select switch to change it. See Section B, Program Select Switch for more details.

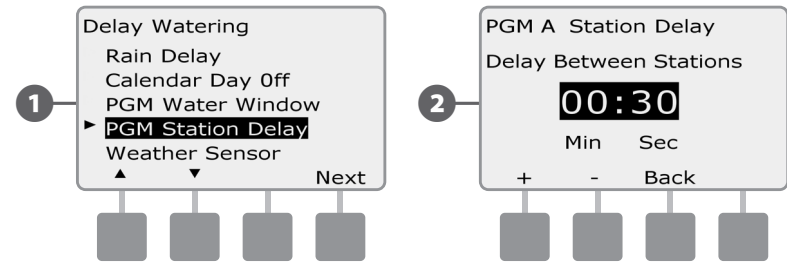

Change the Program Select switch and repeat this process to set Station Delay for other programs as desired.

Weather Sensor

A weather sensor is not required for the ESPLXME-ET controller, but it can increase functionality by allowing you to prevent or pause irrigation based on changing weather conditions.

The ESPLXME-ET supports one local weather sensor, via a wireless or wired connection to the LXME Controller base module.

Local Weather Sensor Types

Five types of local weather sensors are supported:

Sensor Types	
Type	Action
Rain	Prevent
Wind	Pause
Freeze	Pause
Soil Moisture	Prevent
Custom Pause	Pause
Custom Prevent	Prevent

Custom Pause Sensors

When a weather condition becomes true, a Custom Pause sensor will stop irrigation and also stop the irrigation timer. When the condition becomes false again, irrigation will start exactly where it left off. For example, if a station is set to irrigate for 20 minutes but is shut down by a Pause sensor after only 5 minutes; when the weather condition becomes false again and after Resume, that station will receive the full remaining 15 minutes of irrigation left on the timer.

Custom Prevent Sensors

When a weather condition becomes true, a Custom Prevent sensor will stop irrigation but allow the irrigation timer to continue to run. When the condition becomes false again, irrigation will resume at the same time had the weather condition never occurred. For example, if a station is set to irrigate for 20 minutes but is shut down by a Prevent sensor after only 5 minutes, if the condition becomes false again after 10 minutes then that station will only receive the remaining 5 minutes of irrigation left on the timer.

Weather Sensor Setup

- Turn the controller dial to Delay Watering.

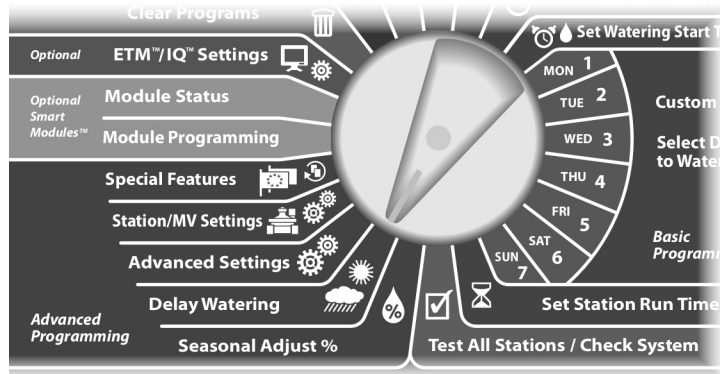

- 1 The Delay Watering screen appears. Press the Down Arrow button to select Weather Sensor; then press Next.
- 2 The Weather Sensor Setup screen appears. Press the + and - buttons to set the weather sensor type; then press Next.

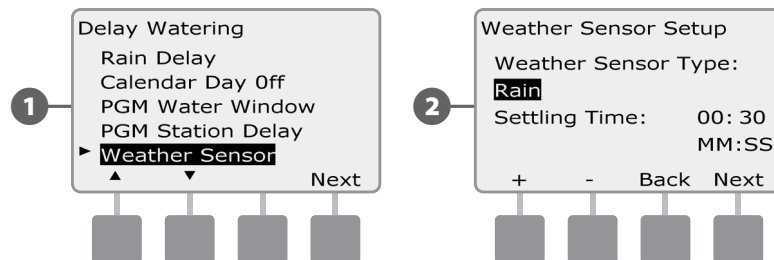

- 3 Press the + and - buttons to set the Settling Time; then press Next.

NOTE: Settling time is how long a weather condition must last before the controller takes action. For example, if a freeze sensor has a 5 minute settling time then the temperature would have to remain below the sensor's threshold set point for 5 minutes before irrigation is paused. Settling time can be set for immediate (0 seconds) or up to 10 minutes long.

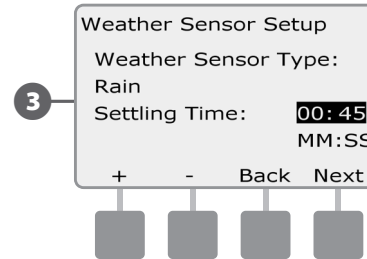

NOTE: The weather sensor is turned on (Active) or off (Bypassed) using the Weather Sensor switch on the controller front panel. This switch only affects scheduled automatic cycles. Manual watering ignores the local weather sensor.

Advanced Settings

Watering Day Cycles

The ESPLXME-ET controller supports a variety of flexible watering day cycle options.

Watering Cycle Definitions

- ◆ **Custom Days:** irrigation starts on selected days of the week.
- ◆ **Odd Dates:** irrigation starts on all odd numbered calendar days, such as the 1st, 3rd, 5th, etc.
- ◆ **Odd Dates no 31st:** irrigation starts on all odd numbered calendar days, such as the 1st, 3rd, 5th, etc., but not on the 31st.
- ◆ **Even Dates:** irrigation starts on all even numbered calendar days, such as the 2nd, 4th, 6th, etc.
- ◆ **Cyclical Dates:** irrigation starts at regular chosen intervals such as every 3rd or 5th day, regardless of the calendar date.

CAUTION: Regardless of the Watering Cycle, irrigation will start only on days of the week where program starts are allowed. See Section B, Select Days to Water for more details. It's important to select allowed irrigation days carefully to avoid landscape damage in case irrigation delays are lengthy.

NOTE: A watering cycle is selected as soon as it is highlighted with the cursor.

NOTE: Every day should be selected as a watering day if possible. The ET Manager will change the Seasonal Adjust percentages depending on the weather conditions to meet the needs of the landscape.

Custom, Odd, Odd no 31st, Even

The process for setting up Custom, Odd, Odd no 31st, and Even Watering Cycles is very similar.

Turn the controller dial to Advanced Settings.

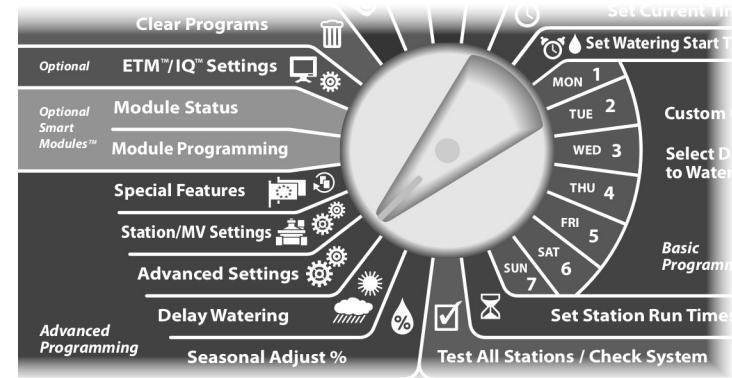

- 1 The Advanced Settings screen appears with Watering Day Cycles selected; press Next.
- 2 The Watering Cycle screen appears. Press the Down Arrow button to select Custom Days/Week.

NOTE: If the desired program is not selected, use the Program Select switch to change it. See Section B, Program Select Switch for more details.

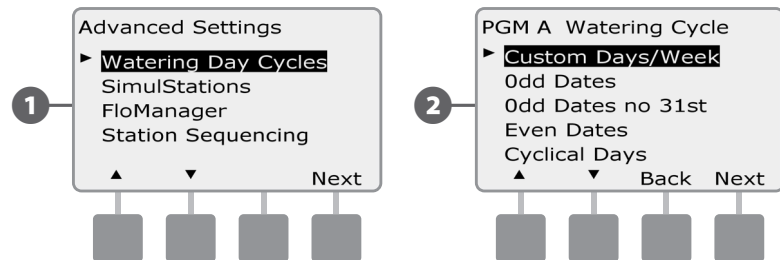

- 3 The Custom screen appears. Press the Yes button to allow irrigation to start on a given day or press No to prevent irrigation from starting.
- 4 Press the Next and Back buttons to navigate through the days of the week and repeat the selection process as desired.

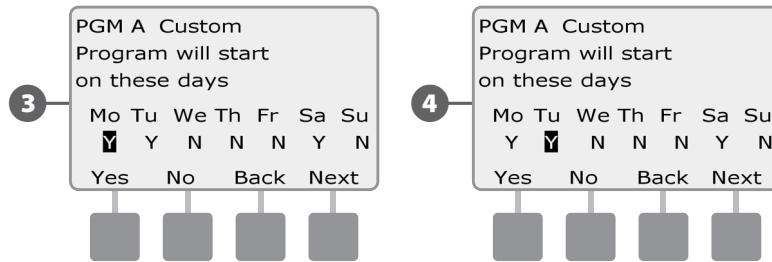

Change the Program Select switch and repeat this process to set Watering Cycles for other programs as desired.

NOTE: Watering day selections carry over to Watering Days dial positions and vice-versa. See Section B, Select Days to Water for more details.

Cyclical Days

- Turn the controller dial to Advanced Settings.

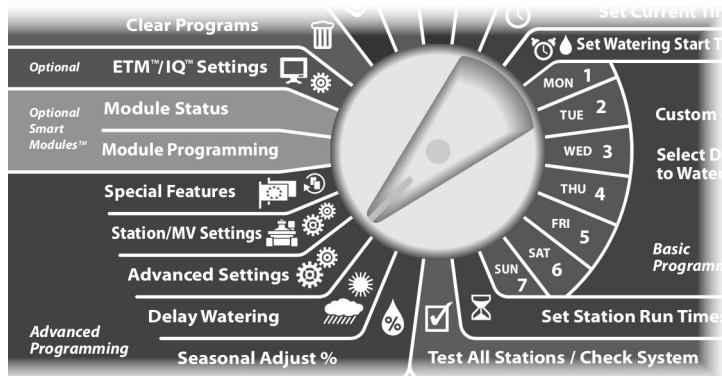

- 1 The Advanced Settings screen appears with Watering Day Cycles selected; press Next.
- 2 The Watering Cycle screen appears. Press the Down Arrow button to select Cyclical Days; press Next.

NOTE: If the desired program is not selected, use the Program Select switch to change it. See Section B, Program Select Switch for more details.

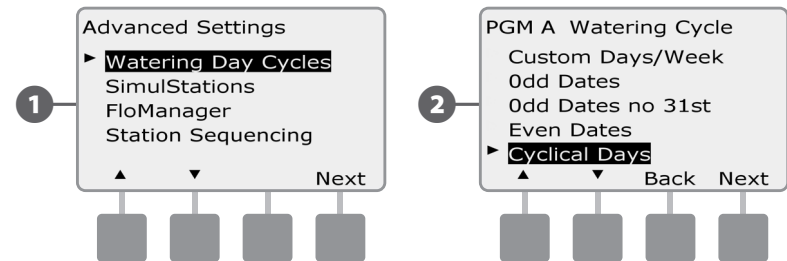

- 3 The Day Cycle Settings screen appears. Press the + and – buttons to set the watering day cycle (from 1 to 30 days). For example, set to 03 if you want to water every third day; then press Next.

- 4 Press the + and – buttons to set the first date for the Watering Cycle to begin; then press Next.

- Press and HOLD buttons to accelerate settings for dates.

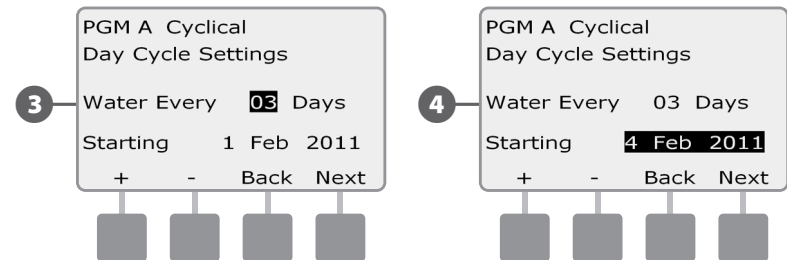

- 5 The Watering Day Cycle screen appears. Press the Yes button to allow irrigation to start on a given day of the week or else press No to prevent irrigation from starting.
- 6 Press the Next and Back buttons to navigate through the days of the week and repeat the selection process as desired.

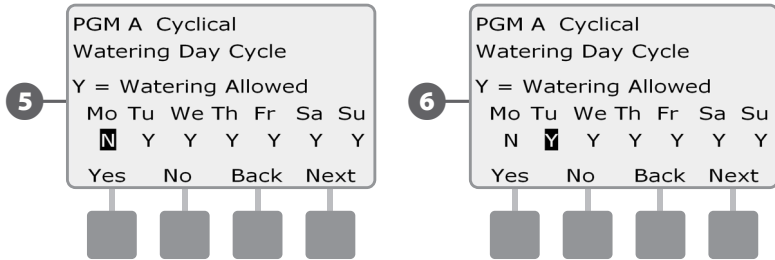

 Change the Program Select switch and repeat this process to set Cyclical Watering for other programs as desired.

 **NOTE:** Watering day selections carry over to Watering Days dial positions and vice-versa. See Section B, Select Days to Water for more details.

Set Up SimulStations™

The ESPLXME-ET controller defaults to operating a single station at a time. Systems with larger water sources may support operating two or more stations simultaneously.

SimulStations control the maximum number of stations that are allowed to operate at the same time. The number of SimulStations available depends on the number of station modules that are installed.

Maximum SimulStations	
Number of Installed Station Modules	Maximum Number of ESPLXME-ET SimulStations
1	2
2	4
3	5
4	5

NOTE: The controller will simultaneously operate a maximum of 2 stations on any single station module.

Set SimulStations™ for Program

Turn the controller dial to Advanced Settings.

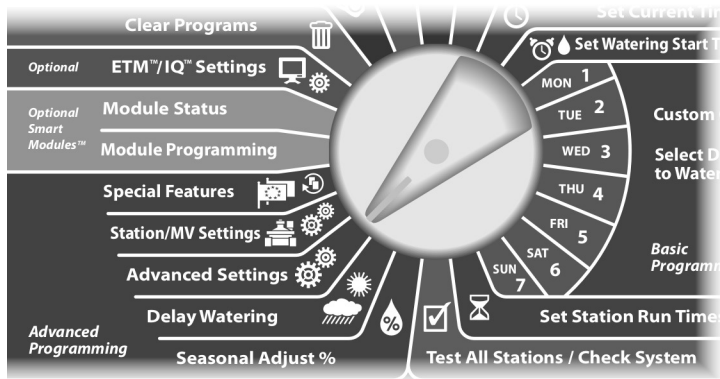

- 1 The Advanced Settings screen appears. Press the Down Arrow button to select SimulStations; then press Next.
- 2 The Station Settings screen appears with PGM SimulStations selected; press Next.

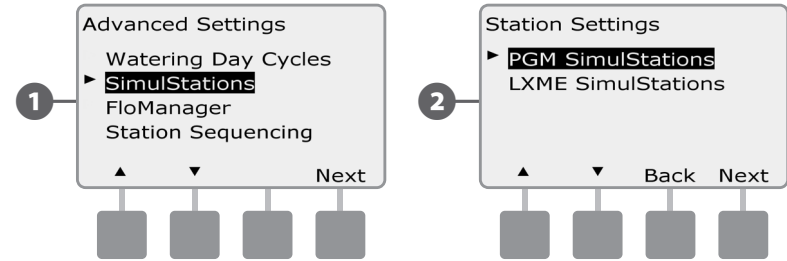

- 3 The Maximum Number of SimulStations screen appears. Press the + and – buttons to set the maximum number of irrigation stations (from 1 to 5) that can operate simultaneously for this program; then press Next.

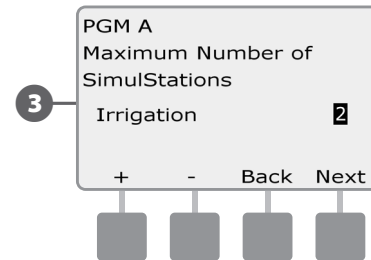

- Change the Program Select switch and repeat this process to set the Maximum Number of Stations for other programs as desired.

Set SimulStations™ for Controller

NOTE: The LXME SimulStations settings will supersede program-level settings. For example, if the LXME setting is 2 but three programs have a maximum setting of 4, then only 2 stations will be allowed to run simultaneously.

Turn the controller dial to Advanced Settings.

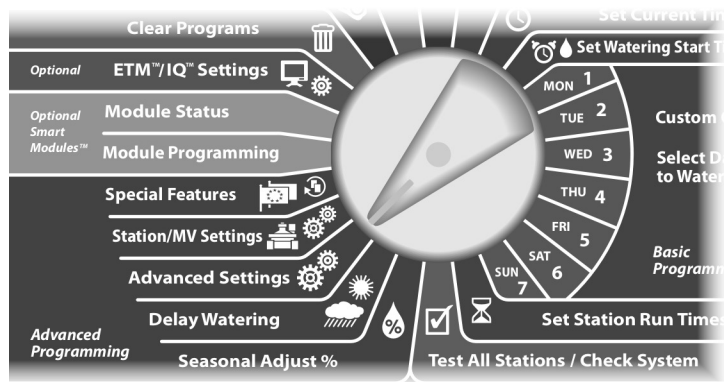

1 The Advanced Settings screen appears. Press the Down Arrow button to select SimulStations; then press Next.

2 The SimulStations screen appears. Press the Down Arrow button to select LXME SimulStations; then press Next.

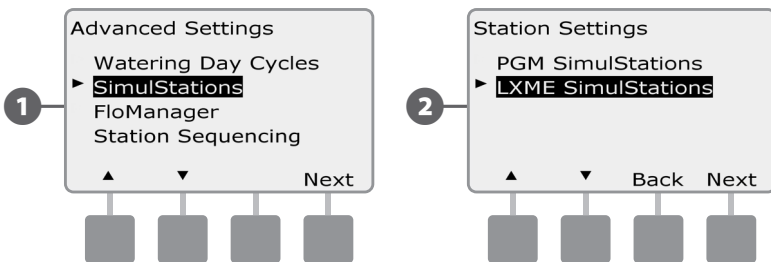

3 The ESPLXME-ET Maximum Number of SimulStations screen appears. Press the + and – buttons to set the maximum number of irrigation stations (from 1 to 5) that can operate simultaneously; then press Next.

4 Press the + and – buttons to set the maximum number of non-irrigation stations (from 1 to 5).

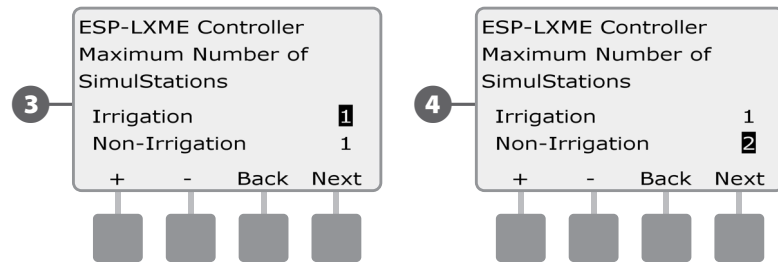

NOTE: The Non-Irrigation SimulStations setting is used to configure the maximum number of Non-Irrigation stations that can operate simultaneously and allows you to balance the number of Irrigation and Non-Irrigation stations that can operate simultaneously.

Station Sequencing

The ESPLXME-ET offers advanced programming features to optimize water windows. The Station Sequencing option allows you to select from two methods of station sequencing for program operation:

- Sequence by Station Number (system default).
- Sequence by Station Priority (required when using FloManager). This option decreases the overall time required to complete the program when operating multiple stations simultaneously.

Station Sequencing by Station Numbers will select stations to operate in the following order:

1	Station number	1 > 2 > 3 ...
2	Program assignment	A > B > C > D

NOTE: Non-irrigation priority stations will always be selected to operate first.

Station Sequencing by Station Priority will select stations to operate in the following order:

1	Station priority	Non-Irrigation > High > Medium > Low
2	Station run time	Longest run time > shortest run time
3	Station number	1 > 2 > 3 ...
4	Program assignment	A > B > C > D

NOTE: If FloManager is turned ON, then the default Station Sequencing setting is Sequence by Station Priorities. To select Station Sequencing by Station Number, FloManager must first be turned OFF. See Section E, Flow Management, Enable/Disable FloManager for more details.

Turn the controller dial to Advanced Settings.

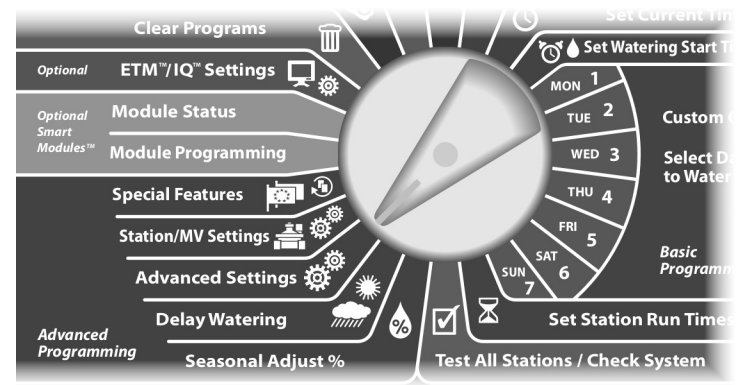

1 The Advanced Settings screen appears. Press the Down Arrow button to select Station Sequencing; then press Next.

2 The Station Sequencing screen appears. Press the + and – buttons to set Station Sequencing by either Station Numbers or Station Priorities, as desired.

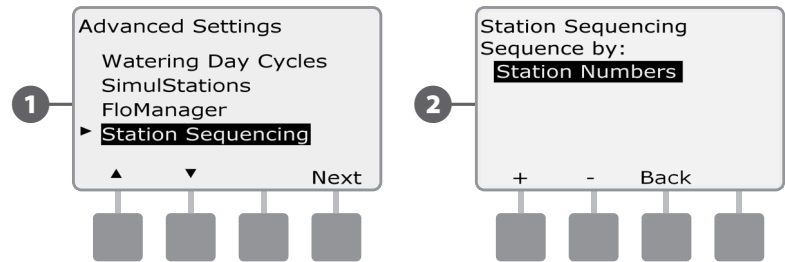

NOTE: When Station Sequencing is set to Sequence by Station Priorities, you can still manually operate stations in station number sequence using the Test All Stations option from the Manual Watering dial position. See Section G, Auxiliary Operation, Manual Watering, Test All Stations for more details.

Station/MV Settings

Station Settings

The *Station Settings* option tells the *ESPLXME-ET* controller how to interact with other stations, the master valve, and the weather sensor.

- Turn the controller dial to Station/MV Settings.

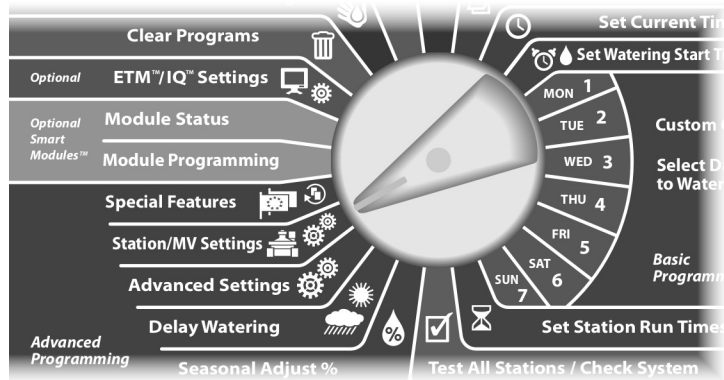

- The Station/MV Settings screen appears with Station Settings selected; press Next.
- The Station Settings screen appears. Press the + and – buttons to enter the desired station number; then press Next.

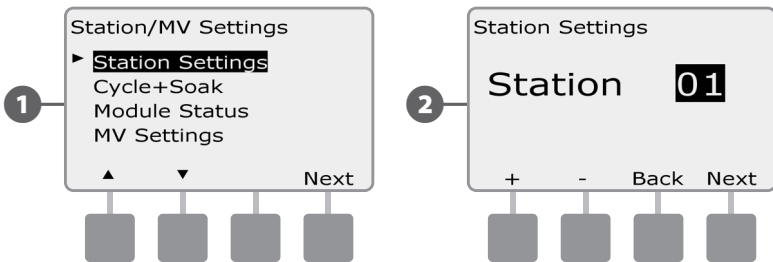

- Press the + and – buttons to enter the number of valves connected to the station; then press Next.

NOTE: Station Priorities are only used when Station Sequencing is set to Sequence by Station Priority. If you're using the default Sequence by Station Numbers, then skip the next step by pressing Next.

- Press the + and – buttons to set Station Priority. Each station can be set to High, Medium, Low or Non-irrigation. Station priority is especially important when multiple programs run simultaneously. When Station Sequencing is set to priorities, the controller will run all high priority stations first, then all medium and finally all low priority, regardless of the station's program settings. Press Next.

NOTE: Non-irrigation stations such as fountains and landscape lighting receive priority to always run, regardless of weather conditions.

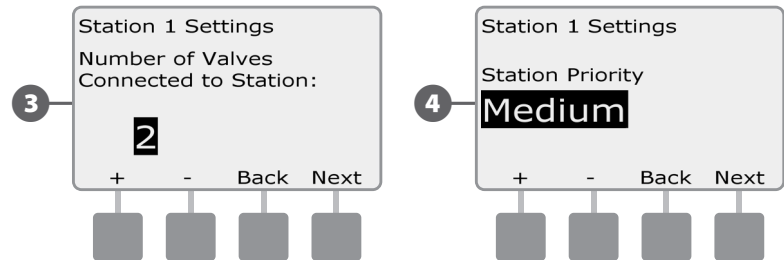

NOTE: When using Station Sequencing by priorities, set station priorities higher for stations you want selected earlier in a program and lower for stations you want selected later in a program.

- 5 Press the + and – buttons to select Yes if the station requires a master valve, otherwise select No; then press Next.
- 6 The Weather Sensor Assignment screen lets you select whether a station obeys or ignores the installed weather sensor. Press the + and – buttons to select Obey or Ignore; then press Next.

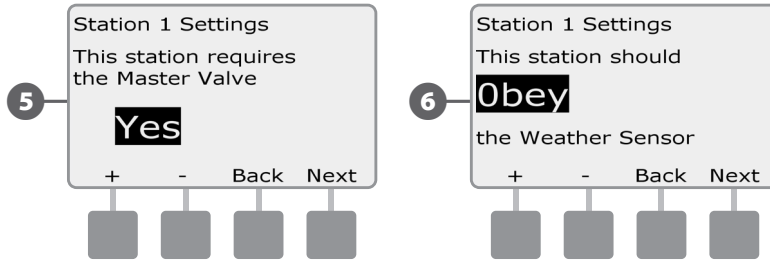

! **NOTE:** The weather sensor can be turned on (Active) or off (Bypassed) using the Weather Sensor switch on the controller front panel.

↻ Repeat this process to set up additional stations.

Set Up Cycle+Soak™

The ESPLXME-ET controller Cycle+Soak™ feature allows water to be applied to stations intermittently and without creating complex programs. It can apply to any station and is useful for locations such as hillsides which can be difficult to irrigate effectively.

Cycle+Soak consists of two settings, the cycle time (how long a station will run before soaking) and soak time (how long irrigation is paused before applying another cycle). For example, a station can be set up to receive 15 minutes of irrigation in three 5 minute cycles, with two 10 minutes periods of soak time in between waterings.

NOTE: Cycle+Soak settings apply to stations no matter which programs it may be used in.

Turn the controller dial to Station/MV Settings.

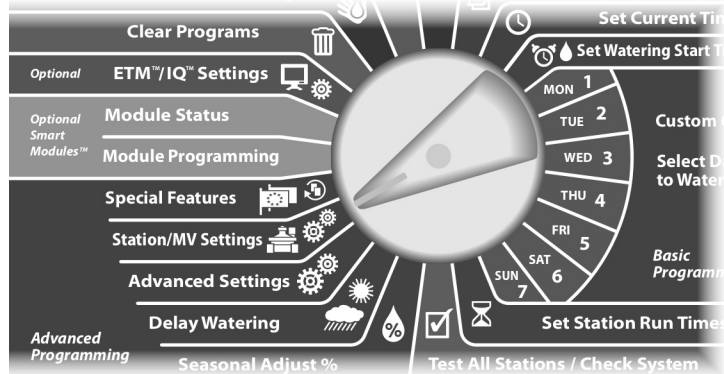

- 1 The Station/MV Settings screen appears. Press the Down Arrow button to select Cycle+Soak; then press Next.
- 2 The Cycle+Soak screen appears. Press the + and – buttons to enter the desired station number; then press Next.

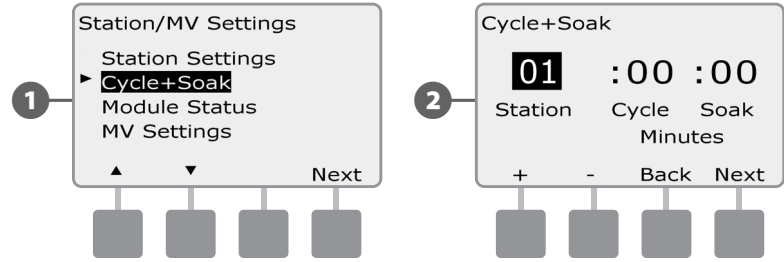

- 3 Press the + and – buttons to set the Cycle time (between 1-60 minutes). Or to cancel Cycle+Soak on that station, set to 0 minutes; then press Next.

- Press and HOLD buttons to accelerate settings for minutes.

- 4 Press the + and – buttons to set the Soak time (between 1-60 minutes). Or to cancel Cycle+Soak on that station, set to 0 minutes; then press Next.

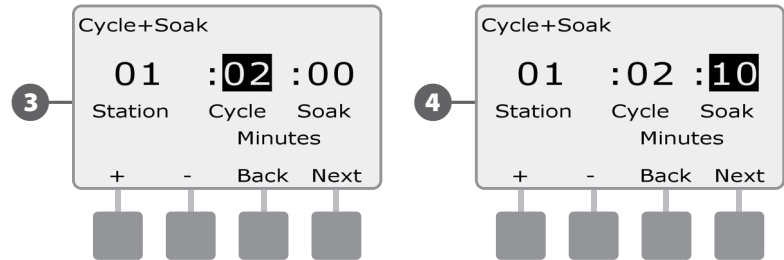

NOTE: Consider using short Soak times, particularly if your watering schedule or Water Window is short. Long soak times could prevent irrigation from completing prior to the end of the Water Window. See previous Water Windows for more details.

Repeat this process to set up Cycle+Soak on other stations.

Module Status

The **Module Status** option displays the status of any station module installed in Slots 1-4.

- Turn the controller dial to Station/MV Settings.

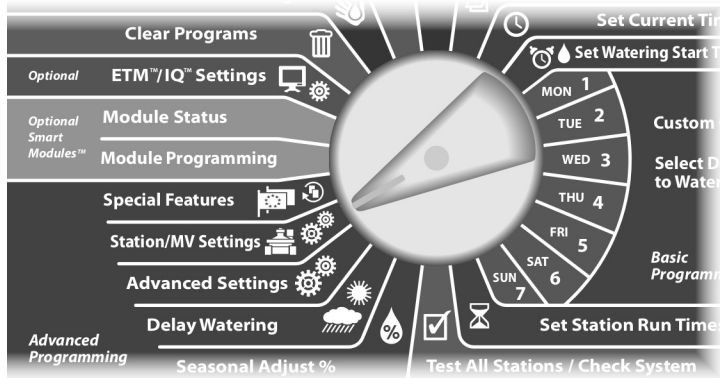

- The Station/MV Settings screen appears. Press the Down Arrow button to select **Module Status**; then press Next.
- The Module Status screen appears. The current status of any installed station modules is displayed.

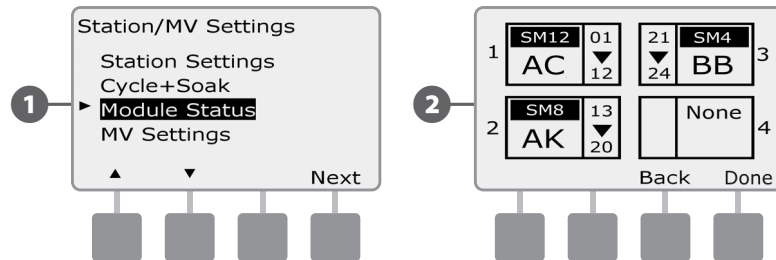

MV Settings

The MV Settings option tells the ESPLXME-ET controller what type of master valve (MV) is used by your irrigation system.

The ESPLXME-ET supports one master valve which must be set up in the controller. Both Normally Open master valves (NOMVs) and Normally Closed master valves (NCMV) are supported.

Since Normally Open master valves (NOMVs) are always open, it's sometimes helpful to cycle them closed for a minute in order to maintain the continuity of your valve diaphragms and solenoids. The controller can be programmed to perform this task automatically.

- Turn the controller dial to Station/MV Settings.

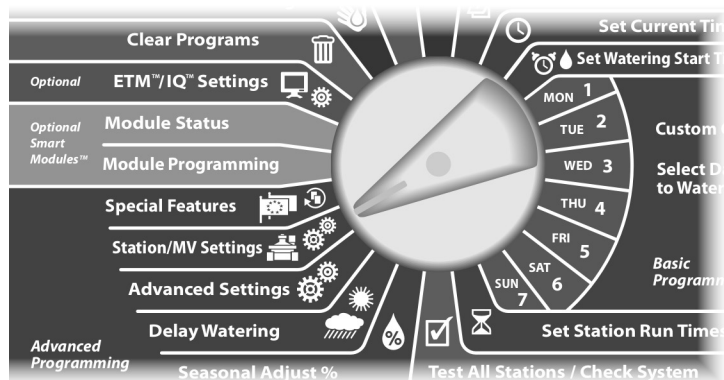

- ➊ The Station/MV Settings screen appears. Press the Down Arrow button to select MV Settings; then press Next.
- ➋ The MV Settings screen appears. Press the + and – buttons to select Normally Open or Normally Closed for the MV; then press Next.

NOTE: Standard irrigation valves are Normally Closed (powered to open). Normally Open valves are specialty valves that are powered to close.

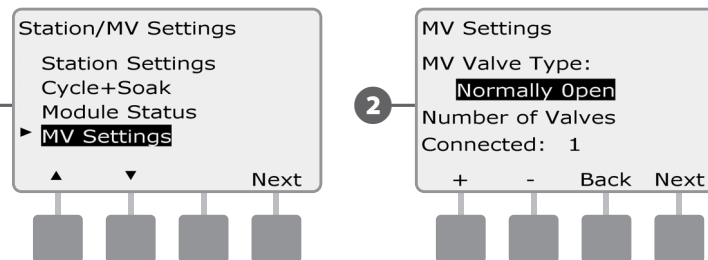

- ➌ Press the + and – buttons to enter the number of valves that are connected to the master valve circuit; then press Next.
- ➍ If the MV Valve Type is set to Normally Open, the NOMV Cycling screen appears. Press the + and – buttons to enable NOMV cycling and to select the start time; then press Next.

NOTE: The NOMV will be cycled closed for 60 seconds on the first day of each month. Since irrigation is suspended when the NOMV is shut, choose a time when irrigation is not scheduled for this operation.

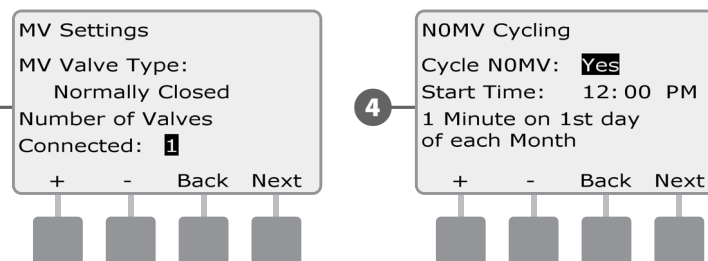

this page intentionally left blank.

ET Manager

Once the ET Manager Cartridge has been programmed, it will begin managing your watering schedules based on current weather conditions and your irrigation system capabilities.

The ET Manager shows irrigation status, keeps irrigation logs for each program, and provides system settings to customize cartridge operation.

When the ESPLXME-ET Controller dial is set to the ETM™/IQ™ (or ETM™/IQ™/PBC™) Setting position, the display and soft-keys are controlled by the ET Manager Cartridge.

! **NOTE:** Once the ET Manager Cartridge is initially installed and programmed, the Moisture Levels screen becomes the default home screen. Press Menu on the Moisture Levels screen to access the ET Manager.

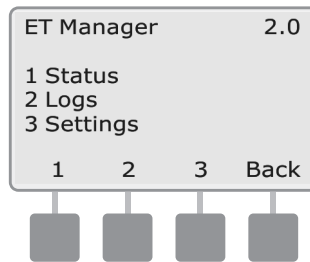

ET Manager Menu

Status Menu

Moisture Levels

Check the current irrigation status for each program.

The moisture level represents the current amount of moisture in your soil and is constantly changing due to evapotranspiration (ET), rain, or irrigation events. The ET Manager Cartridge will use the Moisture Level to set the Seasonal Adjust percentage in the ESPLXME-ET Controller.

NOTE: Moisture Levels is the default home screen for the ETM™/IQ™ (or ETM™/IQ™/PBC™) Setting dial position, and can also be accessed through the ET Manager Status Menu.

Turn the controller dial to ETM™/IQ™ (or ETM™/IQ™/PBC™) Settings.

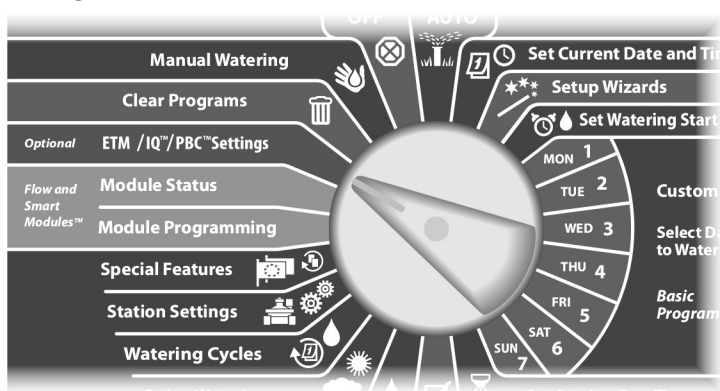

1 The Moisture Levels screen appears. The current Moisture Level is indicated graphically for each program. Press the **Adj** button to view actual Moisture Levels.

NOTE: The display indicates that Program A's Moisture Level is full while Program B's Moisture Level is low. This does NOT mean the landscape is completely dried out, only that Program B will need watering soon.

2 The current Moisture Level and Total Irrigation Amount screen for Program A appears. Press **Next** to view the next program's Moisture Level.

NOTE: Press the **+ and -** buttons to manually adjust the Moisture Level for the selected program if desired.

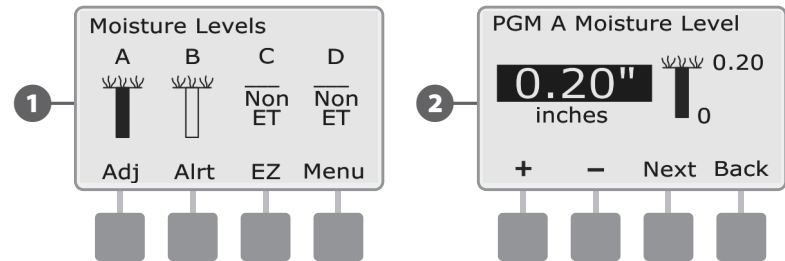

Weather Signal

Verify the status of the radio signal from your local weather station.

A Weather Reach™ Signal Provider retrieves weather information from local weather stations. The information is broadcast as a weather signal via a paging radio frequency to your ET Manager Cartridge. The weather signal contains the most recent weather conditions including: solar energy, temperature, wind, humidity, and rainfall.

- Turn the controller dial to ETM™/IQ™ (or ETM™/IQ™/PBC™) Settings; then press **Menu**.

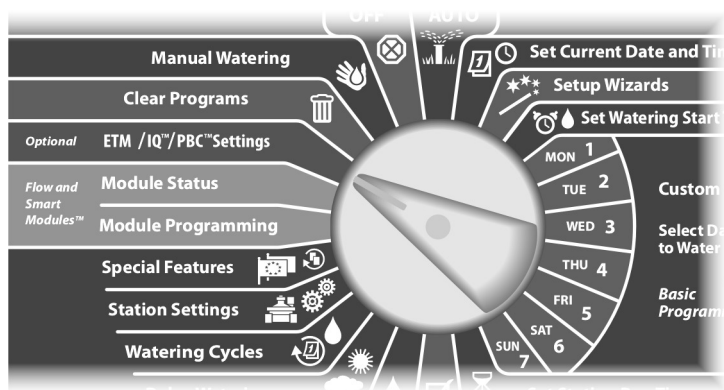

- ➊ The ET Manager screen appears. Press the **1** button to select Status.
- ➋ The Status screen appears. Press the **2** button to select Weather Signal.

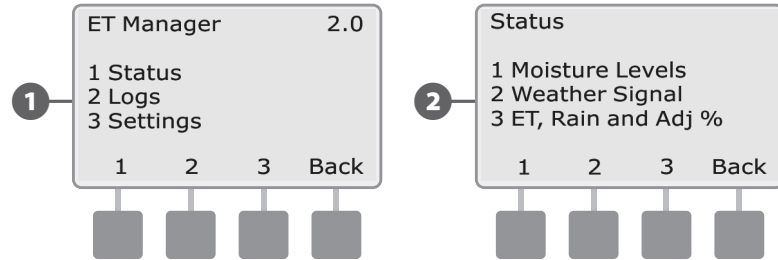

3 The Weather Signal screen appears. The status of the signal will show **"Signal Detected"** when the unit is ready to receive weather information.

! **NOTE:** If the status displays **"No Signal Detected"** wait two minutes. If the signal is still not detected, go to the Alert Messages section and follow the steps for "No Paging Signal Detected".

4 The activation status will show **"Activated"** when the unit is receiving hourly weather data for the programmed Weather Region. Press **More** to view a log of received signals.

! **NOTE:** If the activation status shows **"Not Activated"** contact your Weather Reach™ Signal Provider to establish services. (You will need to provide the Weather Reach™ Signal Provider with the ET Manager Receiver serial number, which can be found on the label attached to the receiver/antenna). Once activated the ET Manager Receiver will begin receiving hourly weather data.

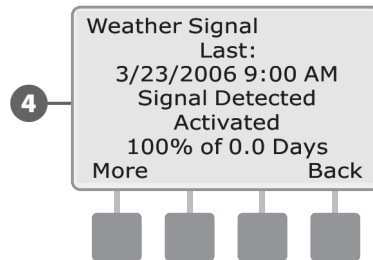
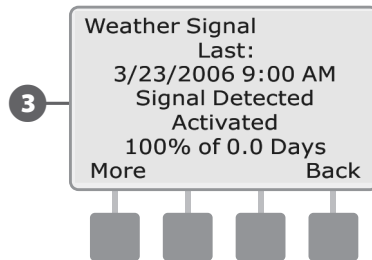

5 The Counters screen appears. Press **More** to cycle through each page.

! **NOTE:** The ET Manager retains data from every signal that is received from the weather station, Weather Region, Rain Region and the local Rain Gauge. The Counters can be reset to 0 by pressing **Reset**.

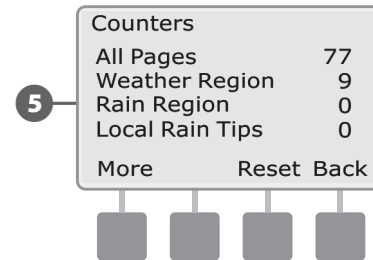

ET, Rain and Adj %

Display recent ET values, rainfall amounts and Seasonal Adjust percentages.

The ET Manager can display calculated ET values, recent rainfall amounts, current Seasonal Adjust percentages and the number of completed starts per program. ET values and rainfall amounts for the last hour, day, week, and two week period are available.

- Turn the controller dial to ETM™/IQ™ (or ETM™/IQ™/PBC™) Settings; then press **Menu**.

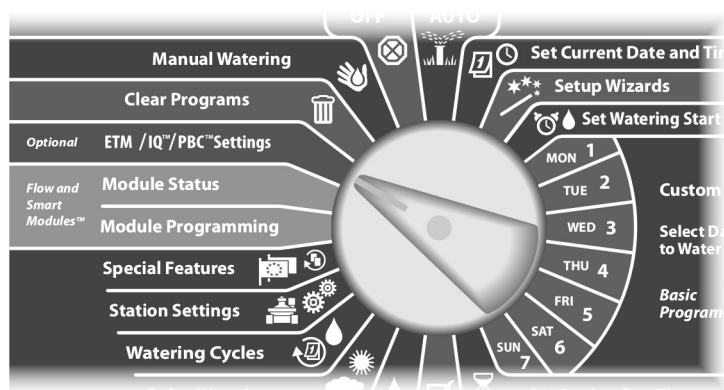

- The ET Manager screen appears. Press the **1** button to select Status.
- The Status screen appears. Press the **3** button to select ET, Rain and Adj %.

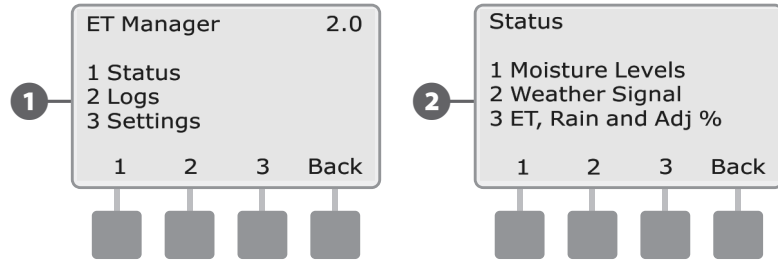

- The ET screen appears. Press **Next** to view rainfall amounts.
- The Rain screen appears. Press **Next** to view Seasonal Adjust percentages.

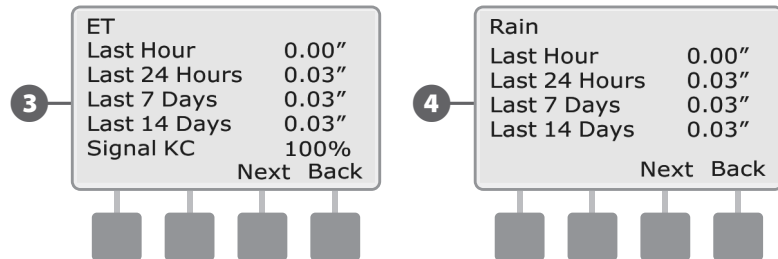

5 The Season Adjust screen appears.

5

PGM	Season Adjust	Completed Starts
A	Off	0
B	Off	0
C	Off	0
D	Off	0
Done		Back



Logs Menu

Irrigation Logs

View the irrigation history for each program.

Irrigation logs include the last irrigation date, the total number of days watered and the total estimated amount of water applied in inches since the start date.

The total number of days watered is derived from the number of completed start times. For example, if the ET Manager determines that only 2 of the 3 start times for a given program are necessary, the number of watering days added to this log will be 0.66 (2/3 of a typical watering day).

- Turn the controller dial to ETM™/IQ™ (or ETM™/IQ™/PBC™) Settings; then press **Menu**.

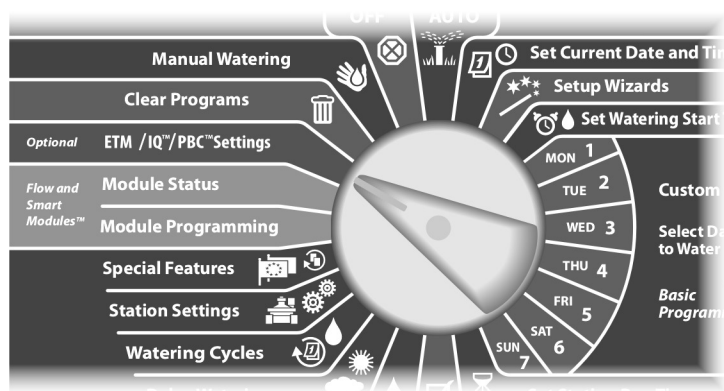

- The ET Manager screen appears. Press the **2** button to select Logs.
- The Logs screen appears. Press the **1** button to select Irrigation Logs.

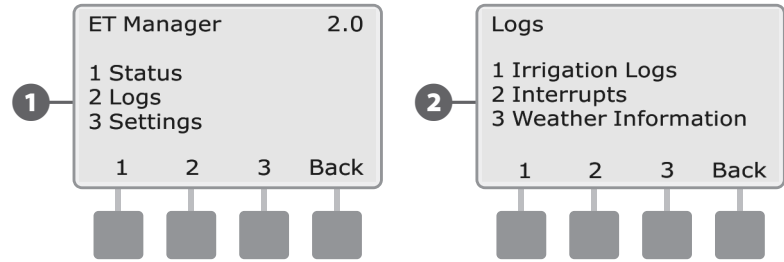

- The PGM A Irrigation Log appears. Press **Next** to view the next program's Irrigation Log.
- To clear the log, press **Clear**.

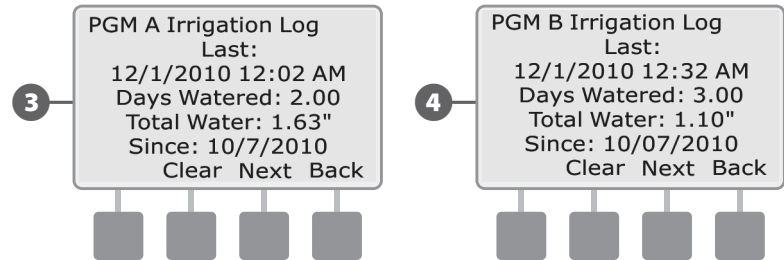

- 5 The log will reset the Last date to None, Days Watered and Total Water to 0.00, and the Since date to the current date. Press **Next** to view the next program's Irrigation Log.

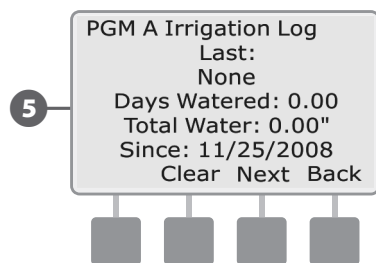

Interrupts

View the history of recent weather interrupts.

The ET Manager can cancel irrigation during rain, high winds, freezing temperatures, or a Provider Interrupt from the WSRP (see the Weather Interrupts section for more details). Interrupt History displays the last 5 interrupt events that have occurred, including the type, date and time it started, and when the interrupt cleared. When the ET Manager issues a weather interrupt, the alarm light on the ESPLXME-ET controller is illuminated.

- ▶ Turn the controller dial to ETM™/IQ™ (or ETM™/IQ™/PBC™) Settings; then press **Menu**.

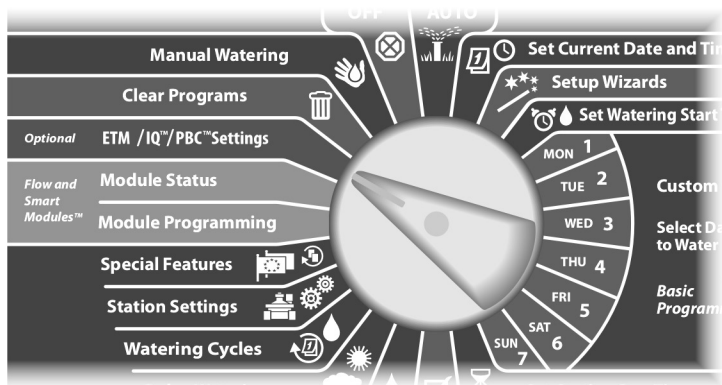

- 1 The ET Manager screen appears. Press the **2** button to select Logs.
- 2 The Logs screen appears. Press the **2** button to select Interrupts.

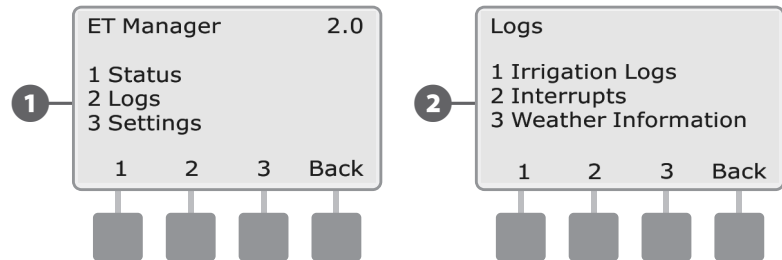

- 3 The Interrupt History screen appears. Press **Next** to view the next interrupt.

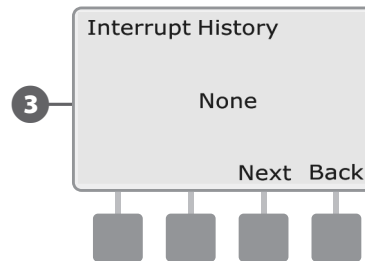

- ! **NOTE:** If no interrupt events have occurred, the Interrupt History will display "None".

Weather Information

View the latest weather information received from the local weather station.

View the latest detailed weather information received by the ET Manager Cartridge from the most recent weather signal.

- Turn the controller dial to ETM™/IQ™ (or ETM™/IQ™/PBC™) Settings; then press **Menu**.

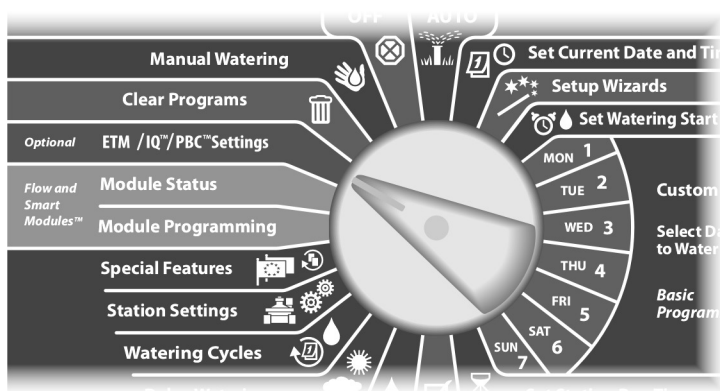

- The ET Manager screen appears. Press the **2** button to select Logs.
- The Logs screen appears. Press the **3** button to select Weather Information.

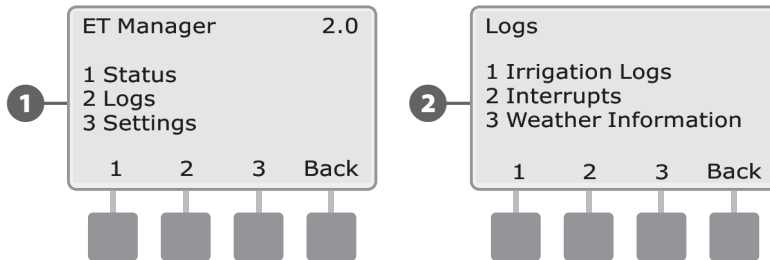

- The Weather Information screen appears. Press **More** to see more details

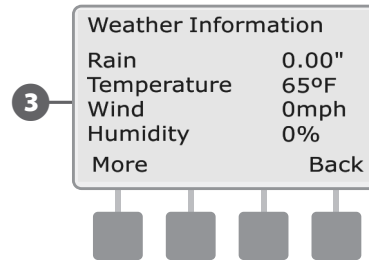

- The Rain screen appears. Press **Next** to cycle through the Rain, Temperature, Wind and Humidity weather categories

NOTE: Values displayed as being “Last Hour” are updated each time a weather signal is received. Values displayed as “High” and “Low” are the high and low values since 12:00 AM that day.

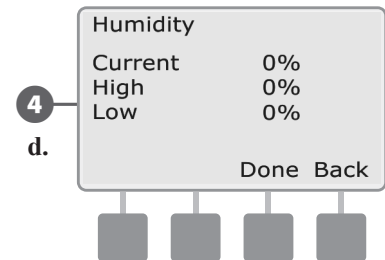
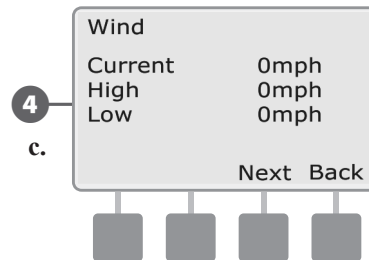
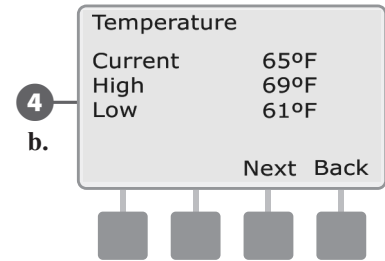
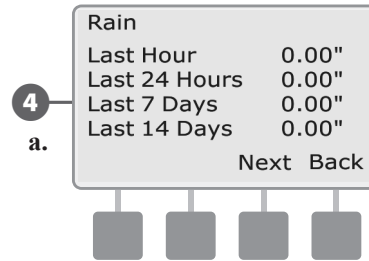

Settings Menu

Irrigation Control Menu

The Irrigation Control Menu determines how much water is used during irrigation, adjusts watering needs based on landscape type and sets watering run time limits.

Irrigation Amount

View and make adjustments to the amount of water that is used during irrigation.

The Irrigation Amount is the amount of water applied to the landscape during each program start, and is based on information about your sprinkler system and landscape.

! To determine Irrigation Amounts, refer to the ET Manager Schedule Report or see the Irrigation Amount and Station Run Times section in the Appendix.

▶ Turn the controller dial to ETM™/IQ™ (or ETM™/IQ™/PBC™) Settings; then press **Menu**.

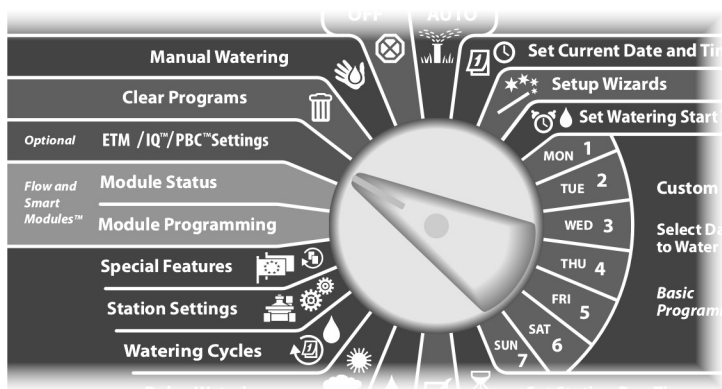

1 The ET Manager screen appears. Press the **3** button to select Settings.

2 The ET Manager Settings screen appears. Press the **1** button to select Irrigation Control.

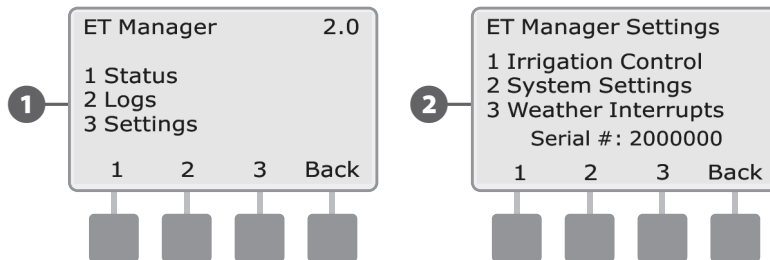

3 The Irrigation Control screen appears. Press the **1** button to select Irrigation Amount.

4 The Irrigation Amount screen appears. Press **Edit** to manually adjust the amount for Program A.

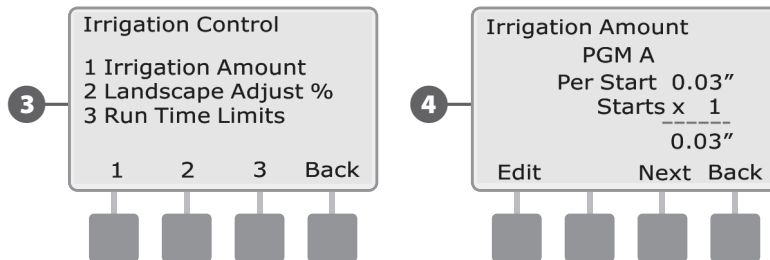

5 The Irrigation Amount Per Program Start Time screen for Program A appears. Press the **+** and **-** buttons to enter the Irrigation Amount; then press **Back**.

! **NOTE:** Programs which you do NOT want watered based on evapotranspiration (such as landscape lighting or a fountain feature) must be set to "Non ET". This is set by pressing the **-** button until 0.00 is displayed, then pressing the **-** button one more time to display "Non ET".

6 The Irrigation Amount screen appears. Press **Next** to view and edit the Irrigation Amount for Programs B, C and D.

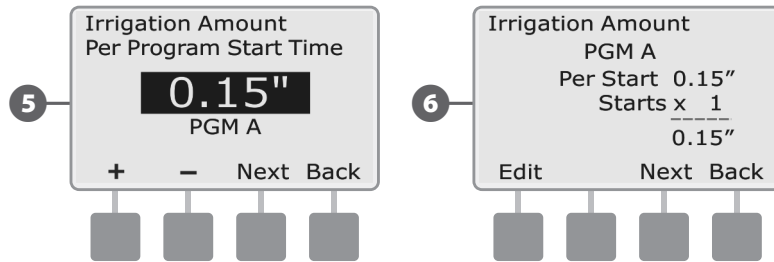

Landscape Adjust

Adjust irrigation needs according to the specific landscape type of your site.

The Landscape Adjustment percentage is used to make adjustments for site-specific landscape needs and is applied to the calculated ET. It considers the plant type, density, and local microclimate. As a general rule, the percentages should range between 60% - 100% for turf grass and 40% - 80% for shrubs.

NOTE: To determine the Landscape Adjustment percentage for your site, use the ET Manager Scheduler Software located on the ET Manager Resource CD.

Turn the controller dial to ETM™/IQ™ (or ETM™/IQ™/PBC™) Settings; then press **Menu**.

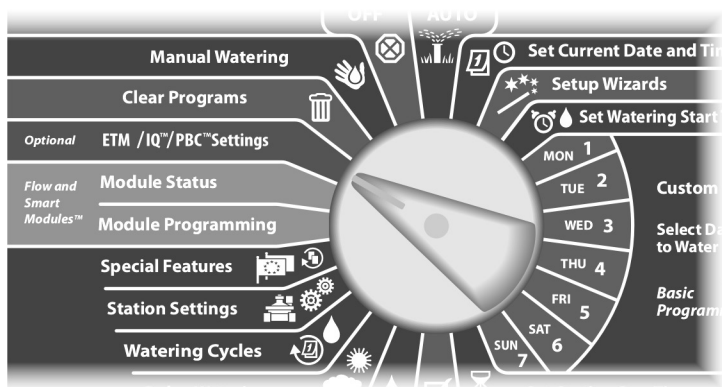

- 1 The ET Manager screen appears. Press the **3** button to select Settings.
- 2 The ET Manager Settings screen appears. Press the **1** button to select Irrigation Control.

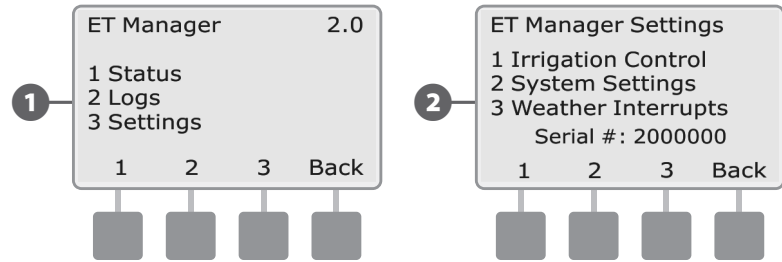

- 3 The Irrigation Control screen appears. Press the **2** button to select Landscape Adjust %.
- 4 The Landscape Adjustment screen appears. Press the **+** or **-** buttons to set the desired percentage; then press **Next** to set the next program's Landscape Adjustment Percentage.

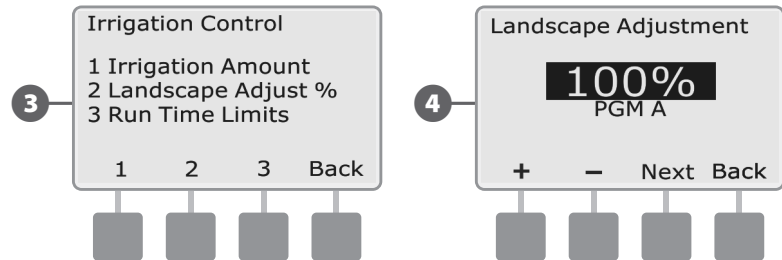

this page intentionally left blank.

Run Time Limits

Set limits on the highest and lowest Seasonal Adjust percentage the ET Manager can use.

Minimum Run Time (default 80%)

The Minimum Run Time determines the shortest watering run time that can be applied to your landscape. Setting this percentage to a low number means that the ET Manager will allow watering even if only a small amount of evaporation has occurred. Setting this percentage to a high number will delay watering until more evaporation has occurred, providing oxygen to the roots that encourages them to grow deeper, without sacrificing the health of the plant.

If watering days are limited, the ET Manager looks ahead each day to determine if watering should occur, based on the last 24 hours of evapotranspiration. If the current Moisture Level has not yet met or dropped below minimum levels, the ET Manager will ignore the Minimum Run Time limit to fill the moisture level in preparation for the upcoming day(s) that are turned off.

Maximum Run Time (default 120%)

The Maximum Run Time determines the longest watering run time that can be applied to your landscape. There may be instances where your landscape has dried out more than a regular watering cycle will be able to replace. In this case the ET Manager will adjust the Seasonal Adjust percentage above 100%, causing your irrigation system to run longer than normally scheduled. Also, the Maximum Run Time can be used to set a specific limit on watering run times.

NOTE: The ET Manager is programmed to keep your Moisture Levels at full capacity and will not set a Seasonal Adjust percentage that would cause the Moisture Level to go too high.

Run Time Limit Example

If the watering run time is set to 10 minutes, a Minimum Run Time limit of 80% means the shortest possible run time would be 8 minutes. A Maximum Run Time limit of 120% means the longest possible run time would be 12 minutes.

- 1 Turn the controller dial to ETM™/IQ™ (or ETM™/IQ™/PBC™) Settings; then press **Menu**.

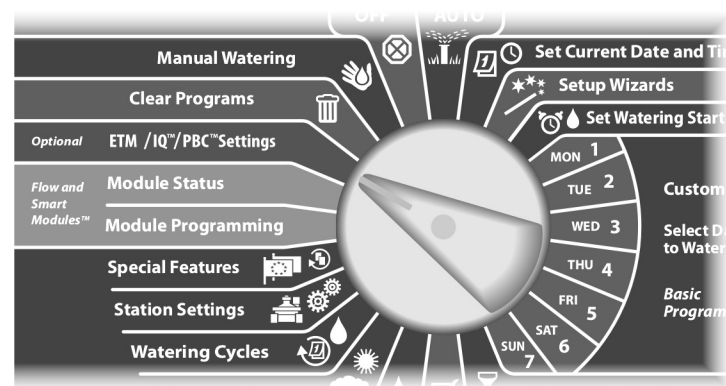

- 1 The ET Manager screen appears. Press the **3** button to select Settings.
- 2 The ET Manager Settings screen appears. Press the **1** button to select Irrigation Control.

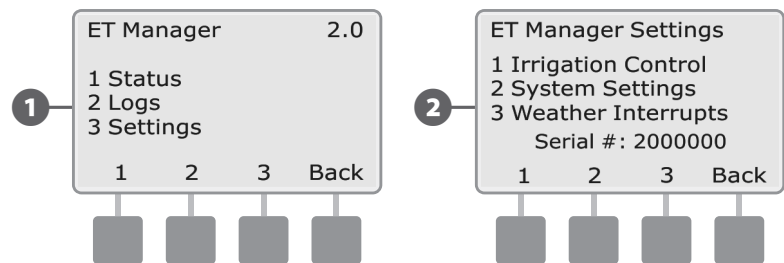

3 The Irrigation Control screen appears. Press the **3** button to select Run Time Limits.

4 The Minimum Run Time % screen appears. Press the **+** and **-** buttons to set the desired percentage; then press **Next**.

! **NOTE:** To follow best water management practices of deep, less frequent watering, set the percentage at or above 80%.

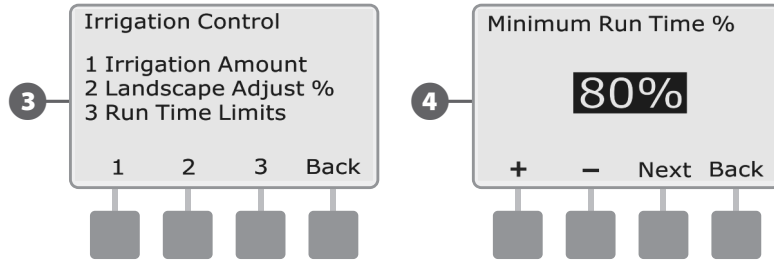

5 The Maximum Run Time % screen appears. Press the **+** and **-** buttons to set the desired percentage.

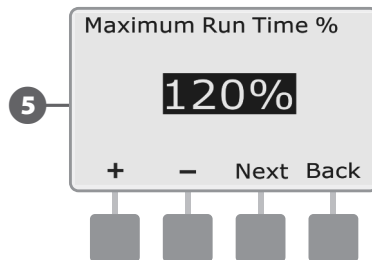

System Settings Menu

The System Settings Menu determines the source of weather data used by the ET Manager, controls system settings that affect ET values and sets historical weather data for your area.

Data Source Menu

The Data Source menu allows you to enter the Weather Region number, Rain Source, and the Signal Provider Code.

Weather Region

Assign a local weather station to your irrigation site.

The Weather Region number represents a weather station assigned by the Weather Reach™ Signal Provider (WRSP) that closely represents the location of the ESPLXME-ET Controller and irrigation site.

NOTE: To find your Weather Region number, refer to the ET Manager Schedule Report or the Weather Reach™ Signal Provider Information Sheet available at www.rainbird.com/wrsp.

Turn the controller dial to ETM™/IQ™ (or ETM™/IQ™/PBC™) Settings; then press **Menu**.

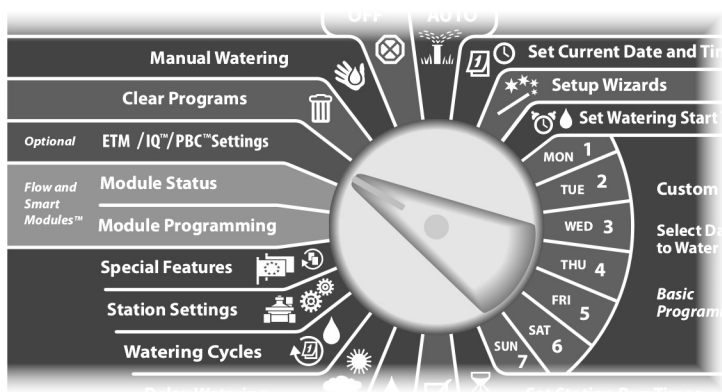

- 1 The ET Manager screen appears. Press the **3** button to select Settings.
- 2 The ET Manager Settings screen appears. Press the **2** button to select System Settings.

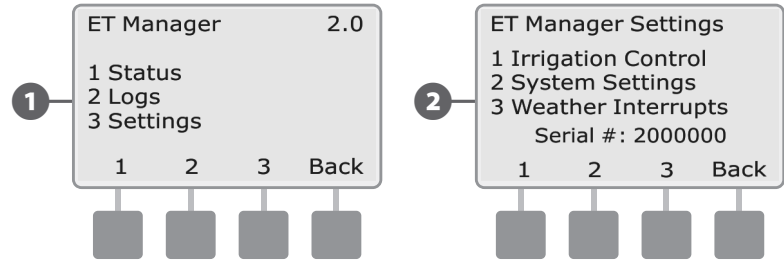

- 3 The System Settings screen appears. Press the **1** button to select Data Source.
- 4 The Data Source screen appears. Press the **1** button to select Weather Region.

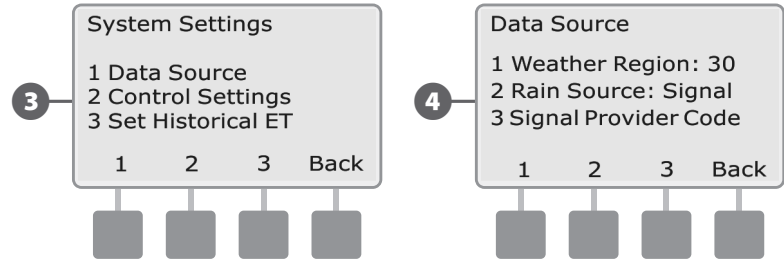

- 5 The Weather Region screen appears. Press the **+** and **-** buttons to enter the Weather Region number.

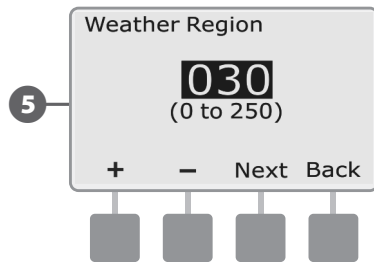

Rain Source

Select the source that the ET Manager uses for local rainfall information.

The ET Manager receives rainfall data from the hourly weather signal, an optional on-site rain gauge, or by entering the Rain Region number for your area. The preferred method is to use the weather information from the Weather Reach™ Signal Provider by setting the Rain Source to “Weather Signal”.

The ET Manager can accept actual rainfall input from both 1mm/tip (ETM – RG) and 0.01”/tip (RAINGAUGE) rain gauges. These two gauges connect to the ESPLXME-ET controller in the same way. See the Rain Gauge Installation section for more information.

Similar to the Weather Region number, a Rain Region number corresponds to a local rain station that tracks local rainfall, and is also accessed by the Weather Reach™ Signal Provider.

! **NOTE:** To determine if a Rain Region is available in your area, refer to the Weather Reach™ Signal Provider Information Sheet available at www.rainbird.com/wrsp.

Weather Signal

Turn the controller dial to ETM™/IQ™ (or ETM™/IQ™/PBC™) Settings; then press **Menu**.

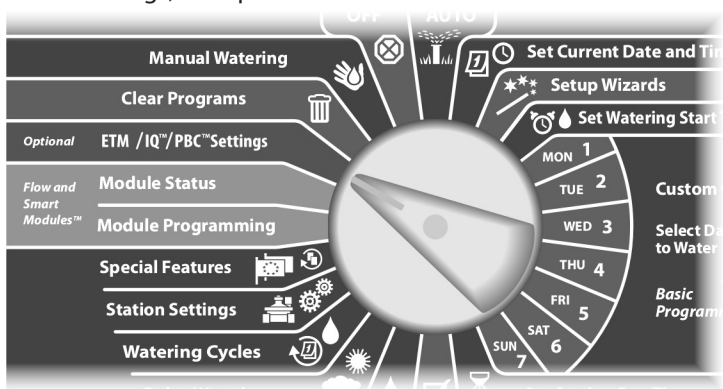

- 1 The ET Manager screen appears. Press the **3** button to select Settings.
- 2 The ET Manager Settings screen appears. Press the **2** button to select System Settings.

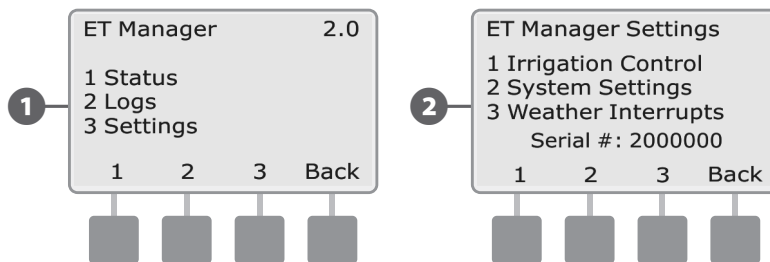

- 3 The System Settings screen appears. Press the **1** button to select Data Source.
- 4 The Data Source screen appears. Press the **2** button to select Rain Source.

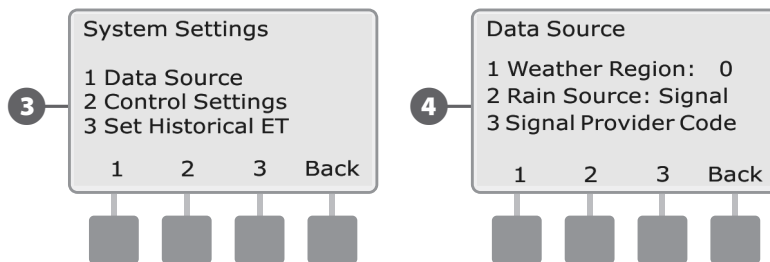

- 5 The Rain Source screen appears. Press the **+** and **-** buttons until Weather Signal is selected.

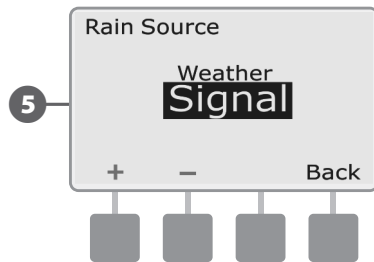

Local Rain Gauge

- Turn the controller dial to ETM™/IQ™ (or ETM™/IQ™/PBC™) Settings; then press **Menu**.

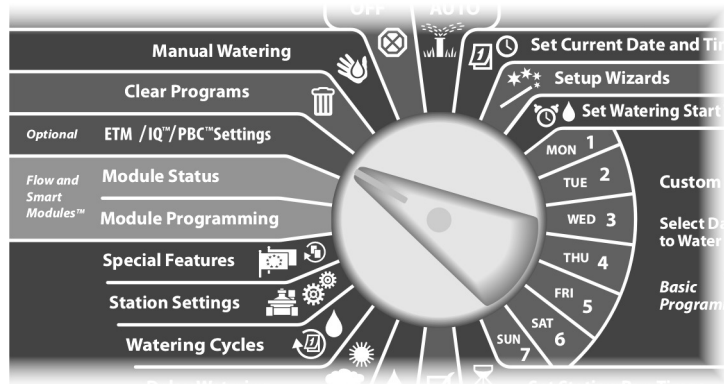

- The ET Manager screen appears. Press the **3** button to select Settings.
- The ET Manager Settings screen appears. Press the **2** button to select System Settings.

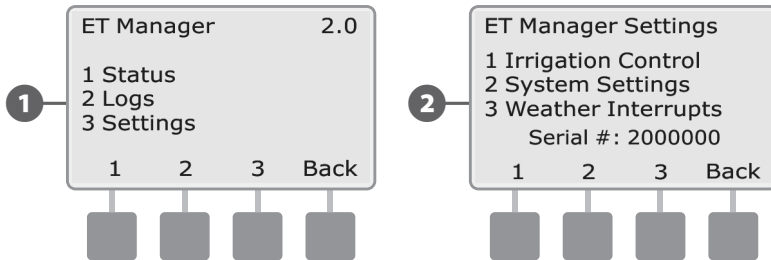

- The System Setting screen appears. Press the **1** button to select Data Source.
- The Data Source screen appears. Press the **2** button to select Rain Source.

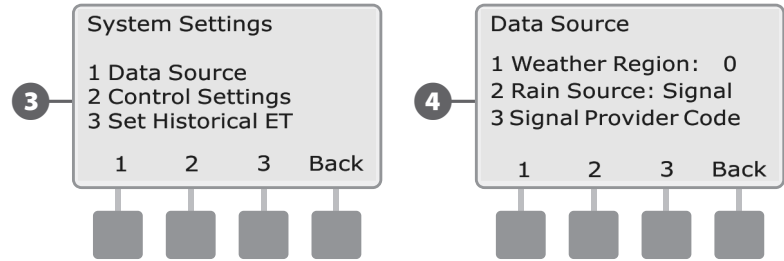

- The Rain Source screen appears. Press the **+ and -** buttons until Local Gauge is selected; then press **More**.
- Press the **+ and -** buttons to select your type of rain gauge, "ETM-RG" or "0.01" / Tip".

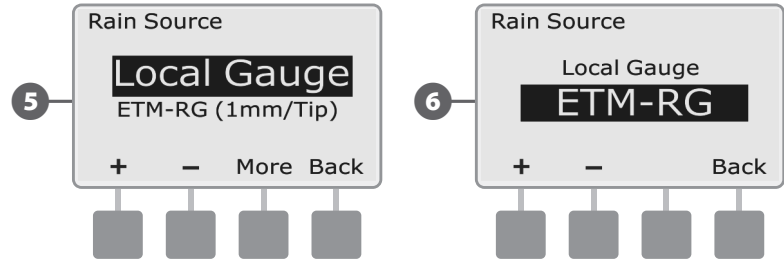

Rain Region

- Turn the controller dial to ETM™/IQ™ (or ETM™/IQ™/PBC™) Settings; then press **Menu**.

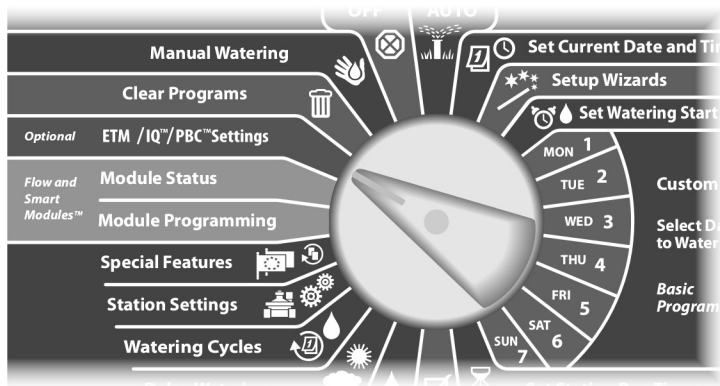

- The ET Manager screen appears. Press the **3** button to select Settings.
- The ET Manager Settings screen appears. Press the **2** button to select System Settings.

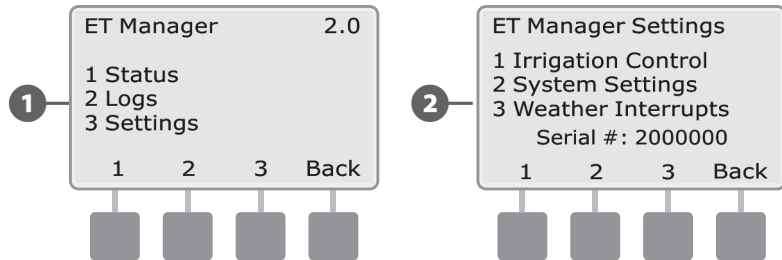

- The System Setting screen appears. Press the **1** button to select Data Source.
- The Data Source screen appears. Press the **2** button to select Rain Source.

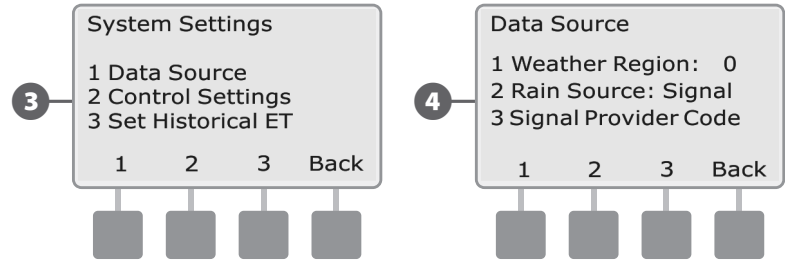

- The Rain Source screen appears. Press the **+ and -** buttons until Rain Region is selected; then press **Edit**.
- Press the **+ or -** to select the Rain Region number for your area.

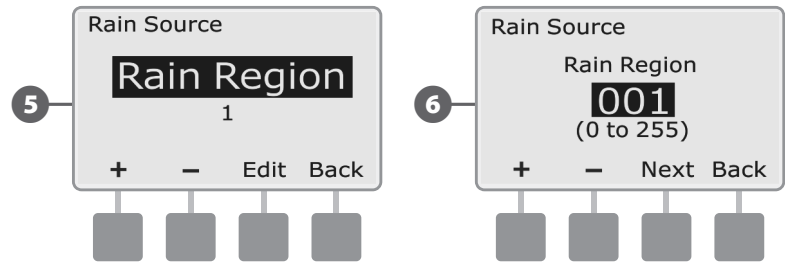

Signal Provider Code

Enter the code that is required to receive weather information from the WSRP.

The ET Manager must be programmed to receive information from your local Weather Reach™ Signal Provider (WRSP). A Signal Provider Code is unique for each WRSP and is necessary for an ET Manager Cartridge to receive a weather signal. The code consists of 10 different numbers labeled A thru J.

NOTE: To determine your Signal Provider Code, refer to the ET Manager Schedule Report or the Weather Reach™ Signal Provider Information Sheet available at www.rainbird.com/wrsp.

Turn the controller dial to ETM™/IQ™ (or ETM™/IQ™/PBC™) Settings; then press **Menu**.

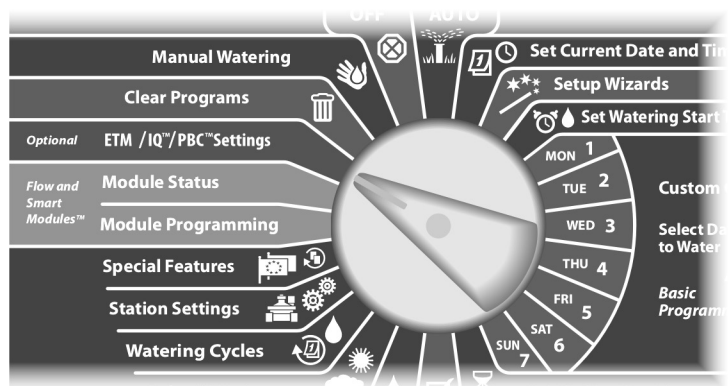

- 1 The ET Manager screen appears. Press the **3** button to select Settings.
- 2 The ET Manager Settings screen appears. Press the **2** button to select System Settings.

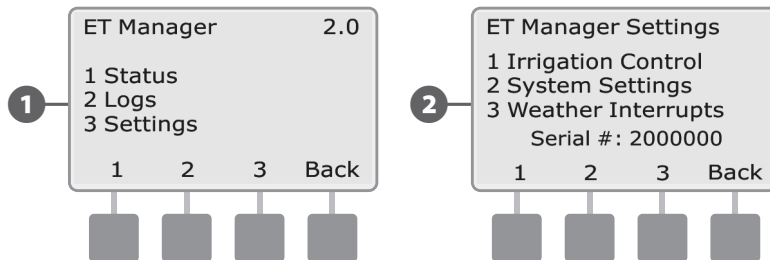

- 3 The System Setting screen appears. Press the **1** button to select Data Source.
- 4 The Data Source screen appears. Press the **3** button to select Signal Provider Code.

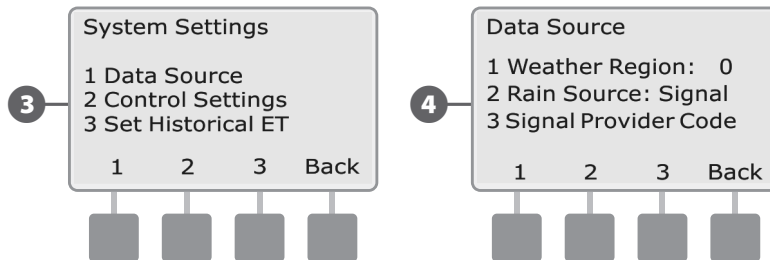

- 5 The Signal Provider Code screen appears. Press **Edit** to enter or update the code.
- 6 Press the **+ and -** buttons to enter the value for A; then press **Next** to move to the next letter. When the value for every letter is entered, press **Done**.

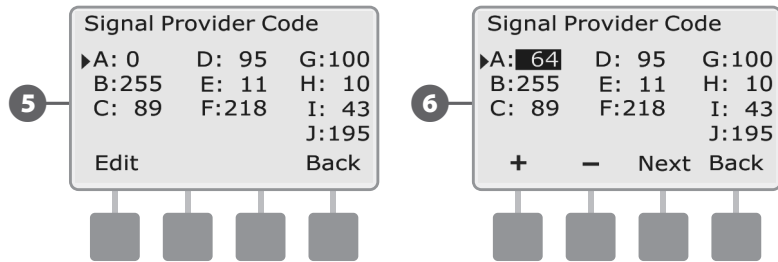

Control Settings Menu

The Control Settings Menu allows you to set Effective Rain values, ET Settings and Options.

Effective Rain

Set limits on the amount of rain recognized by the ET Manager to account for excessive rainfall.

Effective rain is the actual amount of rainfall that is available to the landscape. When rainfall amounts and intensities are extreme, not all rainfall will stay within the root zone. To restrict the amount of rain recognized by the ET Manager, two effective rainfall limits should be programmed - Maximum Hourly Rain and Saturation Allowance.

Maximum Hourly Rain

The Maximum Hourly Rain is the maximum amount of rain that will be used in an hour to adjust the soil moisture level.

Saturation Allowance

The Saturation Allowance is the amount of rain it takes to saturate the soil after satisfying the total irrigation amount before run-off occurs. Saturation Allowance settings can be made for each individual program (depending on plant type) and are typically programmed as half the total irrigation amount.

▶ Turn the controller dial to ETM™/IQ™ (or ETM™/IQ™/PBC™) Settings; then press **Menu**.

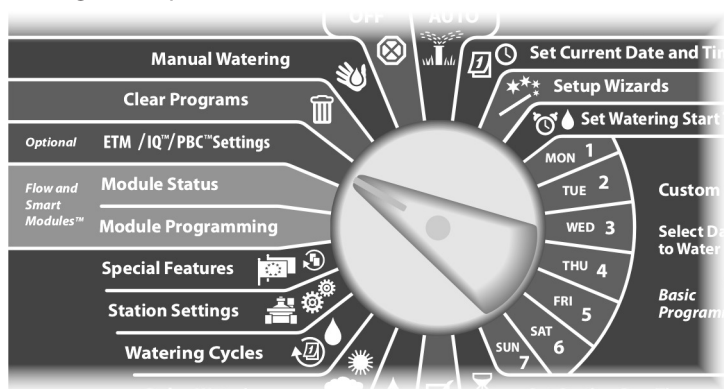

- 1 The ET Manager screen appears. Press the **3** button to select Settings.
- 2 The ET Manager Settings screen appears. Press the **2** button to select System Settings.

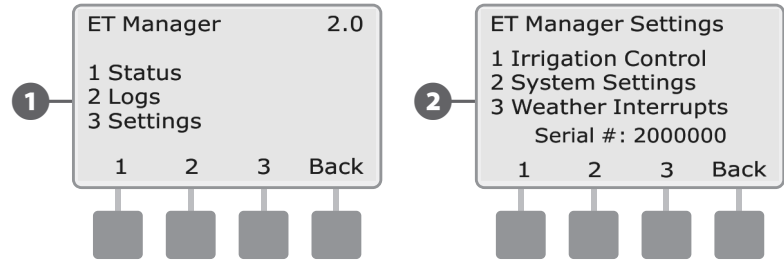

- 3 The System Setting screen appears. Press the **2** button to select Control Settings.
- 4 The Control Settings screen appears. Press the **1** button to select Effective Rain.

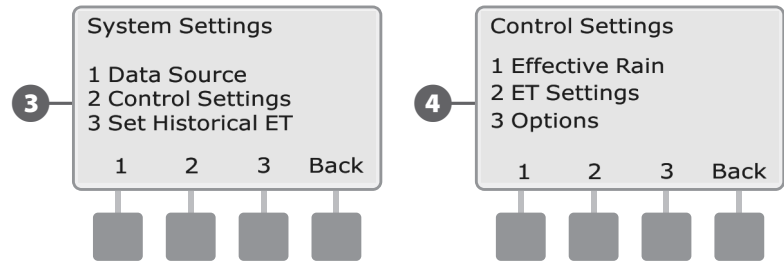

- 5 The Effective Rain screen appears. Press the **+** and **-** buttons to adjust the Maximum Hourly Rain setting; then press **Next**.
- 6 The Saturation Allowance for PGM A appears. Press the **+** and **-** buttons to adjust the setting; then press **Next** to view and adjust the next program.

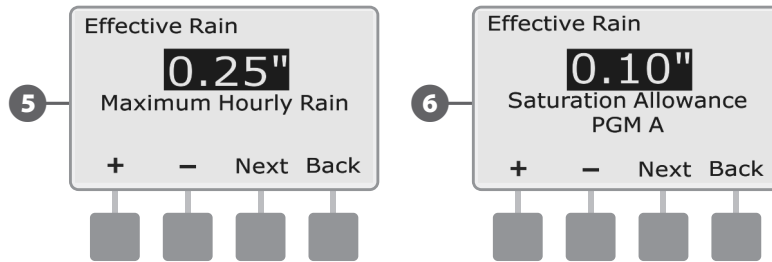

ET Settings Menu

The ET Settings Menu allows you to select the ET Source, enter site Elevation and adjust for Wind.

ET Source

Select the source that the ET Manager uses for local weather information.

The ET Manager can be set to use either the hourly weather signal from the WSRP or historical ET data for your irrigation site. The default setting is Signal.

NOTE: Historical ET data is available on the ET Manager Schedule Report or the Weather Reach™ Signal Provider Information Sheet at www.rainbird.com/wrsp.

Turn the controller dial to ETM™/IQ™ (or ETM™/IQ™/PBC™) Settings; then press **Menu**.

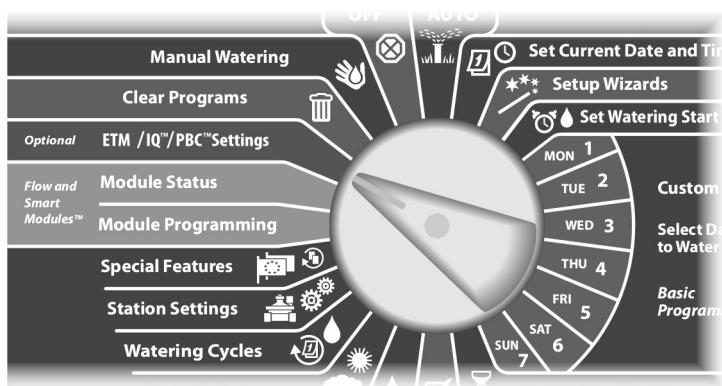

- 1 The ET Manager screen appears. Press the **3** button to select Settings.
- 2 The ET Manager Settings screen appears. Press the **2** button to select System Settings.

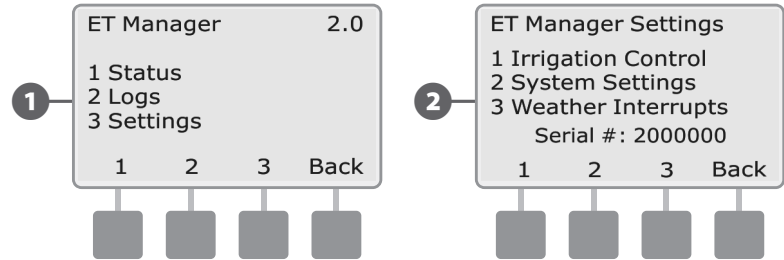

- 3 The System Setting screen appears. Press the **2** button to select Control Settings.
- 4 The Control Settings screen appears. Press the **2** button to select ET Settings.

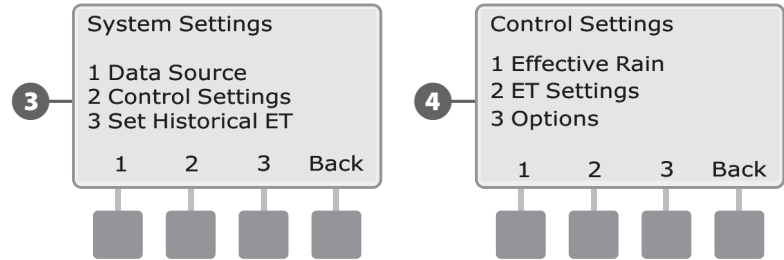

- 5 The ET Settings screen appears. Press the 1 button to select ET Source.
 - 6 The ET Source screen appears. Press the **+** and **-** buttons to select Signal or Historical.
- !** **NOTE:** When the ET Manager Cartridge is set to Historical, “H-ET” will be displayed in the upper right corner of the Moisture Levels screen as a reminder that the ET Manager is set to Historical ET.

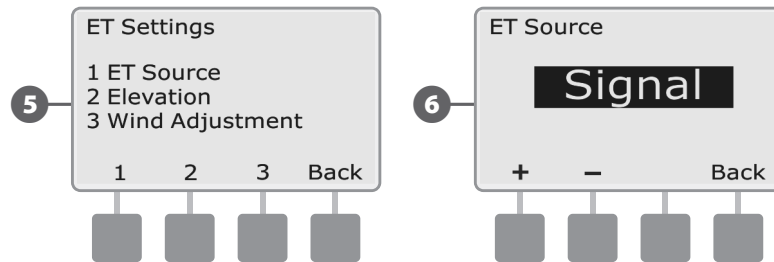

Elevation

Enter the approximate elevation of your irrigation site.

In order to calculate accurate evapotranspiration values for your location, the approximate elevation your the irrigation site is required.

! **NOTE:** To determine the elevation, refer to the ET Manager Schedule Report or the Weather Reach™ Signal Provider Information Sheet available at www.rainbird.com/wrsp.

☰ Turn the controller dial to ETM™/IQ™ (or ETM™/IQ™/PBC™) Settings; then press **Menu**.

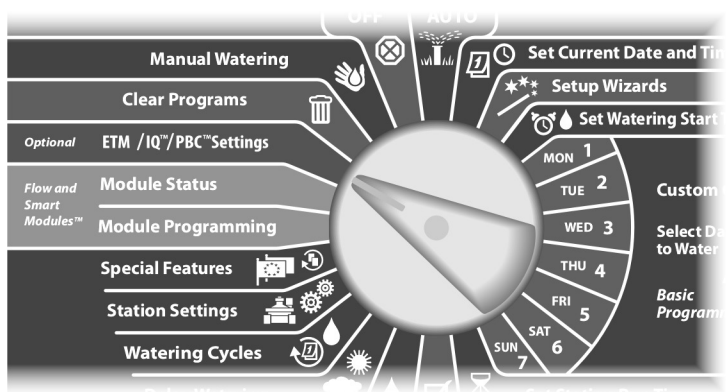

1 The ET Manager screen appears. Press the **3** button to select Settings.

2 The ET Manager Settings screen appears. Press the **2** button to select System Settings.

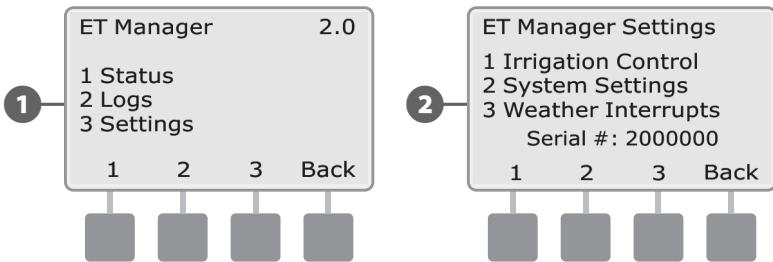

3 The System Setting screen appears. Press the **2** button to select Control Settings.

4 The Control Settings screen appears. Press the **2** button to select ET Settings.

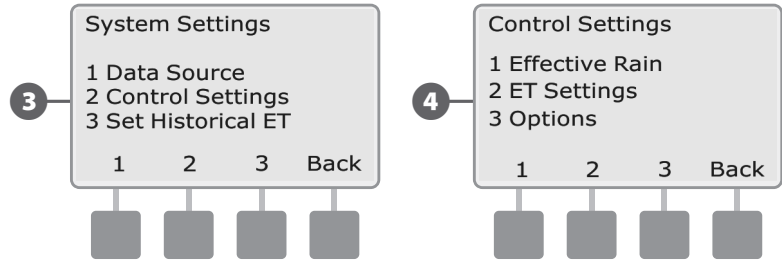

5 The ET Settings screen appears. Press the **2** button to select Elevation.

6 The Elevation screen appears. Press the **+** and **-** buttons to enter the elevation for the irrigation site.

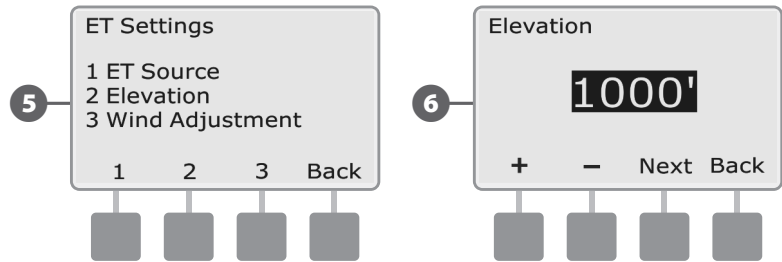

this page intentionally left blank.

Wind Adjustment

Adjust wind speed measurements to account for local weather variations.

The Wind Speed measurement included in the weather signal can be scaled by a percentage to compensate for variations in local weather conditions. When this setting is 100%, the ET Manager will use the exact wind measurement as it is received in the hourly weather broadcast.

NOTE: This is necessary ONLY if your signal is broadcast from a weather station where the wind speed measurements are consistently different from your irrigation site.

Turn the controller dial to ETM™/IQ™ (or ETM™/IQ™/PBC™) Settings; then press **Menu**.

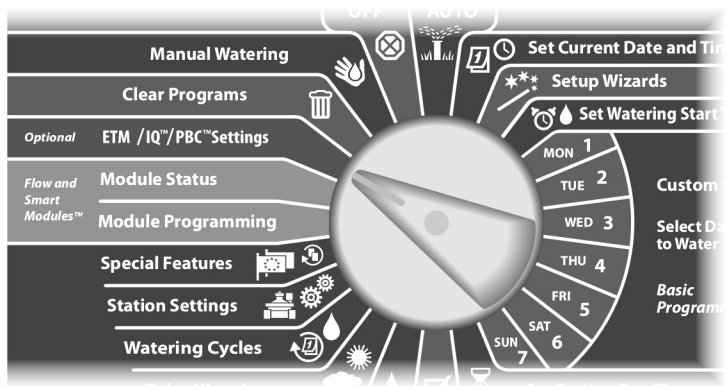

- 1 The ET Manager screen appears. Press the **3** button to select Settings.
- 2 The ET Manager Settings screen appears. Press the **2** button to select System Settings.

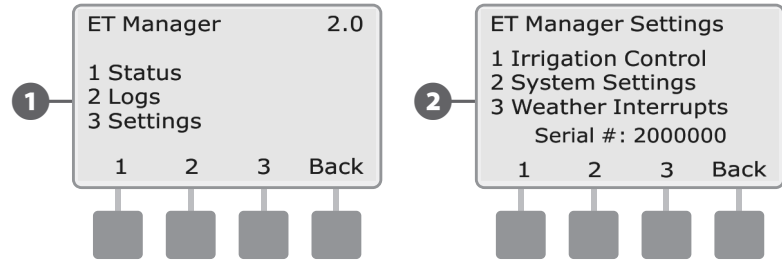

- 3 The System Setting screen appears. Press the **2** button to select Control Settings.
- 4 The Control Settings screen appears. Press the **2** button to select ET Settings.

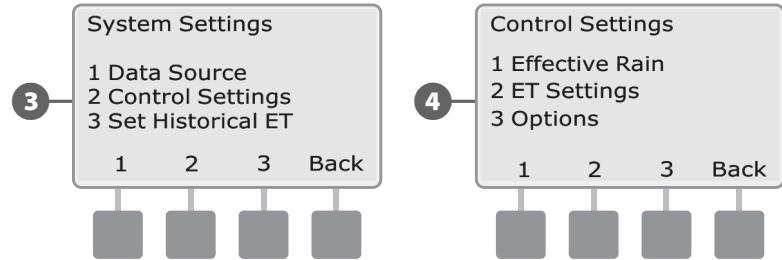

- 5 The ET Settings screen appears. Press the **3** button to select Wind Adjustment.
- 6 The Wind Adjustment screen appears. Press the **+** **and** **-** buttons to set the desired percentage.

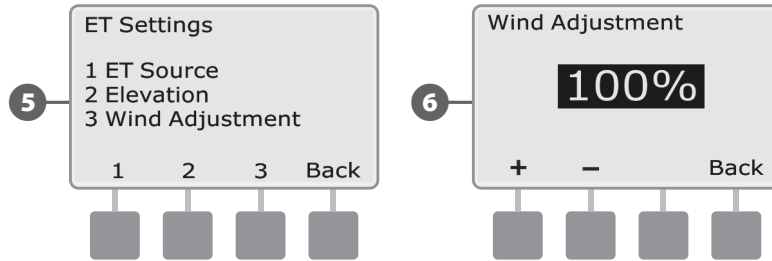

Options Menu

The Options Menu allows you to select the desired Units for display, enter Signal Kc values and Clear Data.

Units

Select English or Metric for display values.

The ET Manager can calculate and display values in either English or Metric units.

- Turn the controller dial to ETM™/IQ™ (or ETM™/IQ™/PBC™) Settings; then press **Menu**.

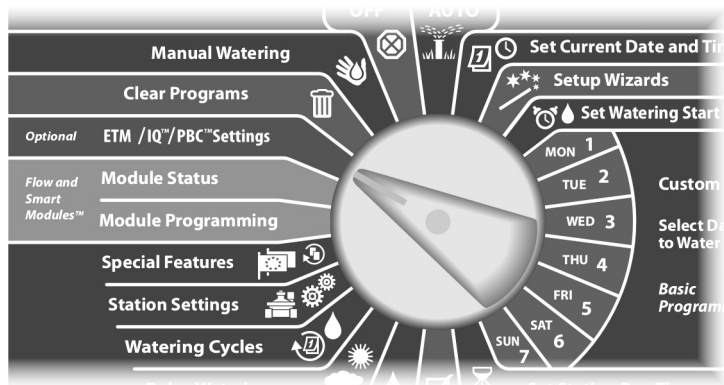

- The ET Manager screen appears. Press the **3** button to select Settings.
- The ET Manager Settings screen appears. Press the **2** button to select System Settings.

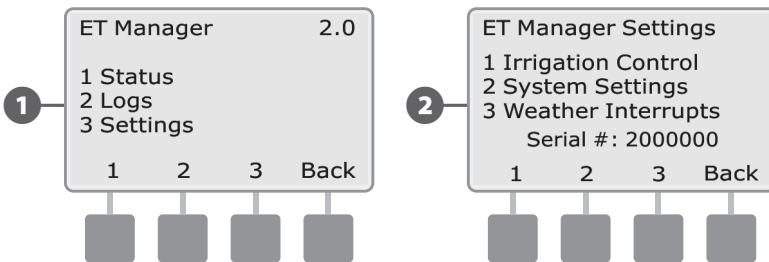

- The System Setting screen appears. Press the **2** button to select Control Settings.
- The Control Settings screen appears. Press the **3** button to select Options.

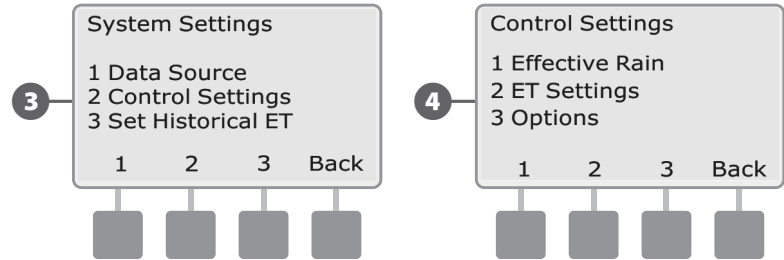

- The Options screen appears. Press the **1** button to select Units.
- The Units screen appears. Press the **+ and -** buttons to select English or Metric.

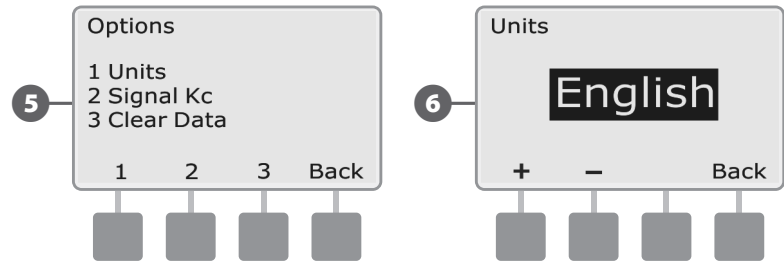

this page intentionally left blank.

Signal Kc

Adjust ET values based on specific crop types.

The Weather Reach™ Signal Provider may broadcast a Signal Kc (or Signal Crop Coefficient) value, used by the ET Manager to make adjustments based a specific crop. This value can vary over the course of the year due to seasonal conditions.

NOTE: Contact your Weather Reach™ Signal Provider for information regarding the broadcast crop coefficient. To find your Weather Reach™ Signal Provider, visit www.rainbird.com/wrsp or contact your Rain Bird Distributor.

Turn the controller dial to ETM™/IQ™ (or ETM™/IQ™/PBC™) Settings; then press **Menu**.

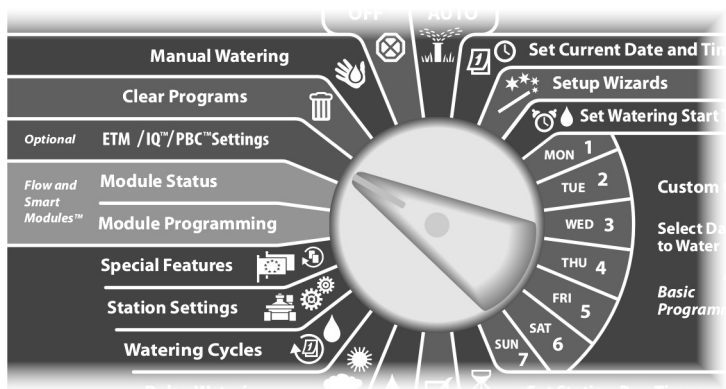

1 The ET Manager screen appears. Press the **3** button to select Settings.

2 The ET Manager Settings screen appears. Press the **2** button to select System Settings.

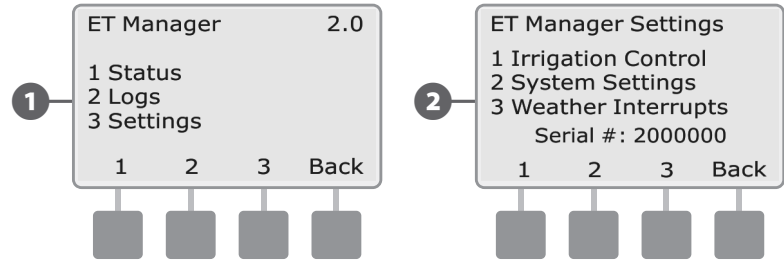

3 The System Setting screen appears. Press the **2** button to select Control Settings.

4 The Control Settings screen appears. Press the **3** button to select Options.

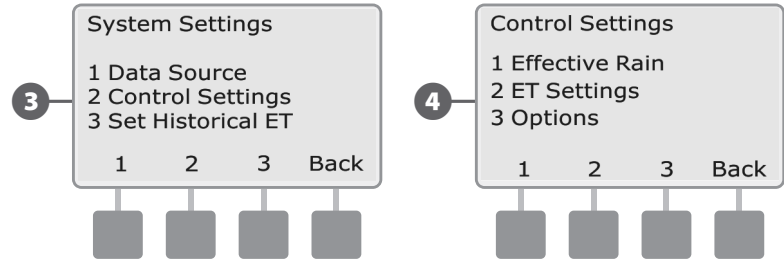

- 5 The Options screen appears. Press the **2** button to select Signal Kc.
- 6 The Signal Kc screen appears. Press the **+ and -** buttons to select Use or Ignore.

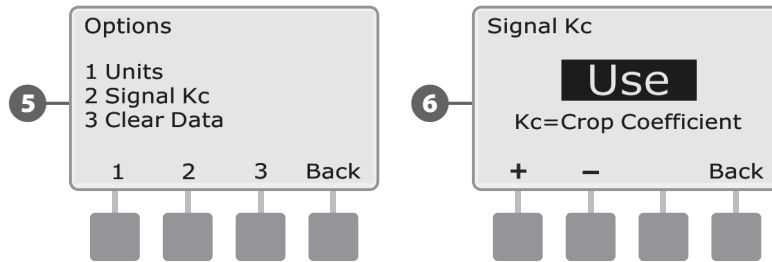

Clear Data

Clear data and history without changing any system settings.

If necessary, you may clear all records stored in the ET Manager. Clearing data will not change any settings, but will erase all weather information, paging history, interrupt history and irrigation logs. Moisture Levels will reset to 0, which allows the next watering cycle to start.

- 1 Turn the controller dial to ETM™/IQ™ (or ETM™/IQ™/PBC™) Settings; then press **Menu**.

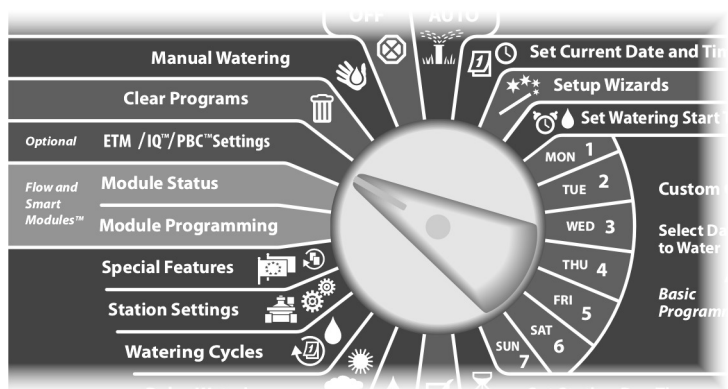

- 1 The ET Manager screen appears. Press the **3** button to select Settings.
- 2 The ET Manager Settings screen appears. Press the **2** button to select System Settings.

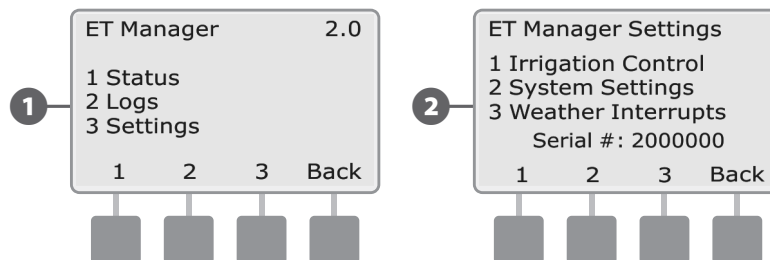

- 3 The System Setting screen appears. Press the **2** button to select Control Settings.
- 4 The Control Settings screen appears. Press the **3** button to select Options.

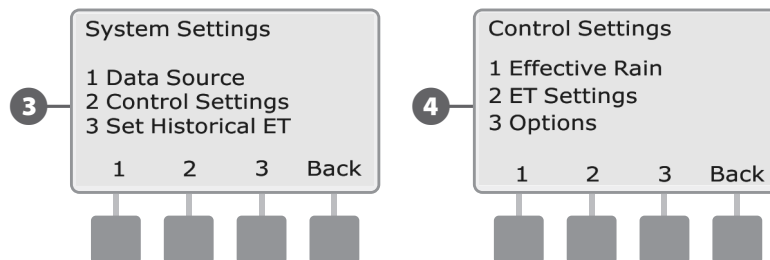

- 5 The Options screen appears. Press the **3** button to select Clear Data.
- 6 The Clear Data screen appears. A message is displayed asking if you want to clear all data. Press **Yes** to clear data.

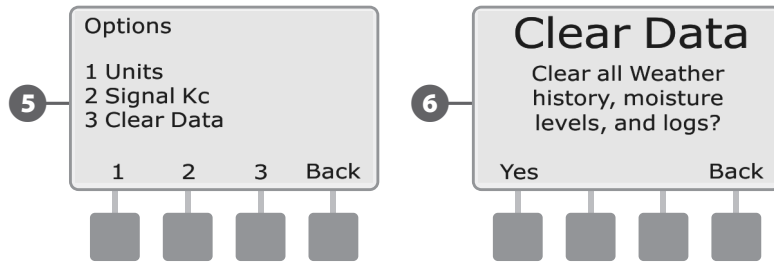

- 7 A "Clearing Data, Please Wait" message appears while the data is cleared.
 - 8 Once the data has cleared, "Data Cleared" is displayed.
- !** **NOTE:** Clearing data will NOT make an Alert Message clear. See the Alert Messages section for more details.

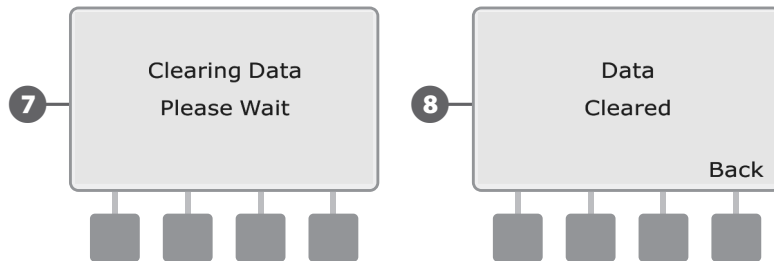

Set Historical ET

Enter local historical weather data to use if there is no signal from the weather station.

Historical ET represents an average daily ET value for your area. Historical ET data is used if the ET Source is set to "Historical", in the event of a power outage, or as a backup to paging signal interference. The ET Manager will continue to operate with historical data if there is no signal from the weather station.

NOTE: To determine Historical ET data, refer to the ET Manager Schedule Report or the Weather Reach™ Signal Provider Information Sheet available at www.rainbird.com/wrsp.

Turn the controller dial to ETM™/IQ™ (or ETM™/IQ™/PBC™) Settings; then press **Menu**.

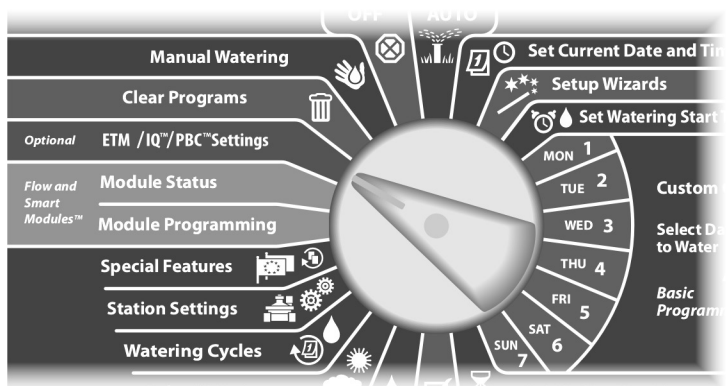

- 1 The ET Manager screen appears. Press the **3** button to select Settings.
- 2 The ET Manager Settings screen appears. Press the **2** button to select System Settings.

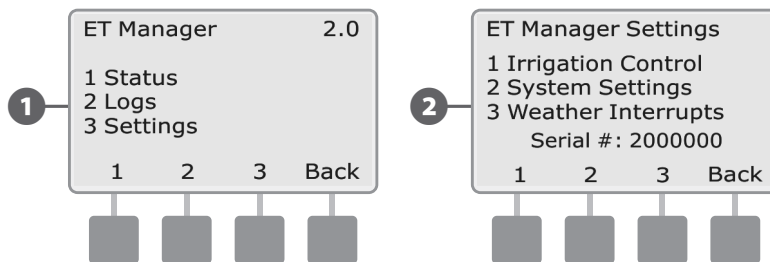

- 3 The System Setting screen appears. Press the **3** button to select Set Historical ET.
- 4 The Average Daily Historical ET screen appears. Press the **+** and **-** buttons to enter the daily Historical ET average for January; then press **Next** to move to the next month. When the ET average for every month is entered, press **Done**.

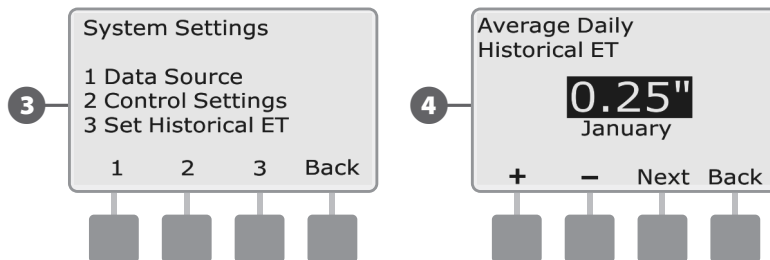

this page intentionally left blank.

Weather Interrupts

Automatically cancel watering due to adverse weather conditions.

The ET Manager can automatically cancel watering should unfavorable weather conditions arise. You decide how much rainfall or wind is required or how cold it must be to cancel watering. An Alert message is displayed whenever a Weather Interrupt cancels watering.

NOTE: Once the default settings have been changed, they are not able to be automatically reset by the ESPLXME-ET Controller.

Rain Interrupt

If rainfall over the last hour exceeds the 1 Hour Rain Interrupt setting, watering is canceled. Once the total rainfall in the last hour drops below the 1 Hour Rain Interrupt setting, the 1 Hour Rain Interrupt will clear.

If rainfall over the last 24 hours exceeds the 24 Hour Rain Interrupt setting, watering is canceled. Once the total rainfall in the last 24 hours drops below the 24 Hour Rain Interrupt setting, the 24 Hour Rain Interrupt will clear.

Temperature Interrupt

If the air temperature received by the hourly weather signal is less than the Temperature Interrupt setting, watering is canceled. Once the air temperature rises above the interrupt setting, the Temperature Interrupt will clear.

Wind Interrupt

If the wind speed received by the hourly weather signal exceeds the Wind Interrupt setting, watering is canceled. Once the wind speed decreases below the interrupt setting, the Wind Interrupt will clear.

Provider Interrupt

The Weather Reach™ Signal Provider (WRSP) can send a signal to cancel watering. This may be necessary during an emergency condition in the community to limit the demand on the community water system. As a service, your WRSP may also watch weather forecasts and choose to interrupt watering for expected conditions such as large rain storms. A Provider Interrupt lasts for 24 hours. For information regarding a current Provider Interrupt, contact your Weather Reach™ Signal Provider.

Turn the controller dial to ETM™/IQ™ (or ETM™/IQ™/PBC™) Settings; then press **Menu**.

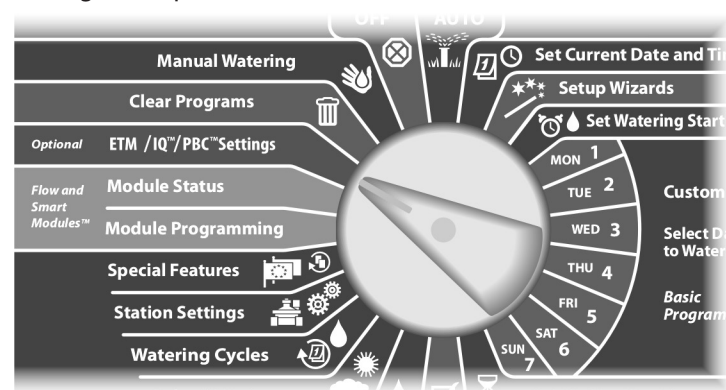

- 1 The ET Manager screen appears. Press the **3** button to select Settings.
- 2 The ET Manager Settings screen appears. Press the **3** button to select Weather Interrupts.

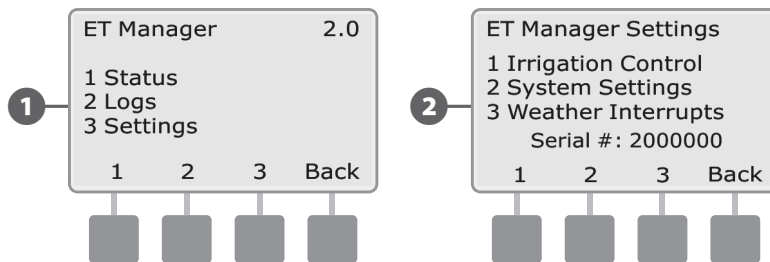

- 3 The Weather Interrupts screen appears. Press the **1** button to select Rain.
- 4 The Rain Interrupt screen appears. Press the **+ and -** buttons to set the rain amount for the 1 Hour Rain Interrupt; then press **Next**.

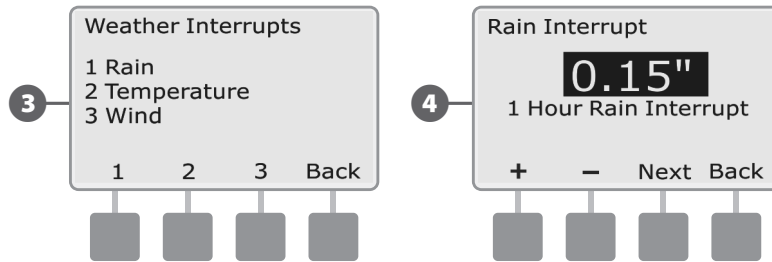

- 5 Press the **+ and -** buttons to set the rain amount for the 24 Hour Rain Interrupt; then press **Done**.

! **NOTE:** When a Rain Interrupt occurs the current watering is canceled. The next watering cycle will start when the moisture level has depleted enough to require an irrigation. This may take several days.

- 6 The Weather Interrupts screen appears. Press the **2** button to select Temperature.

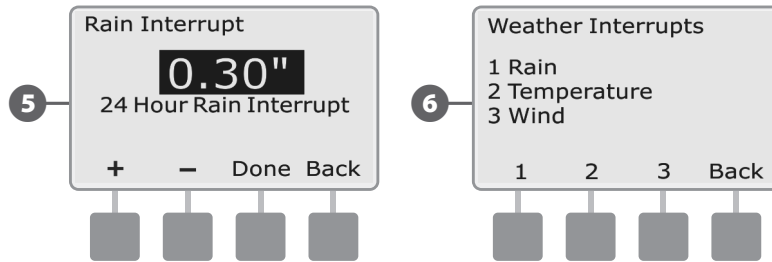

- 7 The Temperature Interrupt screen appears. Press the **+ and -** buttons to set the desired temperature; then press **Back**.
- 8 The Weather Interrupts screen appears. Press the **3** button to select Wind.

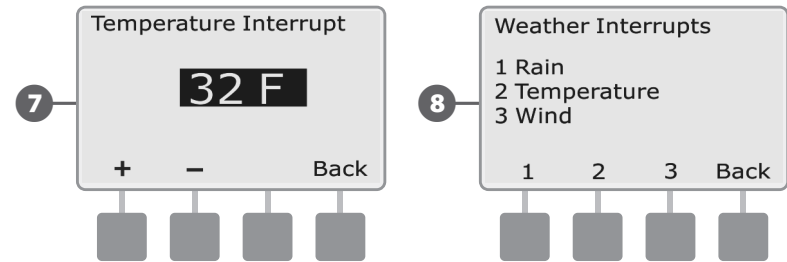

- 9 The Wind Interrupt screen appears. Press the **+ and -** buttons to set the desired wind speed.

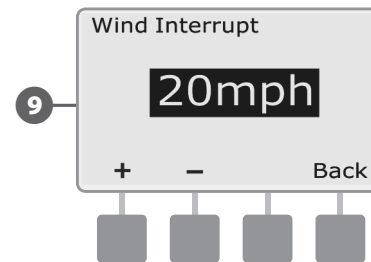

Manual Watering

If you need manually run a program or individual station, see the Manual Watering section found in the Auxiliary Operation section of your ESPLXME-ET Controller Installation, Programming, & Operation Guide.

Manual Watering will automatically set the Seasonal Adjust percentage to 100%. Prior to the next scheduled start time, the ET Manager will change the Seasonal Adjust percentage back to the proper adjusted value to reflect the current Moisture Level.

 **NOTE:** Manual Watering is NOT tracked by the ET Manager. The ET Manager will calculate watering needs as if the manual watering had not occurred.

Backup and Recall Programs

To backup and recall programs for later use, see the Backup and Recall Programs section found in the Options & Special Features section of your ESPLXME-ET Controller Installation, Programming, & Operation Guide.

 **NOTE:** The ESPLXME-ET Controller will backup and recall programs for both the ESPLXME-ET Controller AND the ET Manager Cartridge.

Section E - Flow Management

The ESPLXME-ET controller offers several tools to dynamically manage the hydraulics of the irrigation system including:

FloManager™

Standard feature of the LXME controller which manages flow demands on the water source.

FloWatch™

Optional add-in module which monitors the actual flow rate of the system and reacts to flow problems.

Set Flow Units

To use FloManager or FloWatch you first need to set the measurement units for flow management.

- Turn the controller dial to Special Features.

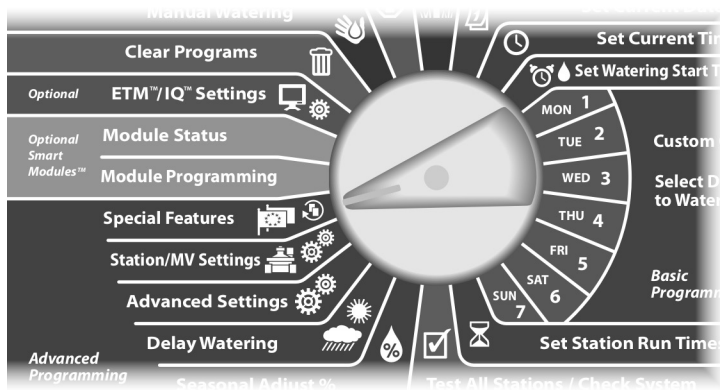

- The Special Features screen appears. Press the Down Arrow button to select Set Flow Units; then press Next.
- The Flow Units screen appears. Press the + and – buttons to select the desired flow measurement (English or metric); then press Next.

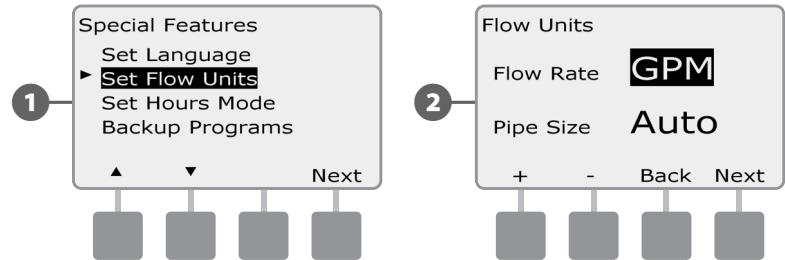

- Press the + and – buttons to select the desired pipe size measurement (English or metric).

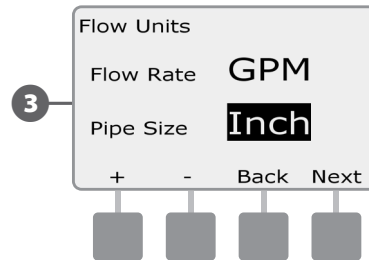

FloManager™ Overview

FloManager is a standard feature of the ESPLXME-ET controller which manages flow demands on the water source and can be used with or without an actual flow sensor.

Managers of larger irrigation systems can struggle to find enough hours per week to irrigate the site. This issue is more prevalent today with mandated restrictions on the number of irrigation days per week and hours per day. Operating your irrigation system at the most efficient flow rate has several advantages:

- Decreases the overall time required to irrigate the site
- Manages the flow and pressure delivered to each valve
- Saves power for systems with pumps

If the irrigation system water source can support the operation of multiple stations simultaneously, FloManager can provide automated hydraulic management, optimizing the available water.

FloManager, working with the station priority and SimulStation settings, will dynamically select combinations of stations to operate simultaneously in order to utilize as much of the available water from the water source as possible. Each station will still operate for the programmed run time and the maximum capacity of the water source will never be exceeded.

FloManager™ Requirements

FloManager will require the following information:

- FloManager Flow Rate. This is the maximum capacity of the irrigation system water source (water meter or pump).
- Station Flow Rates. If you do not have a flow sensor, you can enter the station flow rates manually.

! **NOTE:** If the optional Flow Smart Module and flow sensor are installed, the station flow rates required for FloManager can be calculated automatically. Refer to FloWatch Operation for instructions on using the Learn Flow Utility.

Set Up and Use FloManager™

Enable (Or Disable) FloManager™

- 1 Turn the controller dial to Advanced Settings.

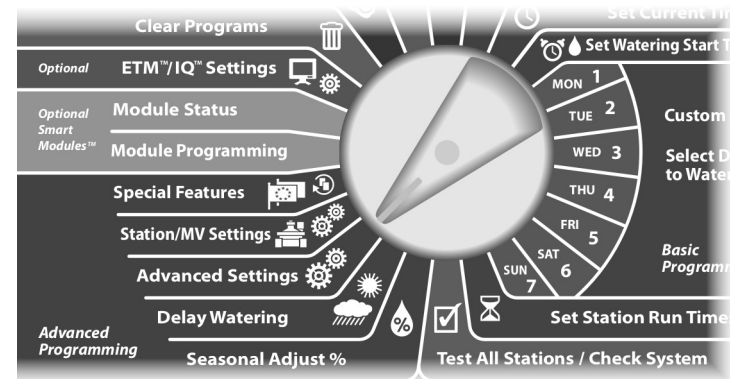

- 1 The Advanced Settings screen appears. Use the Down Arrow to select FloManager; then press Next.
- 2 The FloManager screen appears with FloManager On/Off selected; press Next.

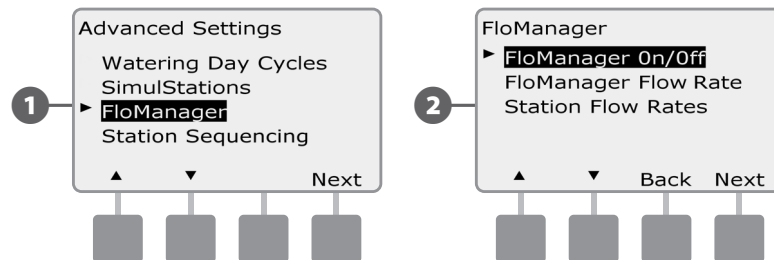

- 3 Press the On button to enable FloManager, or press Off to disable.
- 4 If Station Sequencing was previously set to Station Numbers, then turning FloManager ON will automatically change the setting to Station Priorities. Press Accept to make the change or else press Reject. See Section D, Advanced Programming, Station Sequencing for more details.

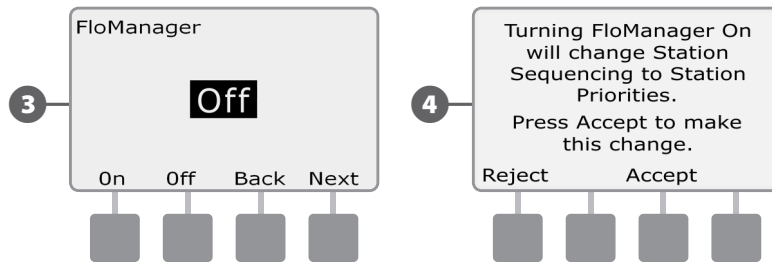

Set FloManager™ Flow Rate

FloManager needs to know the maximum capacity of the irrigation system water source.

- Turn the controller dial to Advanced Settings.

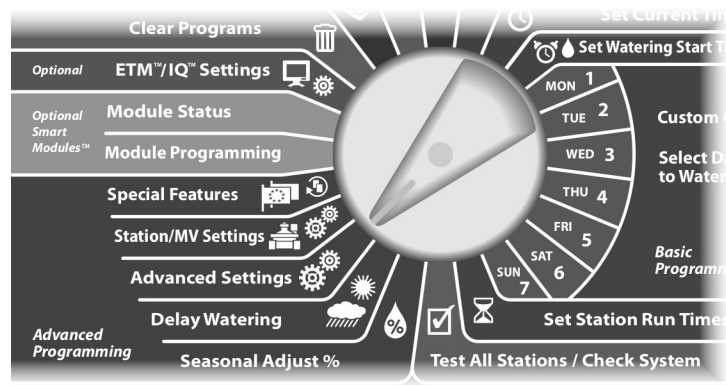

- The Advanced Settings screen appears with Watering Day Cycles selected. Press the Down Arrow button to select FloManager; then press Next.
- The FloManager screen appears with FloManager On/Off selected. Use the Down arrow to select FloManager Flow Rate; then press Next.

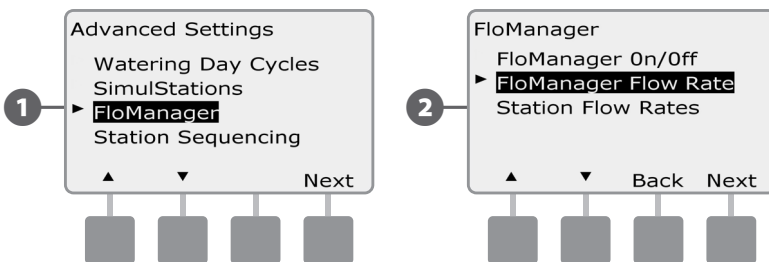

- The FloManager Max Flow Rate screen appears. Use the + and - buttons to enter the water source maximum flow rate.

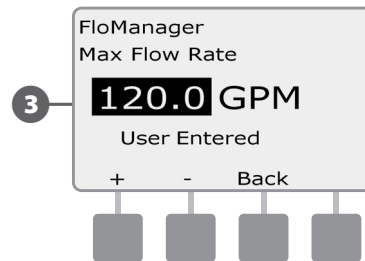

Set Station Flow Rates Manually

Flow rates for each station can be entered manually.

NOTE: If the optional FSM-LXME Flow Smart Module is installed then flow can be learned automatically. This is the easiest, most accurate method to enter flow readings. See Learn Flow section for more details.

Turn the controller dial to Advanced Settings.

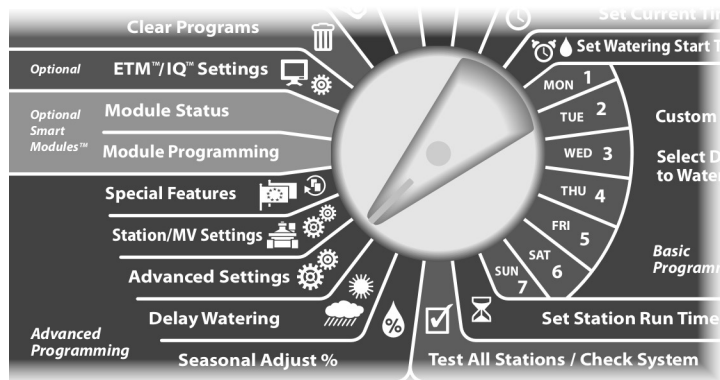

1 The Advanced Settings screen appears with Watering Day Cycles selected. Press the Down Arrow button to select FloManager; then press Next.

2 The FloManager screen appears with FloManager On/Off selected. Use the Down arrow to select Station Flow Rates; then press Next.

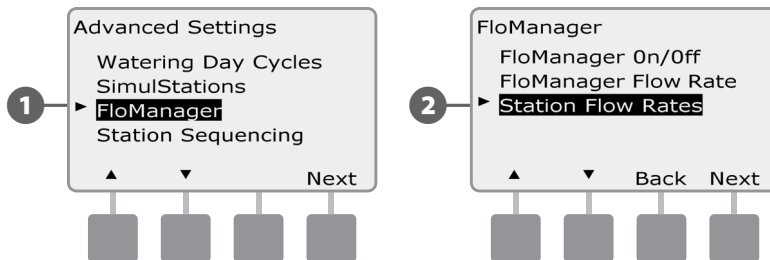

3 The Station Flow Rates screen appears. Press the + and - buttons on the left to select the desired station number.

4 Press the + and - buttons on the right to enter the Flow Rate for the selected station.

- Press and HOLD buttons to accelerate settings for Flow Rate.



Repeat this process to manually set up Flow Rates for additional stations as desired.

FloWatch™ Overview

The ESPLXME-ET controller can provide full-featured flow sensing by installing the optional FSM-LXME Flow Smart Module.

! **NOTE:** FloWatch flow sensing requires installation of the optional FSM-LXME Flow Smart Module and installation of a flow sensor and a master valve at the water source point of connection to the irrigation system.

FloWatch features include:

- Learn Flow Utility
- Seek and Eliminate Excessive Flow (SEEF)
- Seek and Eliminate Low Flow (SELF)
- Flow alarm and water use reporting

The ESPLXME-ET controller with installed FSM-LXME Flow Smart Module is compatible with the Rain Bird FS-Series Flow Sensors. Third party flow sensors are supported through entry of KFactor and Offset values. Normally-open and normally-closed master valves are supported.

Flow sensing benefits include:

- Water use tracking
- Automatic reaction to flow problems
- Minimizes property owner liability by limiting water loss and property damage caused by broken pipes or sprinklers

FloWatch™ Configuration

FloWatch configuration includes:

- Learn Flow Station Rates. Each station will be operated and the steady flow rate recorded. The recorded station flow rate is compared to the actual flow from the flow sensor each time the station operates.
- SEEF and SELF settings include deviation percentage, settling time and reaction to a problem.

Flow Sensor Hardware Installation

Installation of the Flow Smart Module (FSM-LXME), a flow sensor, and a master valve are required to use FloWatch.

Flow Smart Module

Replace the BM-LXME Base Module with the FSM-LXME Flow Smart Module.

! **NOTE:** If you purchased a flow-enabled version of the ESPLXME-ET Controller such as the ESPLXME-ETF, this step is unnecessary, since your controller shipped with the FSM-LXME Flow Smart Module.



FSM-LXME Flow Smart Module

! **NOTE:** The Flow Smart Module includes a jumper wire connecting the weather sensor (SEN) terminals. Do not remove the jumper wire unless you install a weather sensor.

- 1 Remove the BM-LXME Base Module from Slot 0 by pressing in on the two release buttons on either side of the module.

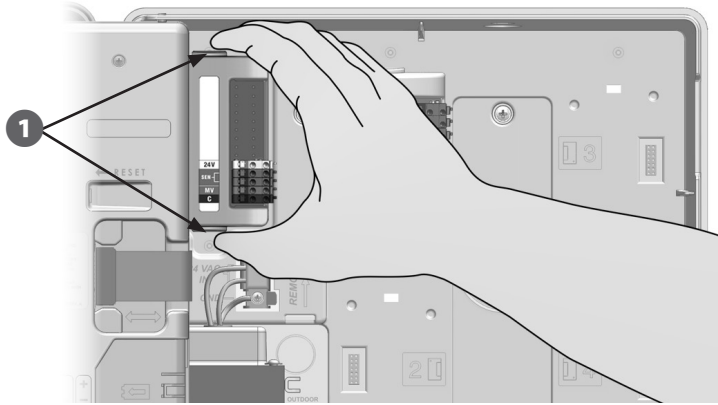

CAUTION: Be careful not to bend the pins in the sockets when installing the module.

- 2 Orient the connector on the bottom of the FSM-LXME Flow Smart Module with the connection socket in Slot 0 on the controller backplane.

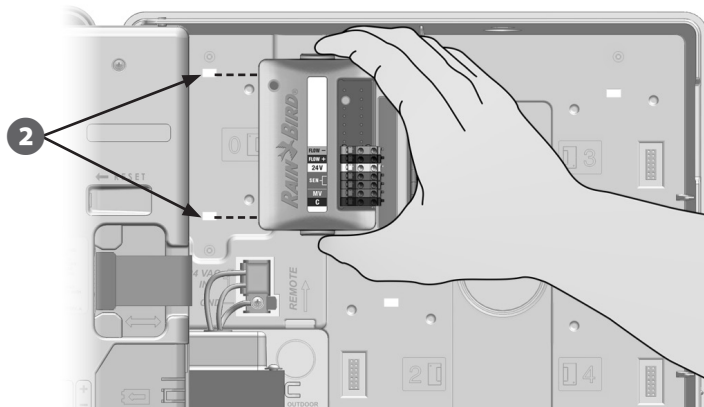

- 3 Carefully fasten the module onto the controller backplane, pressing firmly until it snaps into place. The red light on the module will flash on and off once if the module is installed correctly. If the light does not flash, verify the module is properly seated.

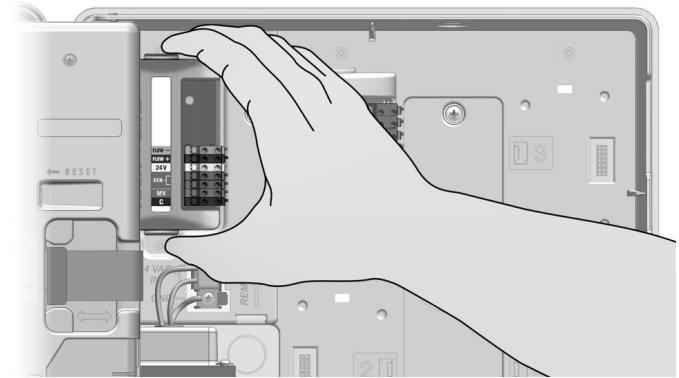

Connect Flow Sensor

- 1 Install the flow sensor in the field according to the manufacturer's instructions, and run the flow sensor wire to the ESPLXME-ET controller.
- 2 Route the flow sensor wire through the knockout on the bottom of the controller.
- 3 Connect the flow sensor wire to the Flow + and Flow - inputs. When finished, tug gently on the wires to make sure the connections are tight.

NOTE: For Rain Bird FS-Series flow sensors, connect the red sensor wire to the red (+) terminal and the black sensor wire to the grey (-) terminal.

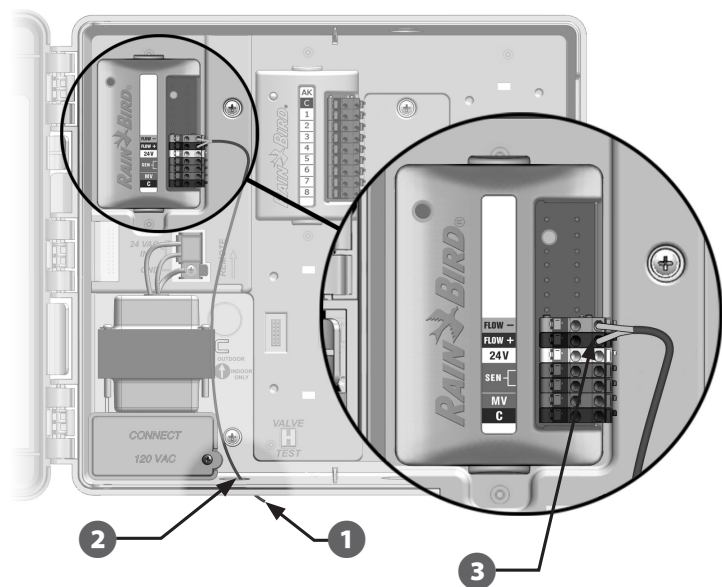

NOTE: The blue light on the FSM-LXME Flow Smart Module will flash as flow is measured by the flow sensor.

Module Programming

Setup Flow Sensor

- 1 Turn the controller dial to Module Programming.

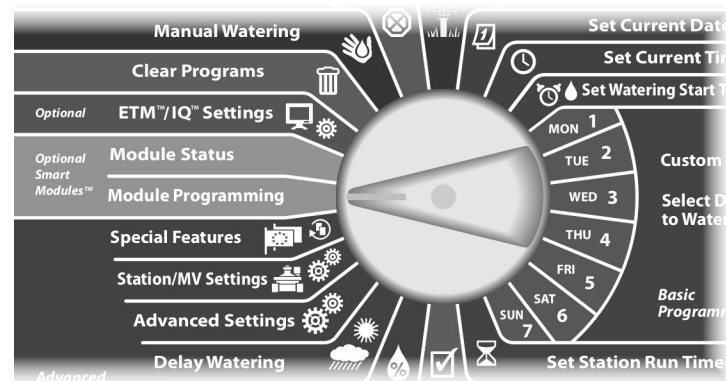

- 1 The Smart Module PGM screen appears with Flow Smart Module selected; press Next.
- 2 The Flow Smart Module PGM screen appears with Flow Sensor Setup selected; press Next.

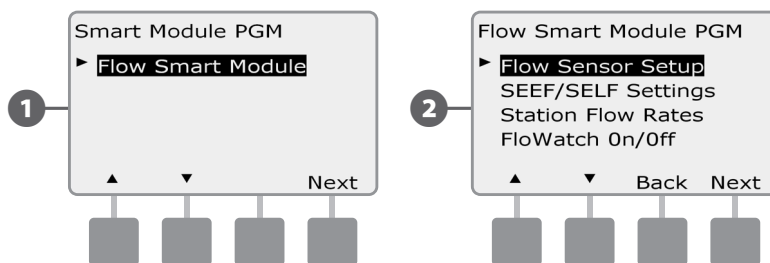

NOTE: If a FSM-LXME Flow Smart Module is not installed, the screens displayed on pages 58 through 72 will not be displayed.

3 The Flow Sensor Setup screen appears. Press the + and - buttons to select the type of sensor that is installed.

! **NOTE:** Some flow sensor types require extra parameter settings, such as inside pipe diameter or K-factor and Offset. Consult the manufacturers documentation or contact Rain Bird for assistance if required.

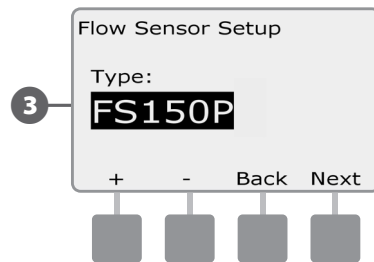

SEEF and SELF Settings and Actions

To most effectively use FloWatch, you will want to first set your SEEF and SELF thresholds and actions. SEEF stands for Seek and Eliminate Excessive Flow and deals with how you want your controller to respond when excessive flow is occurring, as might be the case with a mainline break. SELF stands for Seek and Eliminate Low Flow and deals with what the controller should do when low flow is present, as might be the case during a pump failure, municipal water supply issue or when a valve fails to open.

- Turn the controller dial to Module Programming.

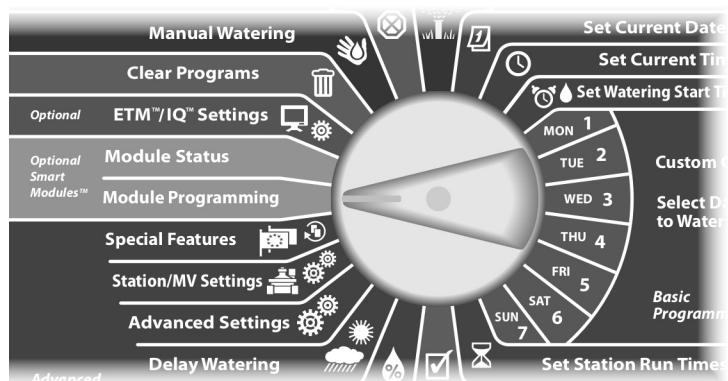

- 1 The Smart Module PGM screen appears with Flow Smart Module selected; press Next.
- 2 The Flow Smart Module PGM screen appears. Use the Down Arrow to select SEEF/SELF Settings; then press Next.

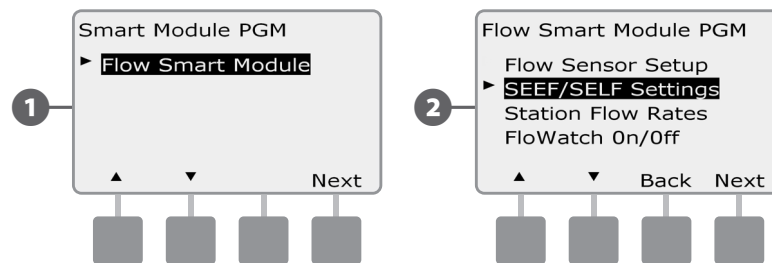

- 3 The SEEF Settings screen appears with High Flow Threshold selected, allowing you to set the top limit (between 105-200%) of station flow rate that must be achieved to be considered excessive. Press the + and – buttons to set the High Flow Threshold; then press Next.
 - Press and HOLD buttons to accelerate settings for percentages.
- ! **NOTE:** Consider using the default setting of 130% (or higher) for SEEF High flow Threshold. Using a lower percentage can result in false alarms due to normal hydraulic variability.
- 4 Settling Time is selected, allowing you to set the minimum time (from 3-10 minutes) that a flow rate must remain at (or above) the threshold before the controller will issue an alarm or take action. Press the + and – buttons to set the Settling Time; then press Next.



- 5 The SEEF Actions screen appears, allowing you to set the controller's behavior when a SEEF condition exists.
 - A. Diagnose and Eliminate allows the controller to determine if the high flow condition is due to a problem on the mainline (broken pipe, stuck valve, etc) or downstream of one of the valves that was running when the high flow condition was detected. The controller will eliminate the high flow condition by closing the Master Valve to eliminate a mainline problem or closing the problem valve to eliminate a problem with a station.
 - B. Shut Down and Alarm instructs the controller to shut down the Master Valve when a high flow condition is detected. The controller will not attempt to diagnose if the problem is on the mainline or downstream of a valve.
 - C. Alarm Only allows the controller to issue an alarm condition, but take no other action.

Press the + and – buttons to set the SEEF Action; then press Next.

- 6 The SELF Settings screen appears with Low Flow Threshold selected, allowing you to set the bottom limit (between 1-95%) that a station must achieve to be considered low flow. Press the + and – buttons to set the Low Flow Threshold; then press Next.
 - Press and HOLD buttons to accelerate settings for percentages.

NOTE: Consider using the default setting of 70% (or lower) for SEEF Low flow Threshold. Using a higher percentage can result in false alarms due to normal hydraulic variability.

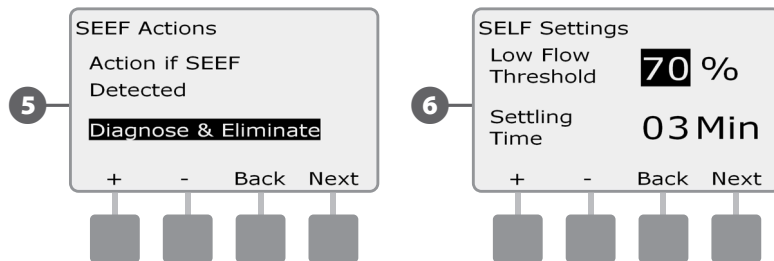

- 7 Settling Time is selected, allowing you to set the time limit (from 3-10 minutes) that a station flow rate must remain at (or below) the threshold before the controller will issue an alarm or take action. Press the + and – buttons to set the Settling Time; then press Next.
- 8 The SELF Actions screen appears, allowing you to set the controller's behavior when a SELF condition exists.
 - A. Diagnose and Eliminate allows the controller to determine if the low flow condition is due to a problem on the mainline (affects all valves) or downstream of one of the valves that was running when the low flow condition was detected. The controller will eliminate the low flow condition by closing the Master Valve to eliminate a mainline problem or closing the problem valve to eliminate a problem with a station.
 - B. Shut Down and Alarm instructs the controller to shut down the Master Valve when a low flow condition is detected. The controller will not attempt to diagnose if the problem is on the mainline or downstream of a valve.
 - C. Alarm Only allows the controller to issue an alarm condition, but take no other action.

Press the + and – buttons to set the SELF Action; then press Next.

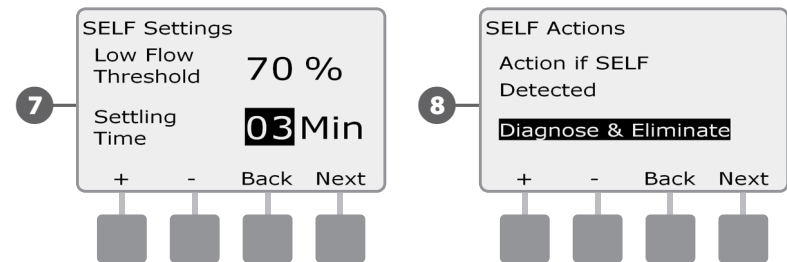

NOTE: If the selected action for **both** SEEF and SELF is Alarm Only, then the system is not disabled and the Delay to Re-Enable screen will not be shown.

- 9 The Delay to Re-Enable screen appears, allowing you to select how long (from 0 minutes to 24 hours) before your system is re-enabled to allow watering. If the flow condition still exists, SEEF or SELF will shut down the system again. Selecting the default of 0 minutes configures the controller to stay shut down until the flow alarm is manually cleared.

Press the + and – buttons to set hours before Re-Enable; then press Next.

- Press and HOLD buttons to accelerate settings for hours and minutes.

- 10 Press the + and – buttons to set minutes before Re-Enable; then press Next.

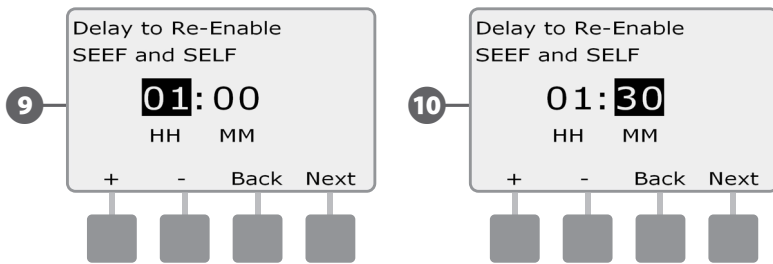

! **NOTE:** SEEF and SELF settings are not active until FloWatch is activated.

Station Flow Rates

Learn Flow Automatically (All Stations)

- Turn the controller dial to Module Programming.

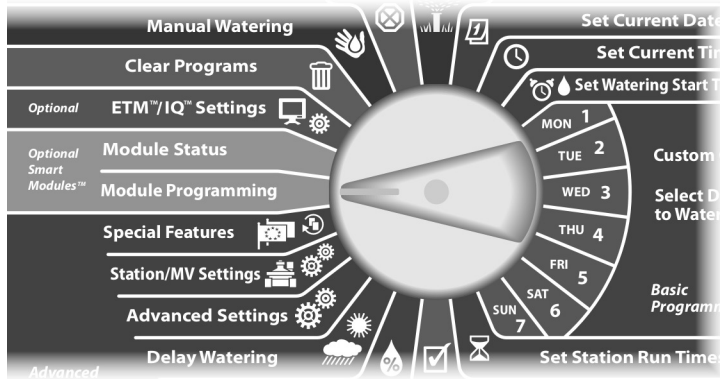

- The Smart Module PGM screen appears with Flow Smart Module selected; press Next.
- The Flow Smart Module PGM screen appears. Press the Down arrow to select Station Flow Rates; press Next.

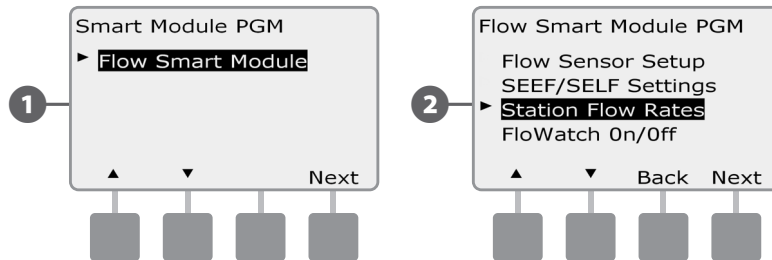

- The Set Flow Rates screen appears with Learn Flow selected; press Next.
- The Learn Flow screen appears with All Stations selected; press Next.

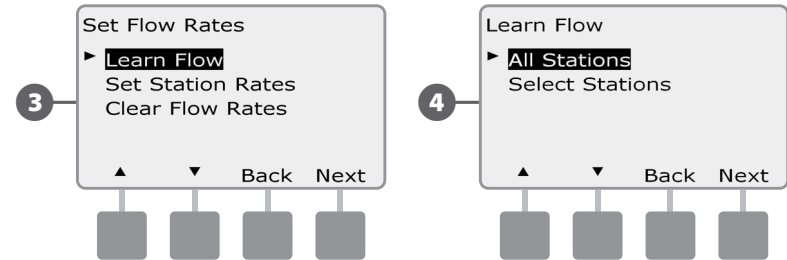

- NOTE:** Ensure you have runtimes set up for all stations included in a Learn Flow exercise prior to setting up a Learn Flow. Only stations with run times will be included in Learn Flow operation.

- A Learn Flow confirmation screen appears; press Next.
- A second Learn Flow confirmation screen appears; press Next.

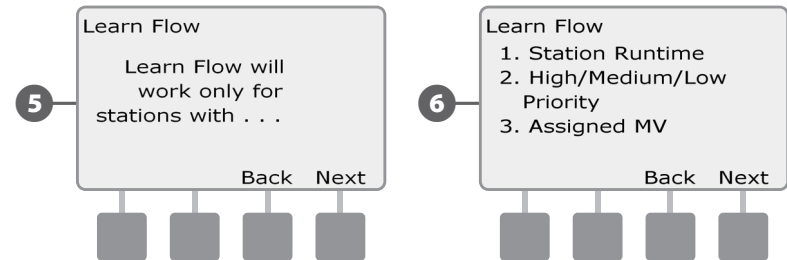

7 The Start Learn Flow screen appears. Press + and - to set the start time; then press Start.

- Press and HOLD buttons to accelerate settings for hours and minutes.

! **NOTE:** You can choose to run the exercise Now or choose a timed delay of up to 24 hours.

8 An overwrite warning screen appears; press Start.

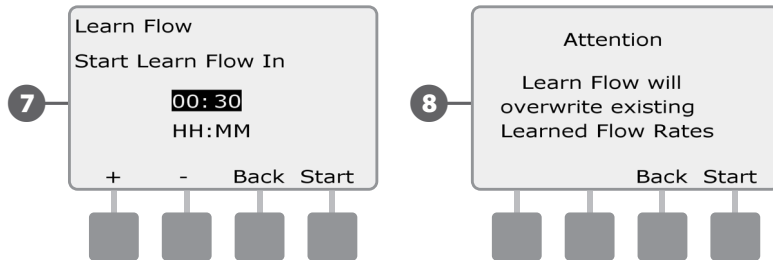

9 The Learn Flow Starting confirmation screen appears, confirming the delay time until the Learn Flow operation will start.

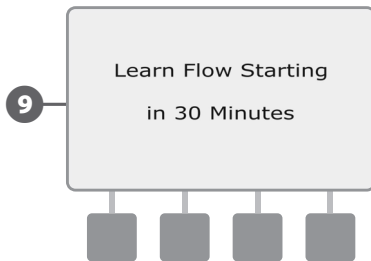

! **NOTE:** The Learn Flow Utility can take up to 5 minutes per station.

Learn Flow Automatically (Custom Stations)

- Turn the controller dial to Module Programming.

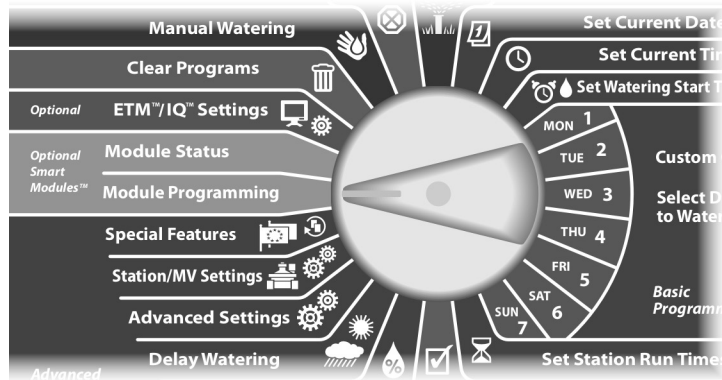

- The Smart Module PGM screen appears with Flow Smart Module selected; press Next.
- The Flow Smart Module PGM screen appears. Press the Down arrow to select Station Flow Rates; press Next.

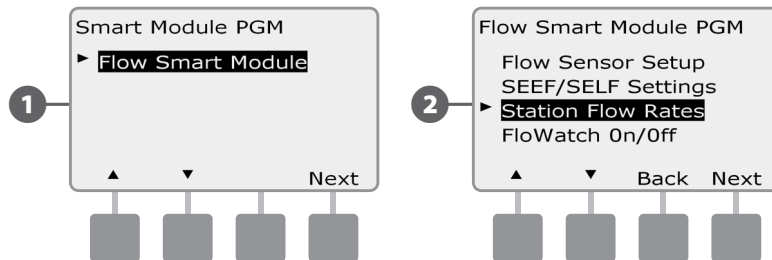

- The Set Flow Rates screen appears with Learn Flow selected; press Next.
- The Learn Flow screen appears. Press the Down Arrow to choose Select Stations; then press Next.

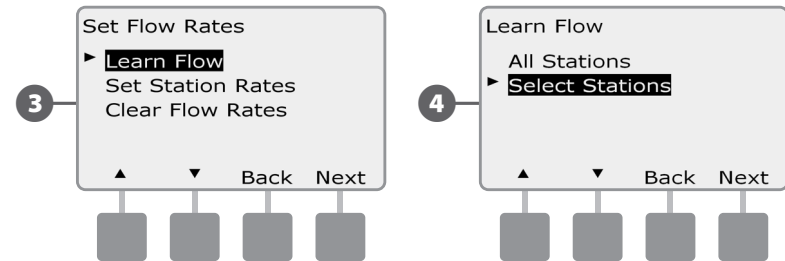

- NOTE:** Ensure you have runtimes set up for all stations included in a Learn Flow exercise prior to setting up a Learn Flow. If stations without run times are included in a Learn Flow exercise, the controller will issue an error message and cancel the Learn Flow exercise.

- A Learn Flow confirmation screen appears; press Next.
- A second Learn Flow confirmation screen appears; press Next.

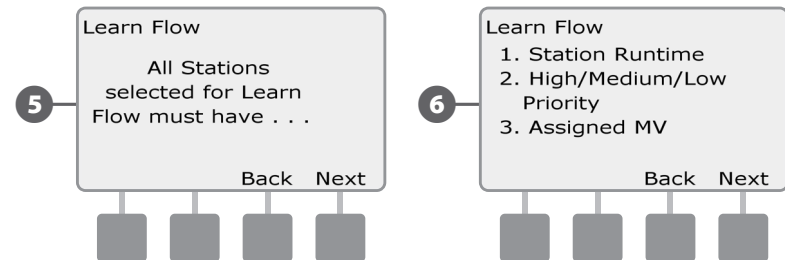

7 Press the Yes and No buttons to select the stations you would like to include. Press Next and Back buttons to select stations; then press Next.

8 Press the + and – buttons to set the time delay for when you want the Learn Flow exercise to start; then press Start.

- Press and HOLD buttons to accelerate settings for hours and minutes.

! **NOTE:** You can choose a delay between 0 hours, 0 minutes up to 24 hours.

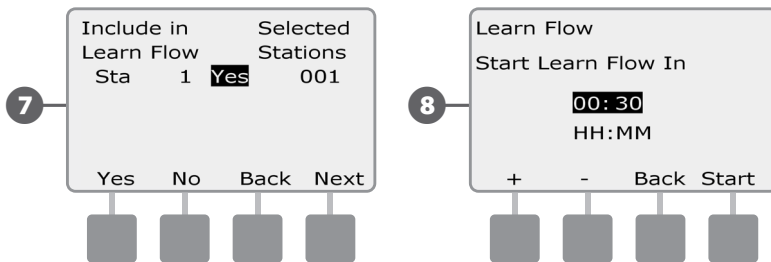

9 A confirmation screen appears; press Start again to set the Learn Flow exercise.

10 The Learn Flow Starting confirmation screen appears, confirming the delay time until the Learn Flow operation will start.

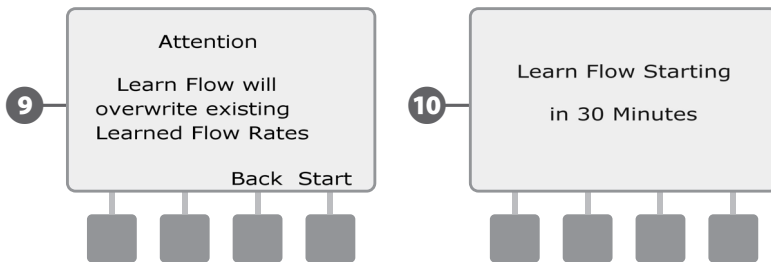

! **NOTE:** Station flow rates can still be entered manually if desired. See FloManager section for details.

! **NOTE:** The Learn Flow Utility can take up to 5 minutes per station.

Set Station Flow Rates Manually

Allowing the controller to Learn Flow automatically is the easiest, most accurate method to enter flow readings, but flow sensing hardware and the Flow Smart Module are required for this. However, even if you do not have flow sensing hardware installed you can manually enter flow rates for one or more stations or flow zones before or after an automatic Learn Flow exercise.

Turn the controller dial to Module Programming.

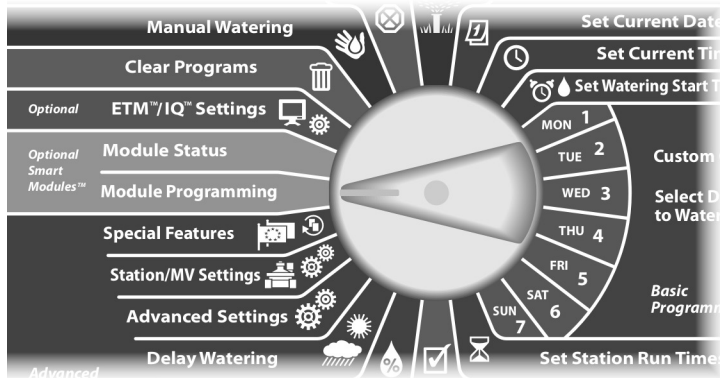

- 1 The Smart Module PGM screen appears with Flow Smart Module selected; press Next.
- 2 The Flow Smart Module PGM screen appears with Set Flow Rates selected; press Next.

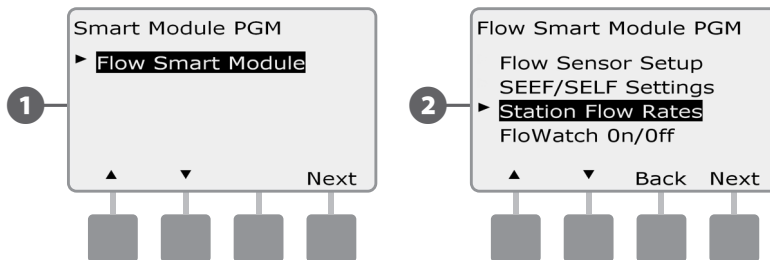

- 3 The Set Flow Rates screen appears. Press the Down Arrow button to select Set Station Rates; then press Next.
- 4 Press + and - (buttons 1 and 2) to select the desired station number; then press - (button 4).

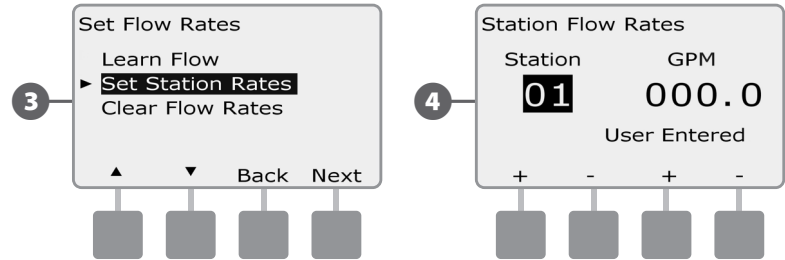

- 5 Press + and - (buttons 3 and 4) to enter the desired Flow Rate for that station. Press - (buttons 2 and 4) to navigate between the station and flow rate fields.
 - Press and HOLD buttons to accelerate settings for GPM.

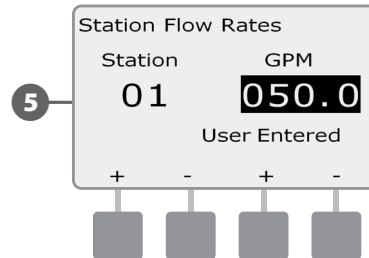

- Repeat this process to manually set up Flow Rates for additional stations as desired.

Clear Flow Rates

Occasionally it may be desired to clear the previously learned or user entered flow rates and start all over again.

- Turn the controller dial to Module Programming.

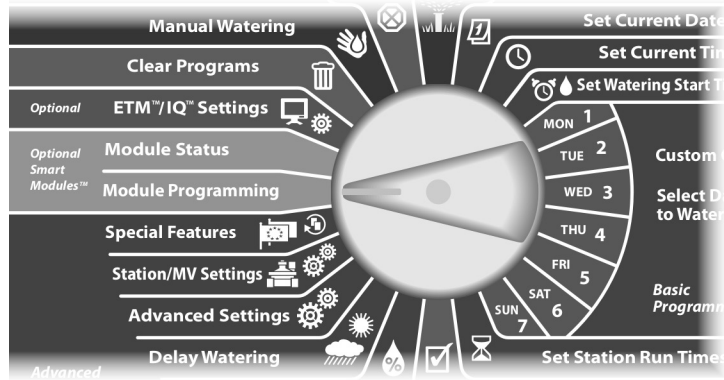

- 1 The Smart Module PGM screen appears with Flow Smart Module selected; press Next.
- 2 The Flow Smart Module PGM screen appears. Press the Down Arrow button to select Station Flow Rates; press Next.

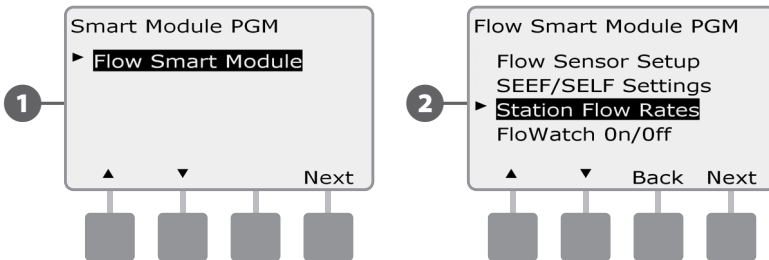

- 3 The Set Flow Rates screen appears. Press the Down Arrow button to select Clear Flow Rates; then press Next.
- 4 The confirmation screen appears; press Next to clear flow rates.

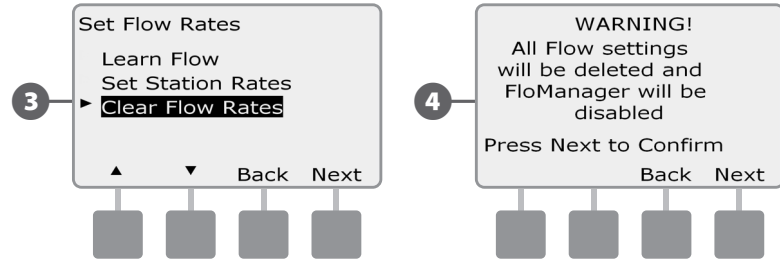

Enable (or Disable) FloWatch™

- Turn the controller dial to Module Programming.

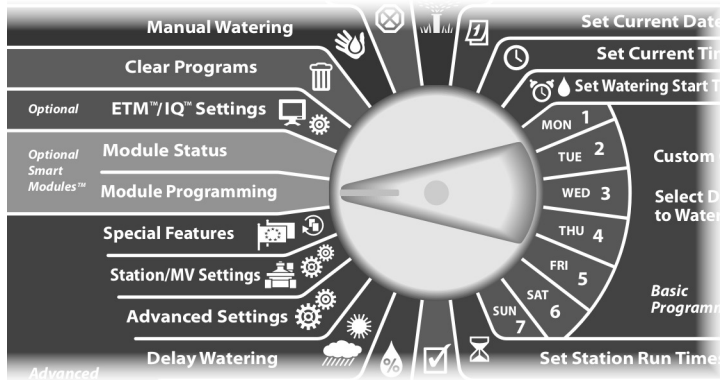

- The Smart Module PGM screen appears with Flow Smart Module selected; press Next.
- The Flow Smart Module PGM screen appears. Use the Down Arrow to select FloWatch On/Off; then press Next.

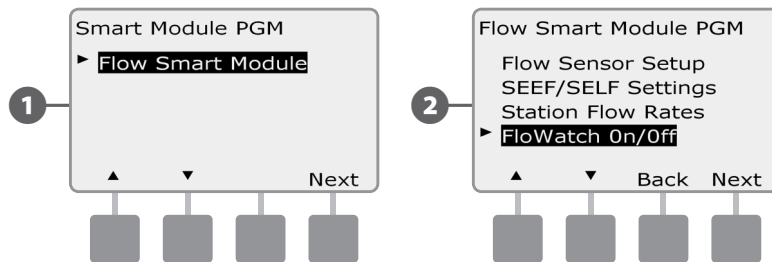

- The FloWatch screen appears. Press the On button to enable FloWatch, or else press Off to disable

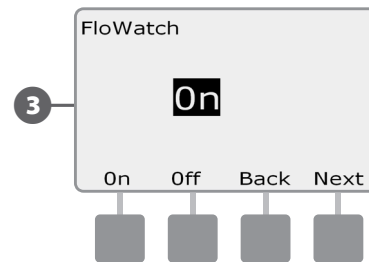

- NOTE:** Once FloWatch is enabled we recommend that you Learn Flow for all stations if you have not already done so. This will allow FloWatch to react appropriately to the SEEF and SELF settings.

Module Status

View and Clear Flow Alarms

Occasionally a flow condition in excess of your SEEF settings or below your SELF settings will be detected. If your controller is set up to issue alarms for these conditions, the alarm light will illuminate and detailed descriptions of the Flow Alarm conditions will be created.

View Station Flow Alarms

Turn the controller dial to Module Status.

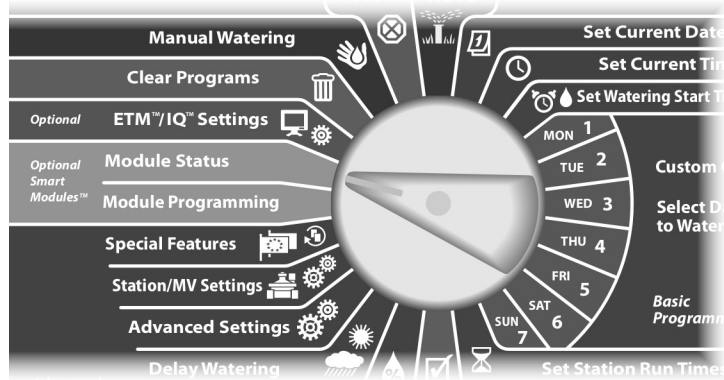

- 1 The Smart Module Status screen appears with Flow Smart Module selected; press Next.
- 2 The Flow Module Status screen appears with View Flow Alarms selected; press Next.

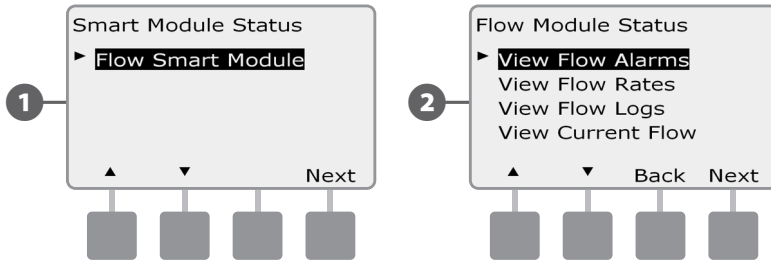

- 3 The Review/Clear Alarms screen appears with Station Flow Alarms selected; press Next.
- 4 The Station Flow Alarms screen appears. Press the Up and Down arrows buttons to view the Flow Alarms. Stations with Flow Alarm conditions will display "Yes" - only alarmed stations will be shown.

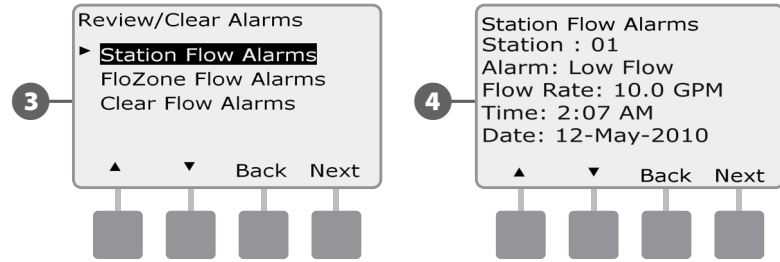

View Mainline Flow Alarms

- 1 Turn the controller dial to Module Status.

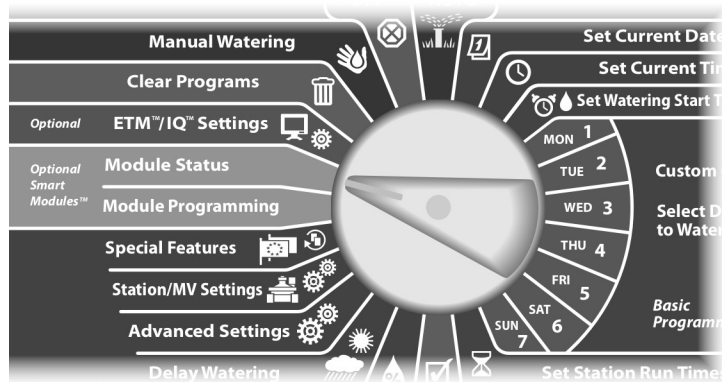

- 2 The Smart Module Status screen appears with Flow Smart Module selected; press Next.
- 3 The Flow Module Status screen appears with View Flow Alarms selected; press Next.

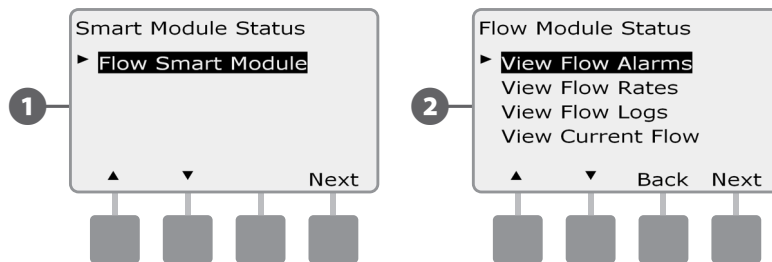

- 4 The Review/Clear Alarms screen appears. Press the Down Arrow button to select Mainline Flow Alarms; then press Next.
- 5 The Mainline Flow Alarms screen appears. If no Mainline Flow Alarms have been posted you will see the screen below.

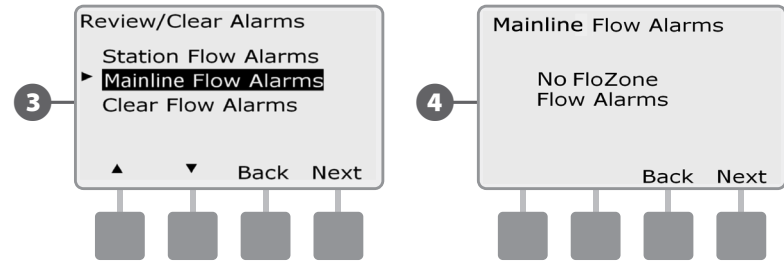

Note each station which has an alarm, then See Clear Flow Alarms in this section for more details on how to clear flow alarms.

NOTE: Mainline alarms indicate alarms for mainline flow conditions, not stations.

Clear Flow Alarms

- Turn the controller dial to Module Status.

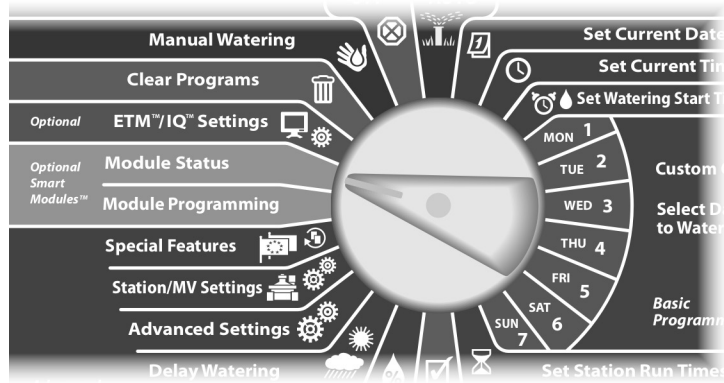

- The Smart Module Status screen appears with Flow Smart Module selected; press Next.
- The Flow Module Status screen appears with View Flow Alarms selected; press Next.

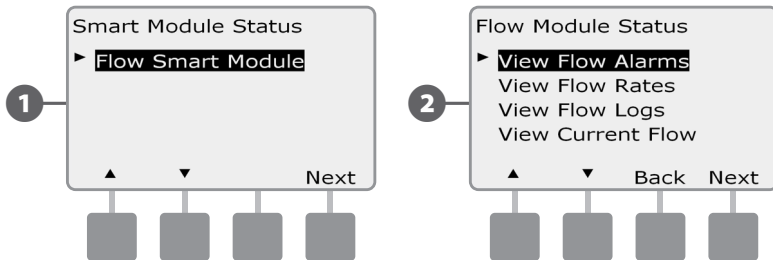

- The Review/Clear Alarms screen appears. Press the Down Arrow button to select Clear Flow Alarms; then press Next.
- The Clear Flow Alarms screen appears with all current Flow Alarms displayed and you will have the opportunity to clear each. It may be helpful to record which stations have Flow Alarm conditions prior to clearing them.

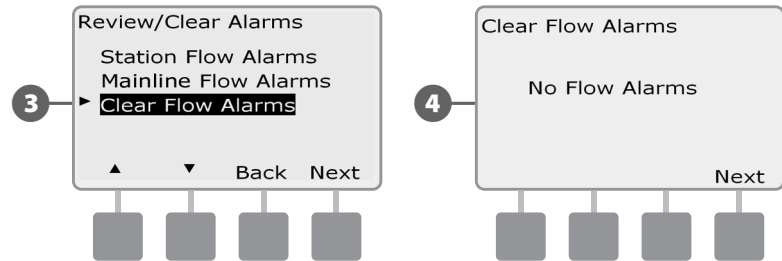

- NOTE:** Mainline alarms indicate alarms for mainline flow conditions, not stations.

View Flow Rates

Occasionally you may want to view flow rates for a station or the water source.

- Turn the controller dial to Module Status.

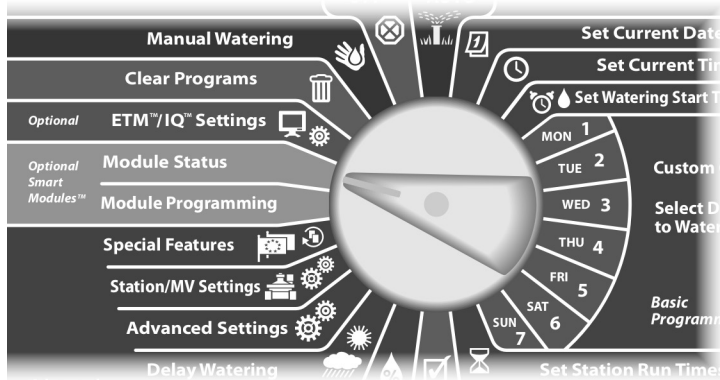

- The Smart Module Status screen appears with Flow Smart Module selected; press Next.
- The Flow Module Status screen appears. Press the Down Arrow button to select View Flow Rates; then press Next.

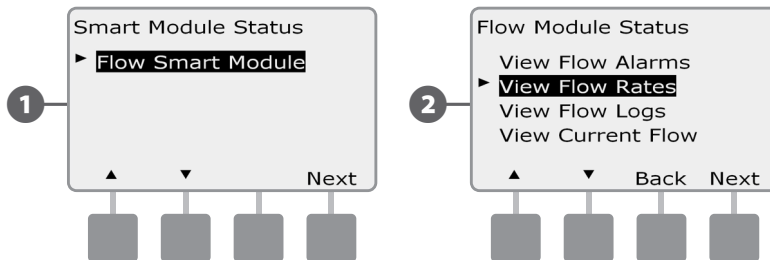

- The Flow Rates screen appears with View Station Rates selected; press Next.
- The Station Flow Rates screen appears. Press the + and – buttons to select the desired station number. The normal flow rate for each station will display to the right, and the source of the flow rate (Learned or User Entered) displays below it.

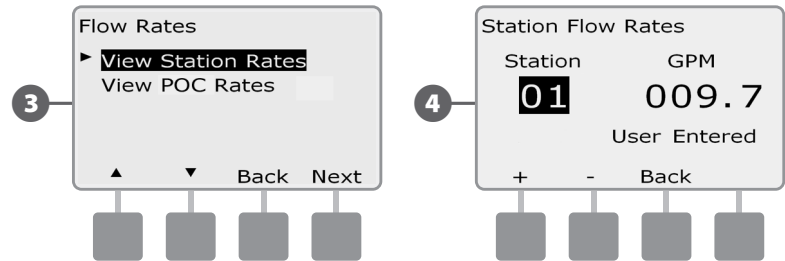

NOTE: POC rate is the maximum flow rate for the water source.

View and Clear Flow Logs

With FloWatch enabled, the controller will automatically track the volume of water flowing through the system. This can be useful for checking your actual water consumption against your water bill.

- Turn the controller dial to Module Status.

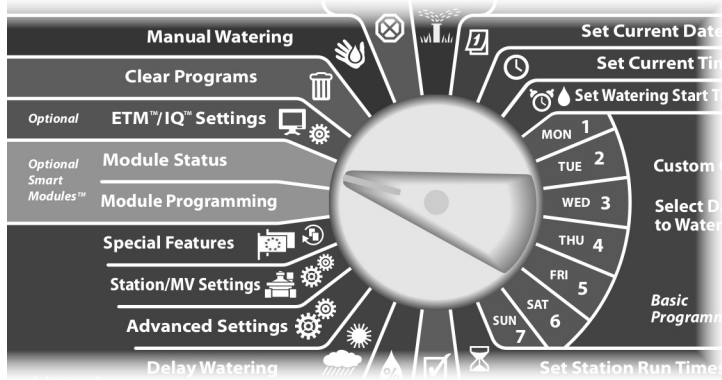

- The Smart Module Status screen appears with Flow Smart Module selected; press Next.
- The Flow Module Status screen appears. Press the Down Arrow button to select View Flow Logs; then press Next.

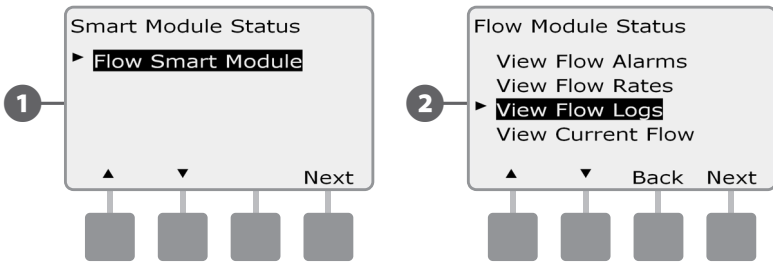

- The Flow Logs screen appears, showing month-to-date and last month water consumption (in gallons).
- Press the Days button to change the view to the last 30 days and previous 30 days.

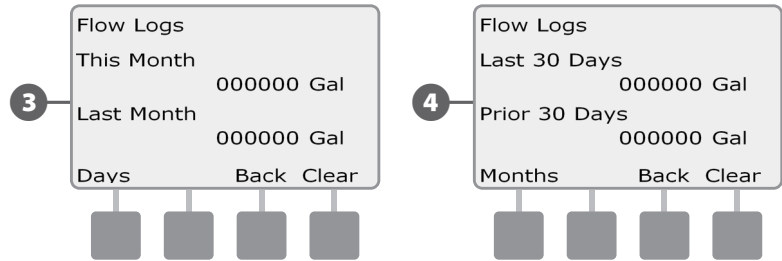

- If you would like to clear the log information, press the Clear button.

NOTE: Pressing Clear from either the monthly or daily screen will clear BOTH monthly and daily flow log data.

- The confirmation screen appears; press Yes to clear the logs.

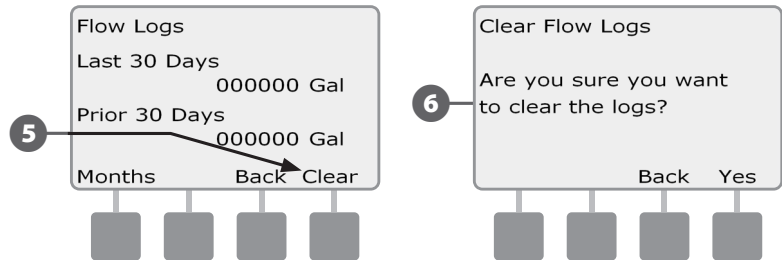

View Current Flow

Occasionally it may be useful to check the current flow rate and how it compares to previously learned or user input flow rates.

- Turn the controller dial to Module Status.

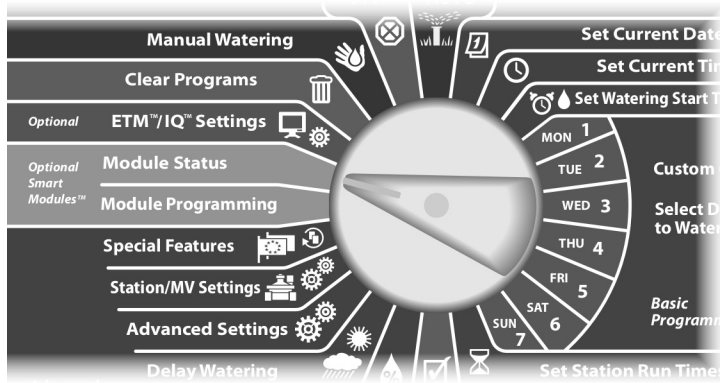

- The Smart Module Status screen appears with Flow Smart Module selected; press Next.
- The Flow Module Status screen appears. Press the Down Arrow button to select View Current Flow; then press Next.

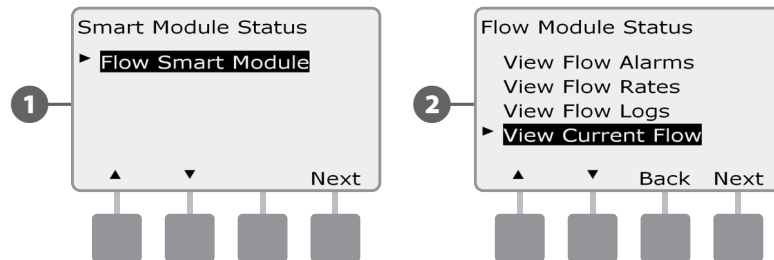

- Current and expected flow will display.

NOTE: Expected flow is from previously user-entered or learned flow. The deviation or percentage comparison of current flow to expected flow will display so you can see how close the system is to a SEEF or SELF condition (see Setting Up SEEF and SELF for more details).

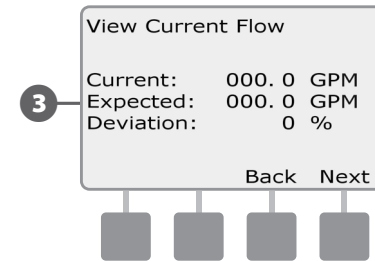

this page intentionally left blank

Section F - Options & Special Features

Set Language

You can set the ESPLXME-ET controller to one of six supported languages; English, Spanish, French, Portuguese, Italian or German. Changes to the default language affect all screens and menus.

- 1 Turn the controller dial to Special Features.

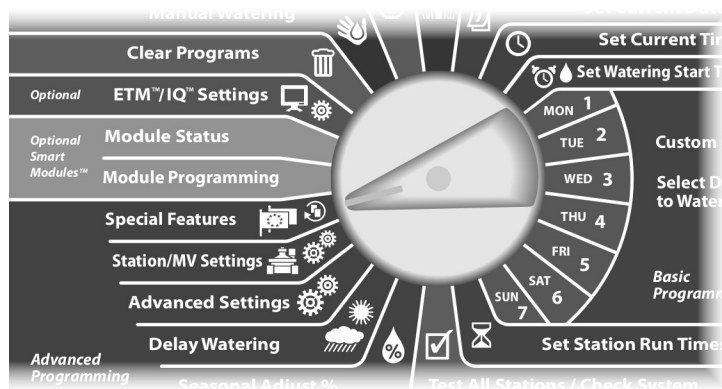

- 1 The Special Features screen appears with Set Language selected; press Next.
- NOTE:** If the controller is set to a language you do not speak, Set Language is the top item on the Special Features main menu.
- 2 The Set Language screen appears. Press the + and - buttons to select the desired language.

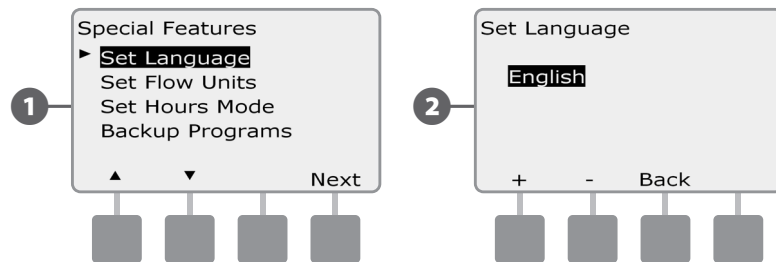

Set Hours Mode

You can set the ESPLXME-ET controller to display time in one of three hours modes: Auto (default for your region), AM/PM or 24 Hour.

- 1 Turn the controller dial to Special Features.

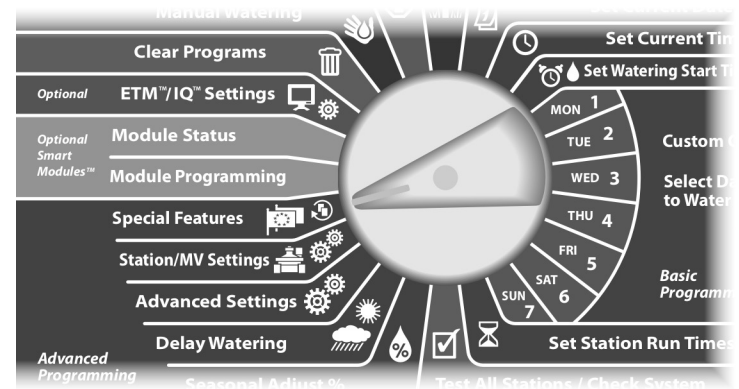

- 1 The Special Features screen appears with Set Language selected. Press the Down Arrow button to select Set Hours Mode; then press Next.
- 2 The Set Hours Mode screen appears. Press the + and - buttons to select the desired hours mode.

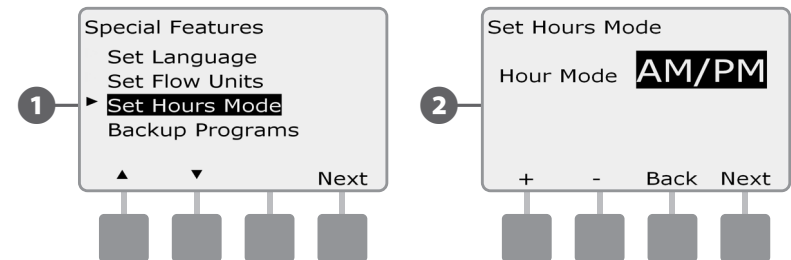

Backup and Recall Programs

The ESPLXME-ET controller comes standard with a simple to use backup programs feature.

Backup Programs allows you to save your programs as Contractor Default and then recall them at a later time. It also includes a Delayed Recall feature that lets you save a normal irrigation schedule as the Backup and then restore it later automatically. This may be useful for new seed or sod where frequent irrigation can be programmed to occur until a set date when Delayed Recall automatically returns the controller programming to the normal irrigation schedule.

 **CAUTION:** The Backup Programs feature saves and restores ALL irrigation programming in ALL programs (A, B, C & D), and also all settings for the ET Manager Cartridge.

Store Default Programs

 Turn the controller dial to Special Features.

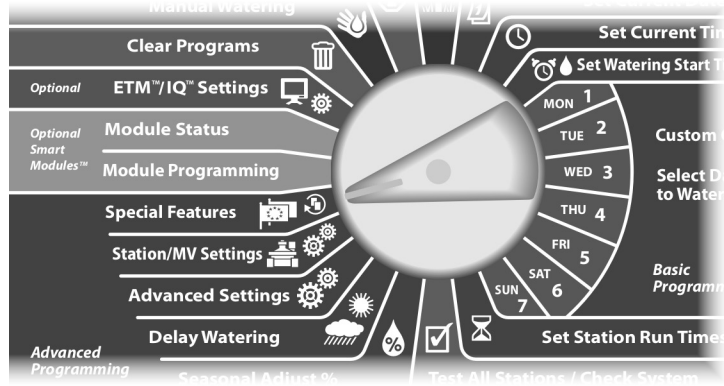

- 1 The Special Features screen appears. Press the Down Arrow button to select Backup Programs; then press Next.
- 2 The Backup Programs screen appears with Store Programs selected; press Next.

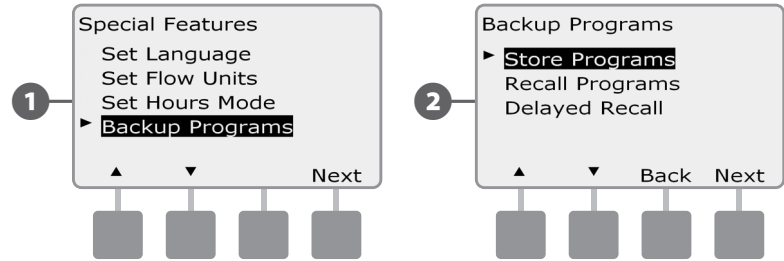

- 3 A confirmation screen appears. To Store Programs, press and hold the Yes button for four seconds. If you're not sure, press No.
- 4 A confirmation screen appears.

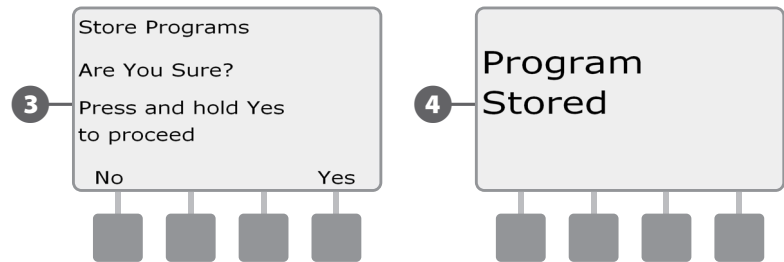

Recall Default Programs

- 1 Turn the controller dial to Special Features.

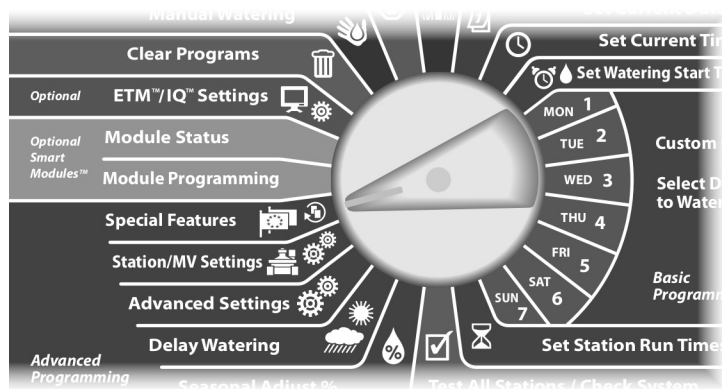

- 2 The Special Features screen appears. Press the Down Arrow button to select Backup Programs; then press Next.
- 3 The Backup Programs screen appears. Press the Down Arrow button to select Recall Programs; then press Next.

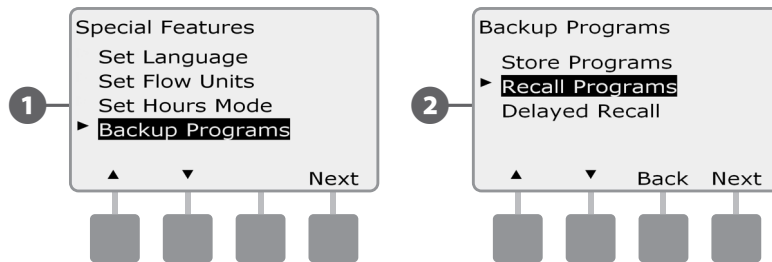

- 3 A confirmation screen appears. To Recall Programs, press and hold down the Yes button for four seconds. If you're not sure, press No.

- 4 A confirmation screen appears.

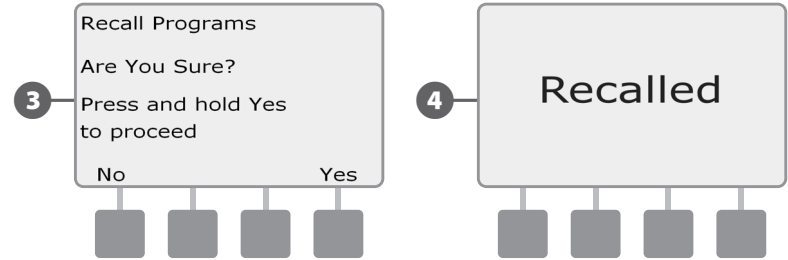

- CAUTION:** Once current programs have been replaced using Recall Programs they can not be restored.

Delayed Recall

Use the Delayed Recall feature to automatically replace the currently loaded programs with a previously stored program at a future date.

CAUTION: Once current programs have been replaced with the Delayed Recall feature, they can not be restored.

Turn the controller dial to Special Features.

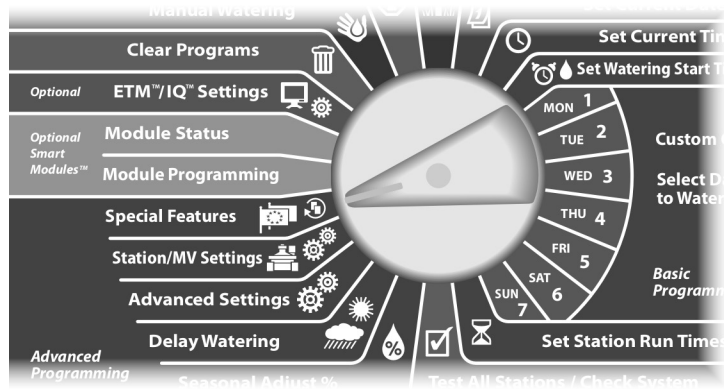

1 The Special Features screen appears. Press the Down Arrow button to select Backup Programs; then press Next.

2 The Backup Programs screen appears. Press the Down Arrow button to select Delayed Recall; then press Next.

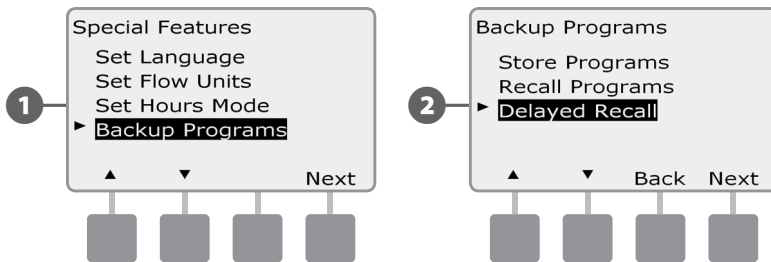

3 The Recall Delay screen appears. Press the + and - buttons to enter the number of days (from 0 to 90 days) before Contractor Defaults are restored. For example, set it to 7 days if you want your original programs to be restored in one week. If you want to clear a previously Delayed Recall, set the number of days to 0.

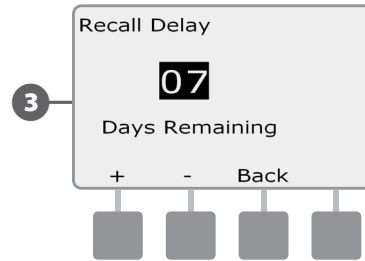

Section G - Auxiliary Operation

Clear Programs

The ESP-LXME controller allows you to clear an individual Program, all of your Programs, or to Restore the controller to its factory default condition.

CAUTION: It's recommended to back up your Programs before clearing them. The ESP-LXME controller's built in Store Programs feature can backup one set of programs. See Section F, Backup and Recall Programs for more details.

NOTE: Irrigation start days, Start Times and station Run Times will no longer be present for the cleared Programs. If no Programming exists then an Alarm will be displayed. See Section A, Alarm Conditions for more details.

Clear Individual Program

Turn the controller dial to Clear Programs.

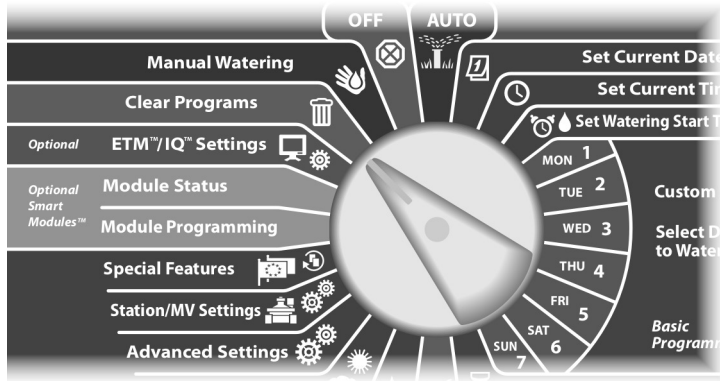

- 1 The Clear Programs screen appears with Individual Program selected; press Next.
 - 2 A confirmation screen appears. To clear the selected Program, press and hold down the Yes button for four seconds. If you're not sure, press No.
- NOTE:** If the desired program is not selected, use the Program Select switch to change it. See Section B, Program Select Switch for more details.

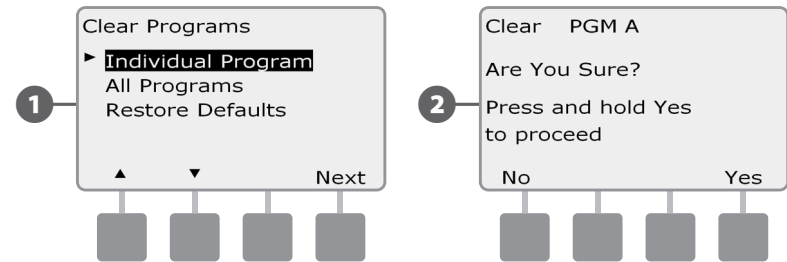

- 3 A confirmation screen appears.

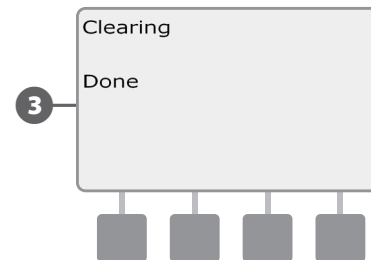

- Change the Program Select switch and repeat this process to clear other Programs.

Clear All Programs

- Turn the controller dial to Clear Programs.

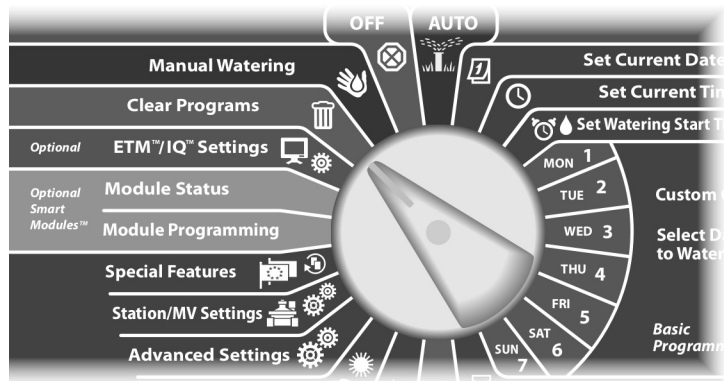

- The Clear Programs screen appears. Press the Down Arrow button to select All Programs; then press Next.
- A confirmation screen appears. To Clear All Programs, press and hold down the Yes button for four seconds. If you're not sure, press No.

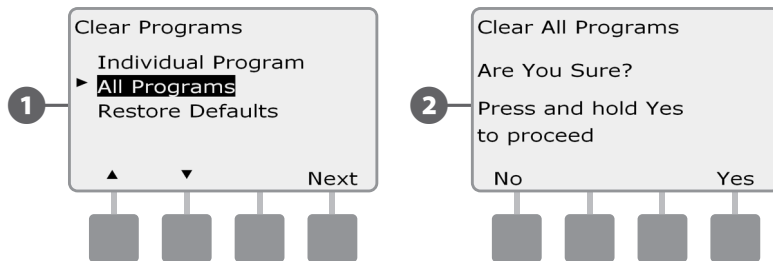

- A confirmation screen appears.

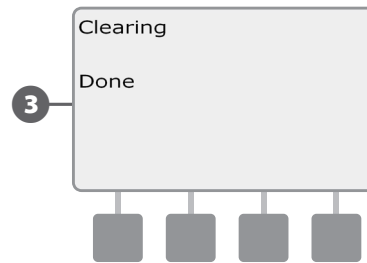

Restore Defaults

Restore the ESP-LXME controller's factory default settings.

- Turn the controller dial to Clear Programs.

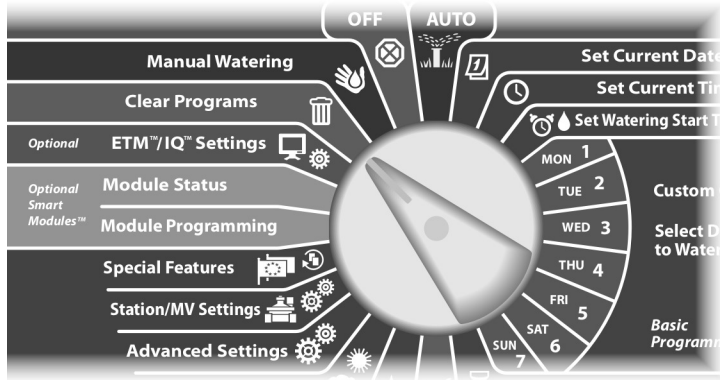

- The Clear Programs screen appears. Press the Down Arrow button to select Restore Defaults; then press Next.
- A confirmation screen appears. To Restore Factory Defaults, press and hold down the Yes button for four seconds. If you're not sure, press No.

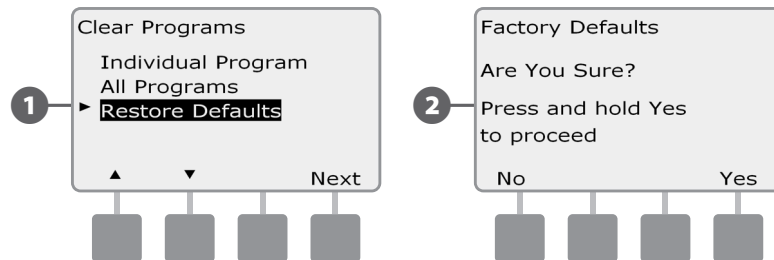

- A confirmation screen appears.

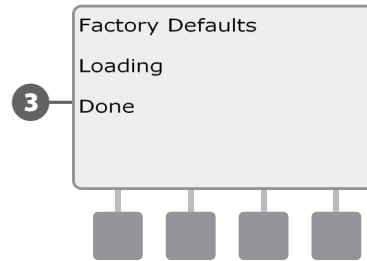

- CAUTION:** Be very careful about using the Restore Defaults option as all previous settings will be permanently cleared from system memory. Consider using the Clear All Programs option instead. Restore Defaults will NOT affect the ET Manager Cartridge settings.

Manual Watering

The ESP-LXME controller allows you to manually start a station, a program, or to open a Normally Closed Master Valve (NCMV) to provide water to your irrigation system for manual watering.

Manual Watering will automatically set the Seasonal Adjust percentage to 100%. Prior to the next scheduled start time, the ET Manager will change the Seasonal Adjust percentage back to the proper adjusted value to reflect the current Moisture Level.

NOTE: Manual Watering is NOT tracked by the ET Manager. The ET Manager will calculate watering needs as if the manual watering had not occurred.

NOTE: Manual operation will ignore local weather sensor and start irrigation even if the local weather sensor is preventing automatic irrigation.

Start Station Manually

NOTE: Manual Watering > Start Station will pause currently running programs.

Turn the controller dial to Manual Watering.

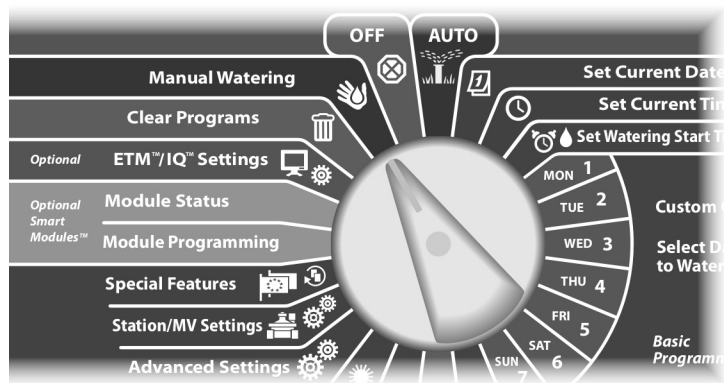

1 The Manual Watering screen appears with Start Station selected; press Next.

2 The Manual Watering screen appears. Press the + and – buttons to enter the station you want to run manually; then press Next.

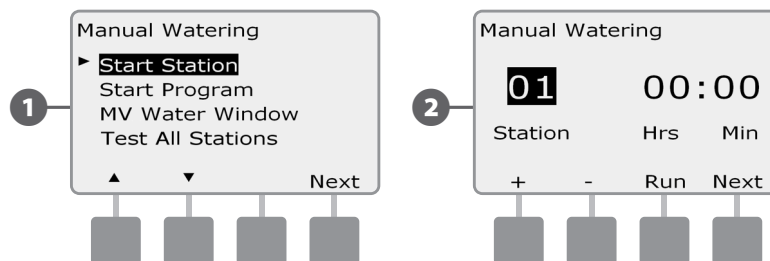

3 The Station Run Time will default to the Program Run Time. Press the + and – buttons to adjust the station Run Time (from 0 hours, 1 minute to 12:00 hours). Press the Run button to start irrigation for that station.

- Press and HOLD buttons to accelerate settings for hours and minutes.

4 A confirmation screen appears.

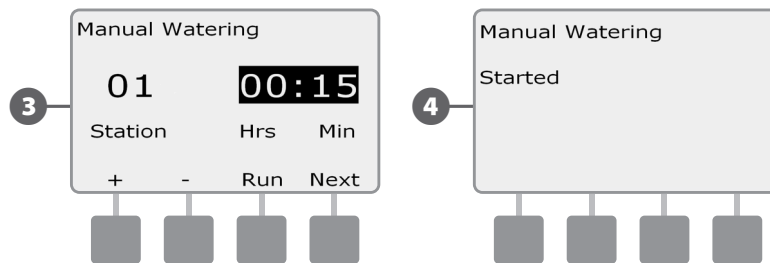

Repeat this process to manually water other stations.

NOTE: Stations will run sequentially in the order in which they were selected.

NOTE: To view the Station while running, turn the controller dial to AUTO position. You can use the Adv button to advance to the next station and the + and – buttons to increase or decrease the Run Time of the current station.

Start Program Manually

- 1 Turn the controller dial to Manual Watering.

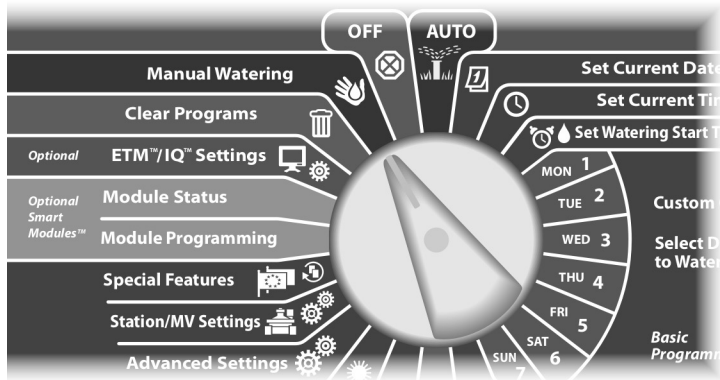

- 1 The Manual Watering screen appears. Press the Down Arrow button to select Start Program; then press Next.
- 2 The Manual Watering Start Program screen appears. Press Run to start the Program or else press Back to cancel.

! **NOTE:** If the desired program is not selected, use the Program Select switch to change it. See Section B, Program Select Switch for more details.

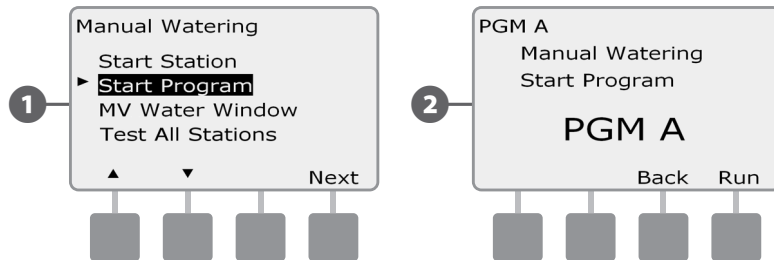

- 3 A confirmation screen appears.

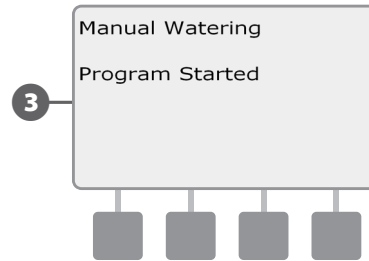

- 3 Repeat this process to manually start other Programs. Programs will run sequentially in the order in which they were selected.

! **NOTE:** To view the Program while running, turn the controller dial to AUTO position. You can use the Adv button to advance to the next station and the + and – buttons to increase or decrease the Run Time of the current station.

MV Water Window

Sometimes you may want to use quick coupling valves or other manual watering methods during times when you are not irrigating. To ensure that these devices have water, you can set up an MV Water Window. The MV Water Window works the same way as other Water Windows, but instead of allowing irrigation it simply opens the Normally Closed master valve (NCMV) and allows a user-defined flow rate to coordinate with flow sensing if installed.

Set Up MV Water Window

- Turn the controller dial to Manual Watering.

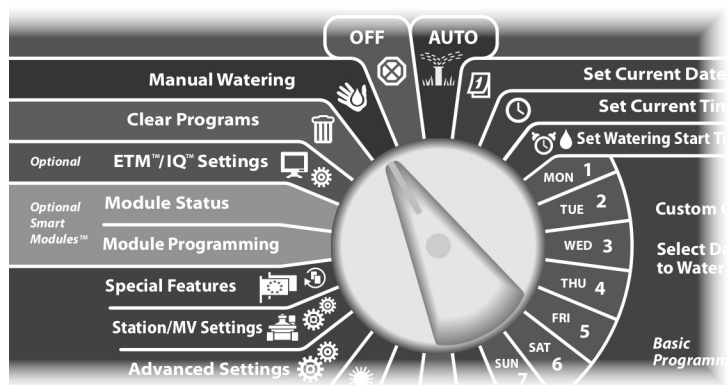

- The Manual Watering screen appears. Press the Down Arrow button to select MV Water Window ; then press Next.
- The MV Water Window screen appears with MV Water Window selected; press Next.

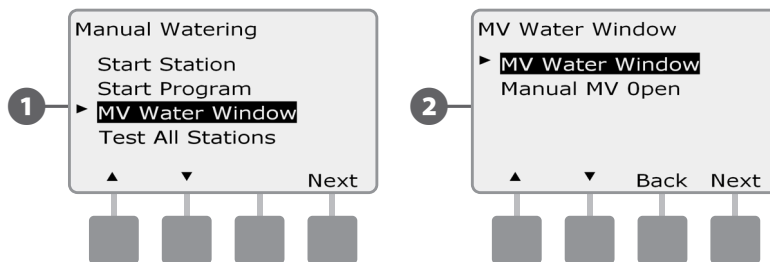

- Press the + and – buttons to set the time when the MV Water Window opens; then press Next.
 - Press and HOLD buttons to accelerate settings for hours and minutes.
- Press the + and – buttons to set the time when the MV Water Window closes. As you adjust the end time, the duration of your MV Water Window calculates automatically; then press Next.

NOTE: To clear a previously set MV Water Window, press the + and – buttons to set both the Open and Close times to OFF (between 11:59 PM and 12:00 AM).

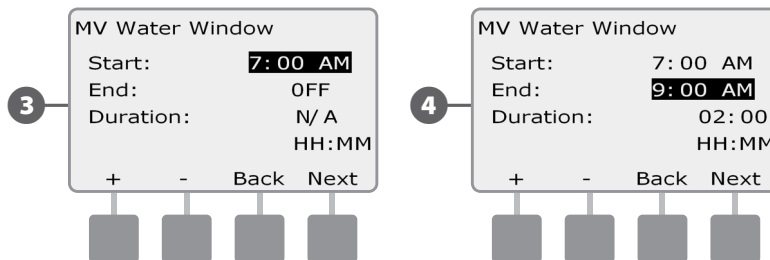

- 5 The MV Water Window Days Manual Watering Allowed On screen appears. Press the Yes button to allow MV Manual Watering to occur on a given day or press No to exclude that day.
- 6 Press the Next and Back buttons to navigate through the days of the week and repeat the selection process as desired; then press Next to navigate past Sunday.

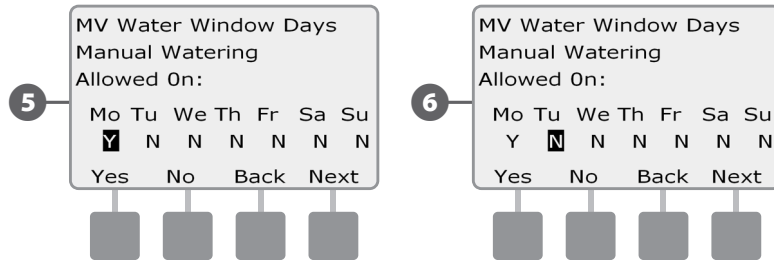

- 7 If the optional FSM-LXME Flow Smart Module is installed and FloWatch is enabled, the controller will request a maximum additional flow rate allowed for the MV Water Window. Press the + and - buttons to enter a sufficiently large value so that flow from hoses and other manual watering devices will not trigger a FloWatch SEEF High Flow alarm.

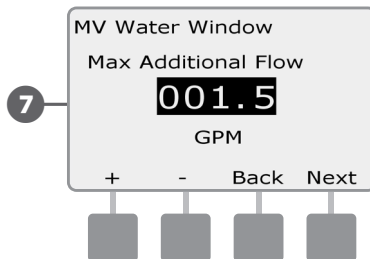

Manually Opening a MV

Occasionally it may be necessary to provide water to the system for unscheduled tasks. The Open MV feature allows you to leverage settings, such as allowable incremental flow, from your MV Water Window to open normally closed MVs for a user-selected duration.

- Turn the controller dial to Manual Watering.

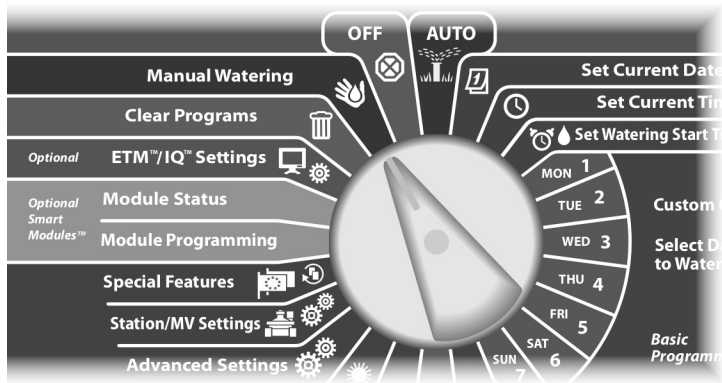

- ➊ The Manual Watering screen appears. Press the Down Arrow button to select MV Water Window ; then press Next.
- ➋ The MV Water Window screen appears. Press the Down Arrow button to select Manual MV Open ; then press Next.

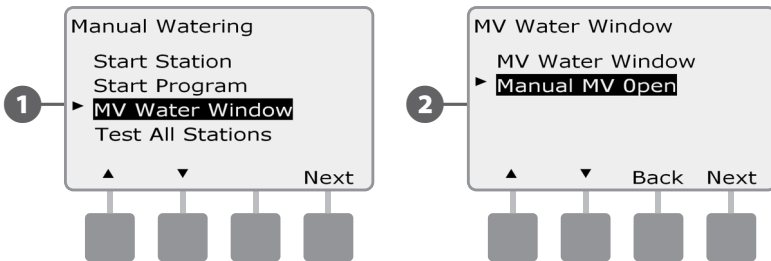

- ➌ The Manual MV Open screen appears. Press the + and – buttons to set the duration (in hours and minutes) for the MV to be open; then press Next. “MV is Open” will be briefly displayed.

- Press and HOLD buttons to accelerate settings for hours and minutes.

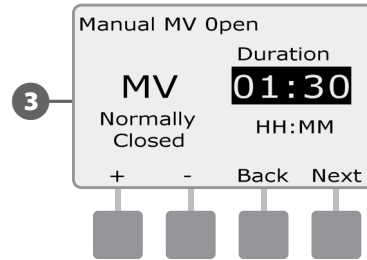

- ⚠ **NOTE:** The Manual MV Open function can also be used with normally open master valves (NOMVs). If flow sensing is installed, using this function informs the controller that a manual flow rate should be expected, eliminating high flow (SEEF) shut down.

Test All Stations

You can test all stations connected to your controller by running each of them in sequence.

Sometimes this is useful after installation, for general maintenance or as a first step in troubleshooting your system.

! **NOTE:** Only stations with programmed run times are included in the Test All Stations operation.

▶ Turn the controller dial to Manual Watering.

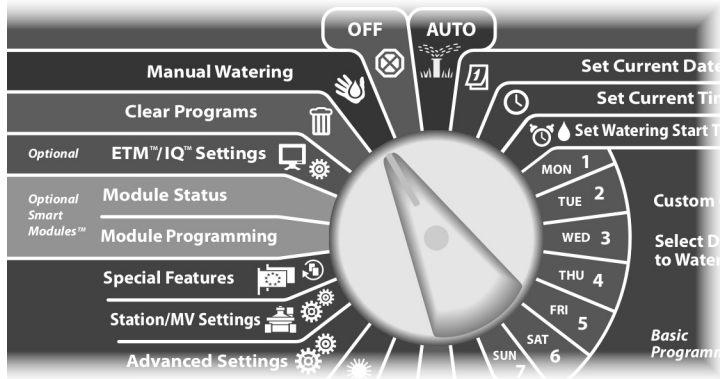

- 1 The Manual Watering screen appears. Press the Down Arrow button to select Test All Stations; then press Next.
- 2 The Test All Stations screen appears. Press the + and – buttons to adjust the Test Run Time (adjustable from 1 to 10 minutes) per station; then press Run.

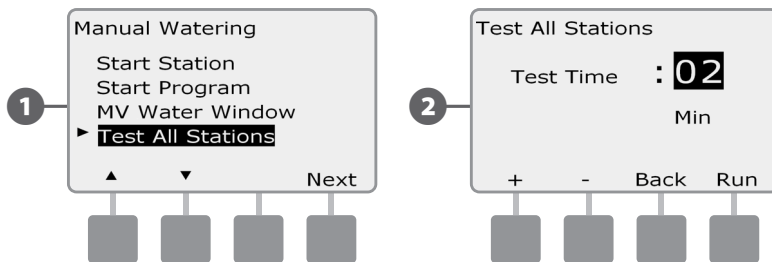

- 3 A confirmation screen appears.
- 4 Once Run is pressed, stations can be monitored and advanced by turning the dial to the AUTO position and using the Adv button. Press the + and – buttons to increase or decrease Run Time minutes for the current station.

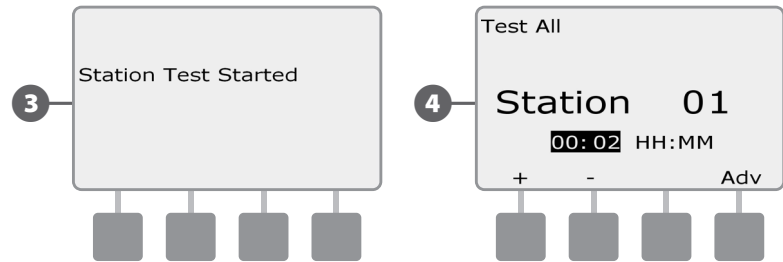

OFF

Turns off irrigation or closes the master valve.

Adjust Display Contrast

Adjust the contrast settings for the controller display for better visibility.

- ▶ Turn the controller dial to OFF.

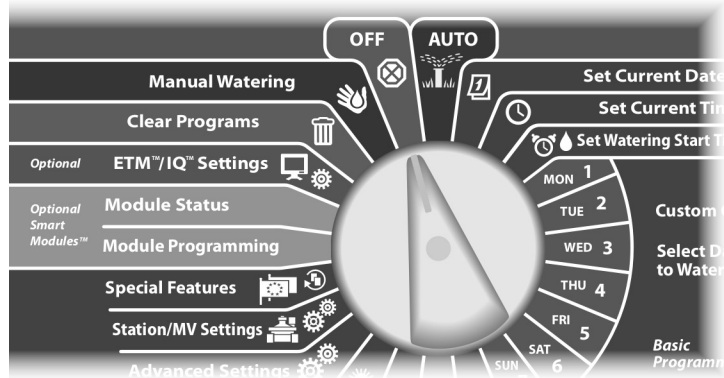

- 1 The All Watering Off screen appears and the current contrast adjustment setting will display for 10 seconds. Press the + and - buttons to adjust contrast up or down.

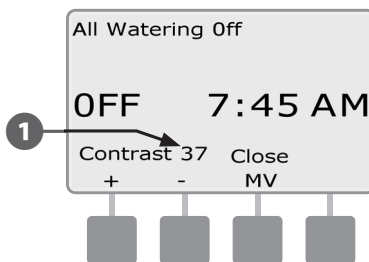

Close the Master Valve

Closes the Normally Open master valve, disabling irrigation.

CAUTION: Using the Close MV function will disable all irrigation functions.

Turn the controller dial to OFF.

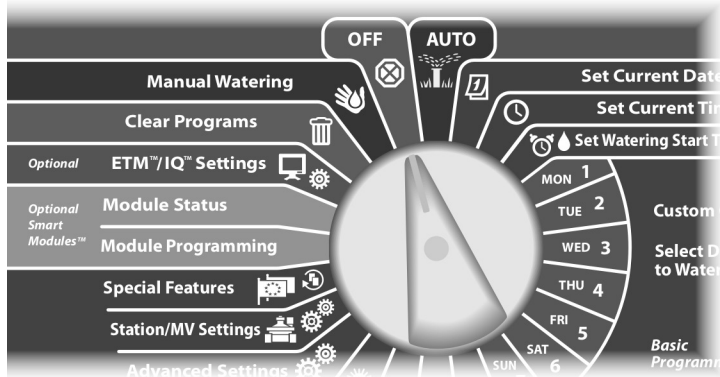

- 1 The All Watering Off screen appears. Press the Close MV button.
- 2 A confirmation screen appears. To close the normally open master valve, press and hold down the Yes button for four seconds. If you're not sure, press Back.

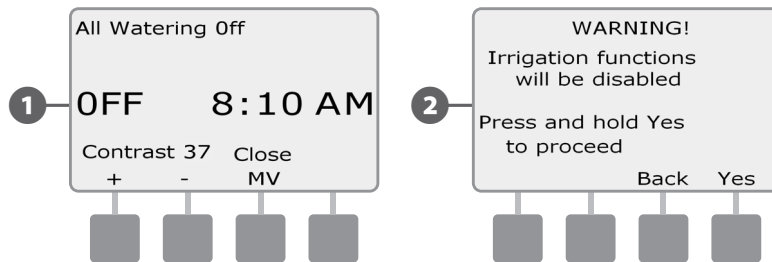

- 3 A confirmation screen appears.
- 4 The OFF dial position screen will now display the message "MV is Closed". To cancel and restore irrigation functions, turn the dial to AUTO.

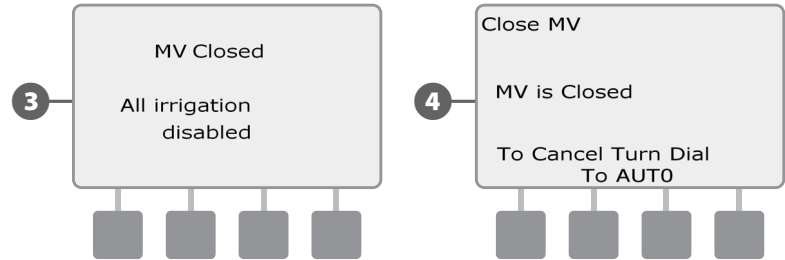

this page intentionally left blank

Section H - Installation

This section explains how to mount the ESP-LXME controller, connect the wiring, and verify proper operation.

Prepare For Installation

Installation Checklist

When installing the ESP-LXME controller for the first time, it is recommended that you complete the following steps in order.

For your convenience a check-off box is provided for each step.

- Check box contents..... Page 156
- Gather installation tools Page 157
- Select a location Page 158
- Mount ETC Receiver/Antenna Page 161
- Mount the controller Page 162
- Connect source power Page 163
- Install base and station module(s)..... Page 167
- Connect field wiring..... Page 170
- Complete controller installation..... Page 173
- Connect local weather sensor (optional) Page 172
- Connect ETC Manager cartridge Page 174
- Install local rain gauge (optional) Page 177

Check Box Contents

All components below are included with your ESP-LXME controller and are required for installation. If anything is missing, please contact your distributor before proceeding.

- 1 ESP-LXME controller and modules.
- 2 Mounting hardware (5 screws, 5 plastic wall anchors).
- 3 Controller cabinet keys.
- 4 ESP-LXME Controller Installation, Programming, & Operation Guide.
- 5 ESP-LXME Controller Programming Chart.
- 6 Controller mounting template.
- 7 Station Numbering Labels

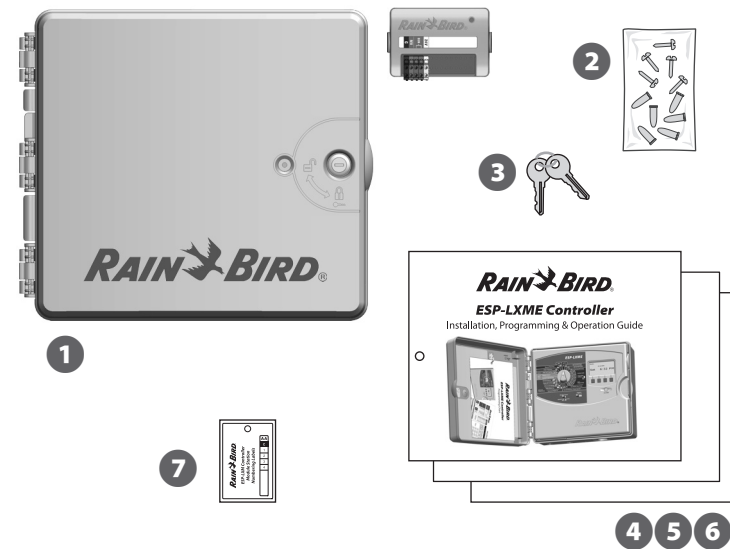

Gather Installation Tools

Before beginning installation, gather the following tools and materials:

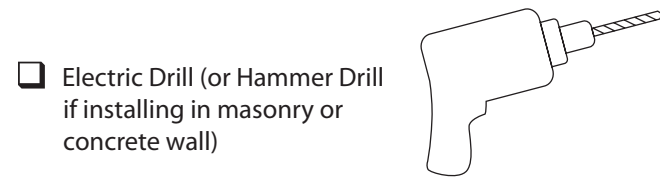
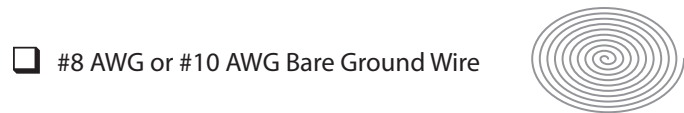
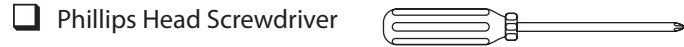
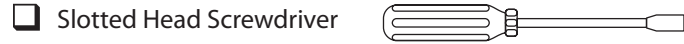

Install the Controller

The ESP-LXME controller mounts to a wall (or suitable mounting surface).

! **NOTE:** An optional metal cabinet (LXMM) and pedestal (LXMPED) are also available for the ESP-LXME controller. If you intend to use those options, follow the installation instructions for those products before installing the controller.

⚡ **WARNING:** This controller must be installed in compliance with local electrical codes.

Select Location for Controller

Select a location that:

- Is easily accessible
- Allows for comfortable viewing
- Has a flat wall surface
- Near 120 V or 230/240 V AC power source (depending on model)
- Is safe from potential vandalism
- Is outside the range of operating sprinklers

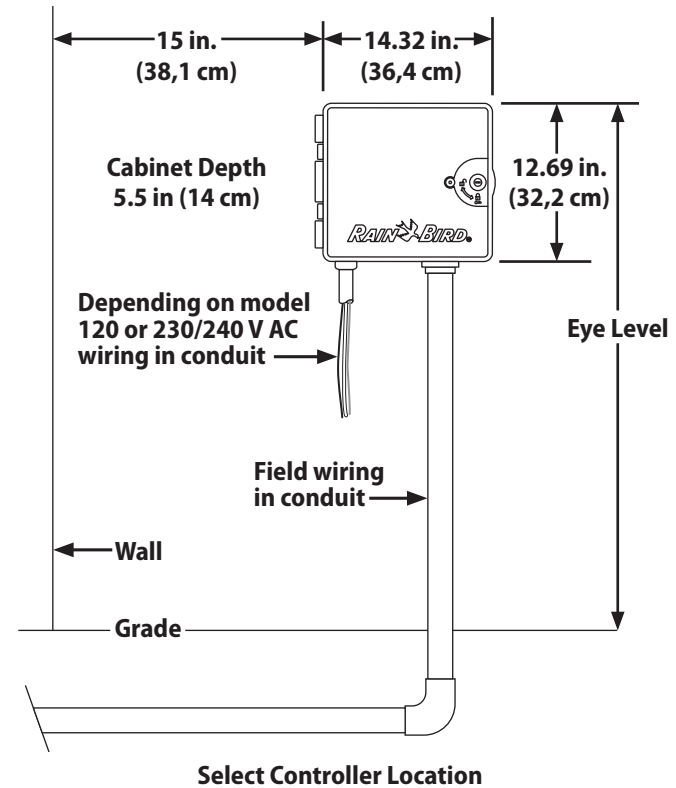

Access Controller Cabinet

Remove Cabinet Door and Front Panel

- 1 The controller comes with an outer door lock to deter vandalism and prevent unauthorized access to controller operations. If necessary, unlock the cabinet door using the supplied key.
- 2 To open the controller door: grasp the crescent-shaped handle on the right-hand-side of the outer cabinet.

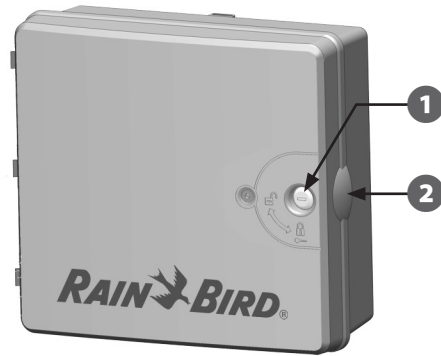

- 3 Pull it towards you to open the door, swinging it to the left.
- 4 To remove the door, carefully pull the door away from the cabinet until the door hinges separate from the plastic posts.

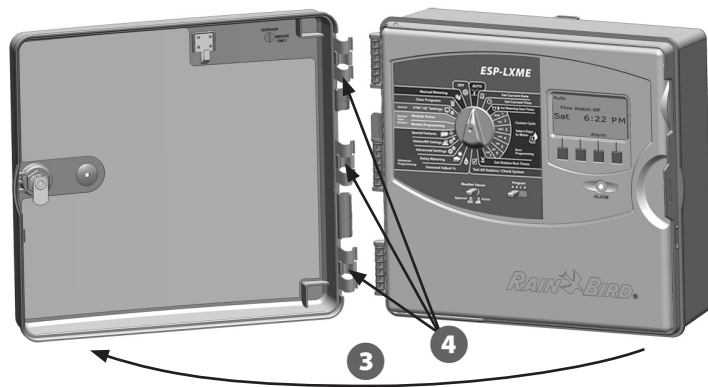

- 5 To open the controller front panel: grasp the crescent-shaped handle on the right-hand-side of the front panel.



- 6 Pull it towards you to open the front panel, swinging it to the left.

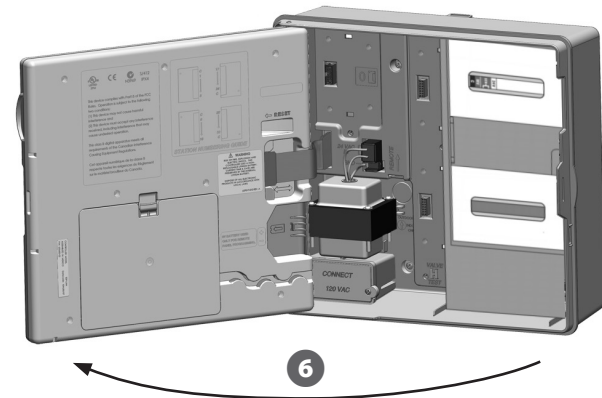

- 7 To remove the front panel: disconnect the ribbon cable from the front panel by gently pulling the connector out of the socket.

 **CAUTION:** Be careful not to bend the pins in the sockets when attaching or detaching the ribbon cable.

- 8 Rock the front panel upward and nudge the bottom corner pin out of the lower pin-hole to remove the front panel.

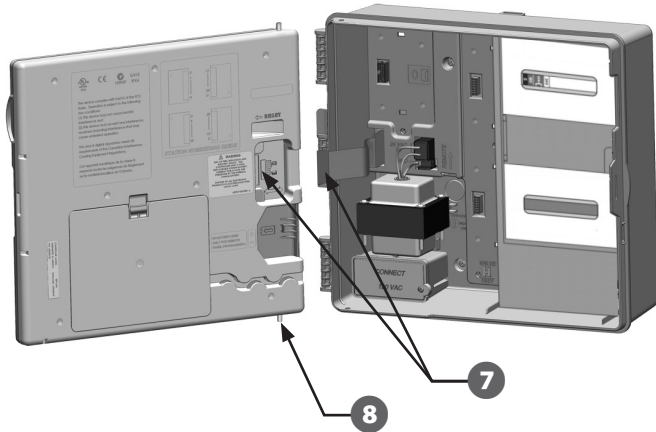

Remove Modules

Every ESP-LXME Controller ships with two modules packaged inside the cabinet, one base module (Base or Flow Smart) and one station module (SM8 or SM12). The types of modules that are included depend on the variant of ESP-LXME.

- 1 Remove both the modules and cardboard packaging from inside the controller and set the modules aside for installation later.
- 2 The top-most box contains either the Base or Flow Smart Module, with multi-color label visible through the box window.
- 3 The bottom-most box contains either an 8 or 12 Station Module, with solid blue color label visible through the box window.

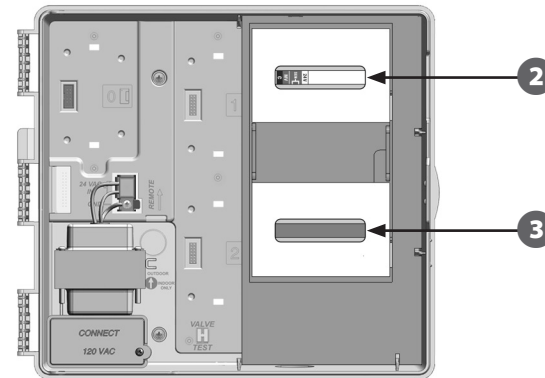

Mount the Receiver/Antenna

- 1 Using a screwdriver or other pointed tool, punch through and remove the antenna knock-out located on the top right of the controller case.

! **NOTE:** Removing the antenna knockout with a screwdriver and hammer is easier if the controller is NOT currently installed.

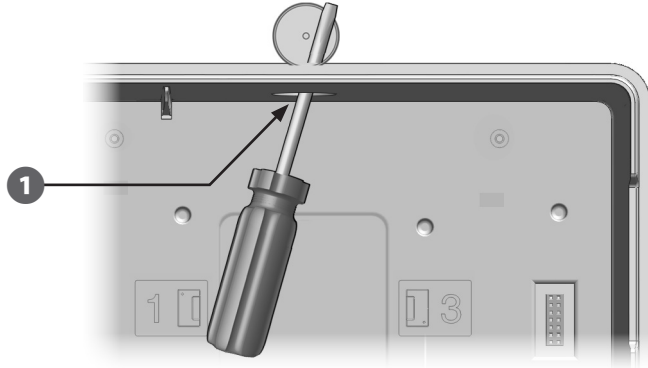

- 2 Verify the black washer (included) is in place at the base of the antenna. Route the antenna cable through the knockout and set the antenna into the hole.
- 3 Secure from the inside using the metal nut provided. Hand tighten until snug, plus additional half turn.

! **NOTE:** The metal nut should be positioned with the teeth facing upward, toward the top of the controller case.

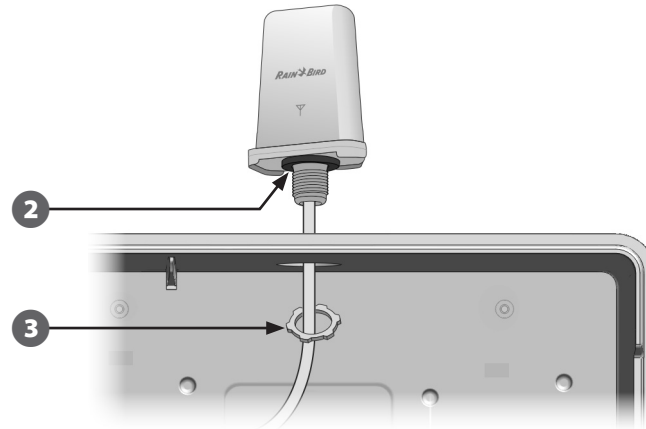

Mount Controller

- 1 Using a level, tape the mounting template to the mounting surface at approximately eye level. Make sure that at least one of the five mounting hole marks is aligned on a wall stud or other solid surface.
- 2 Use a tapping tool (or nail) and hammer to tap pilot holes through the five mounting hole marks and into the mounting surface. Then remove the template and drill holes in the mounting surface, installing wall anchors if necessary.

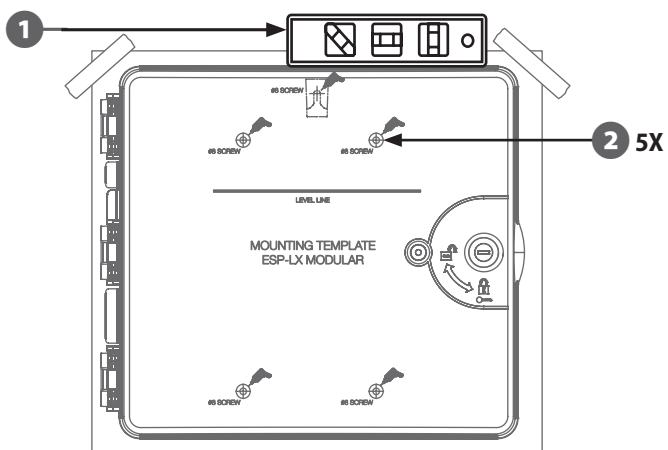

NOTE: If the controller needs to be mounted on an uneven surface like stucco, place (or install) a section of exterior plywood between the controller and the wall.

- 3 Drive the first screw into the topmost-center hole. Then hang the controller on the screw by the key-hole slot on the back of the cabinet.
- 4 Line up the controller cabinet mounting holes with the remaining pilot holes and drive the four remaining screws through the cabinet back plane into the mounting surface.

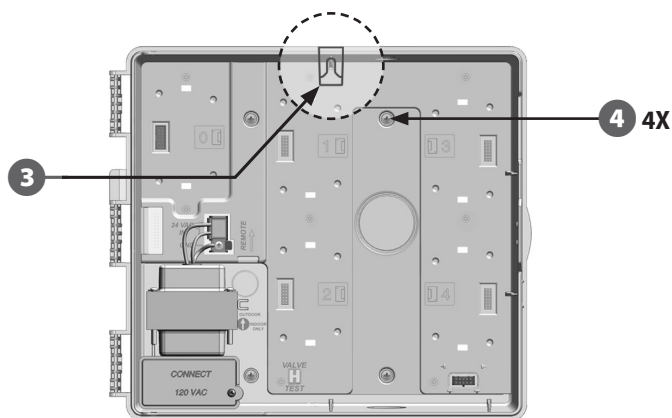

Connect Power to the Controller

Surge Protection and Grounding

The ESP-LXME controller is equipped with built-in electrical surge protection. For this system to function, you must properly ground the controller.

⚡ WARNING: The ESP-LXME controller must be properly surge protected and grounded. Doing so can help prevent damage to the controller and irrigation system and also significantly reduce troubleshooting, repair time and expense. Failure to do so could result in failure of your controller and voiding the warranty.

Ensure that all grounding devices are compliant with local electrical codes.

Connect Power Source

The ESP-LXME controller has an internal transformer that reduces supply voltage (120 VAC in U.S. models; 230 VAC in international models; 240 VAC in Australian models) to 24 VAC. You will need to connect power supply wires to the transformer's three wires. (Line, Neutral, Ground)

⚡ WARNING: Electric shock can cause severe injury or death. Make sure power supply is turned OFF before connecting power wires.

⚡ WARNING: All electrical connections and wiring runs must be made according to local building codes.

- 1 Locate the transformer wiring compartment in the lower left corner of the controller cabinet. Remove the screw on the right-hand side and pull the cover off to expose the wiring compartment.

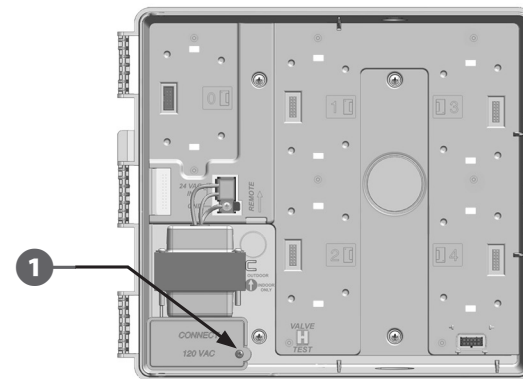

- 2 Strip the insulation from the three incoming wires to expose approximately 1/2 in (13 mm) of bare wire.
 - 3 Remove the knockout on the bottom of the cabinet below the transformer and attach a 1/2 in (13 mm) conduit fitting to the bottom entrance of the wiring compartment.
- NOTE:** 240 VAC (Australian) units do not require a conduit because the power supply cable is already installed.
- 4 Feed the three supply wires from the power source through the conduit into the wiring compartment.

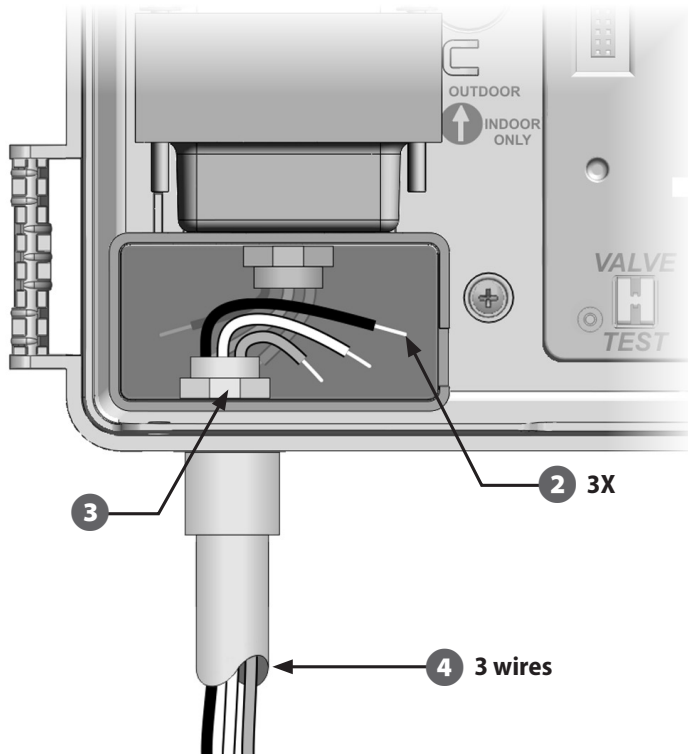

- 5 Using the provided wire nuts, connect the wires accordingly.

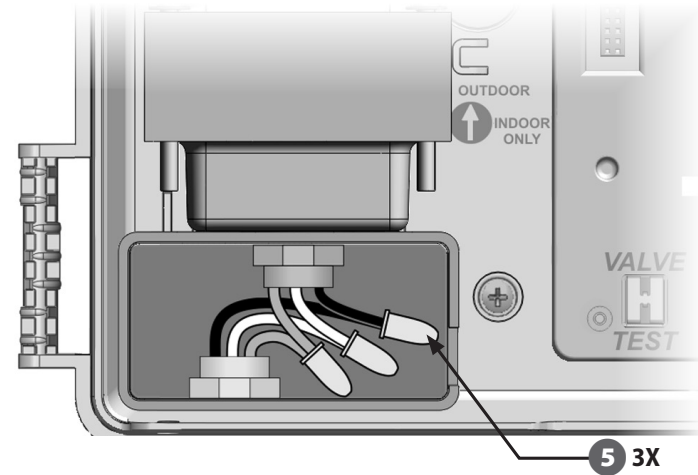

WARNING: The ground wire MUST be connected to provide electrical surge protection. You will void the controller warranty if you do not ground the controller.

Wiring Connections	
120 VAC (US)	230 VAC (International)
Black supply wire (hot) to the black transformer wire	Black supply wire (hot) to the black transformer wire
White supply wire (neutral) to the white transformer wire	Blue supply wire (neutral) to the blue transformer wire
Green supply wire (ground) to the green transformer wire	Green-with-yellow-stripe supply wire (ground) to the green-with-yellow-stripe transformer wire

- 6 Once wiring is completed, fill top of conduit with waterproof caulking to prevent insect intrusion into the controller cabinet.

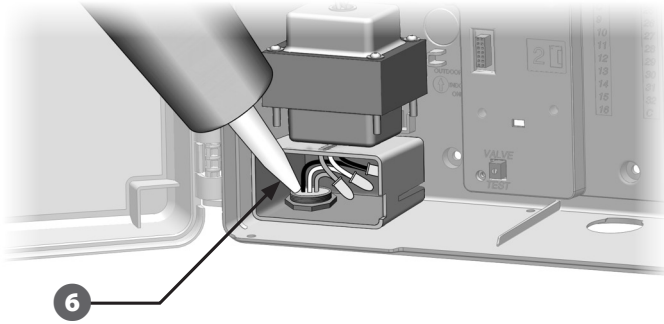

- 7 Verify that all connections are secure. Then replace the cover of the transformer wiring compartment and secure it with the screw.

Re-install Front Panel

⚡ WARNING: To prevent electrical shock, make sure all supply power is OFF before installing the front panel. Electrical shock can cause severe injury or death.

- 1 Reinstall the front panel by inserting the top corner pin into the top pin-hole; then push up and rock the bottom corner pin into the lower pin-hole.

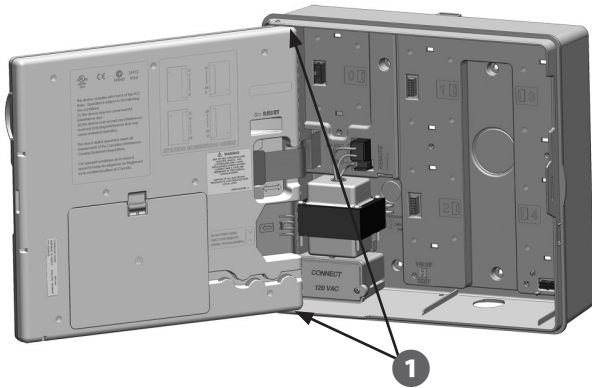

- 2 Reconnect the ribbon cable to the front panel by gently pushing the connector into the socket.

⚠ CAUTION: Be careful NOT to bend the pins in the socket.

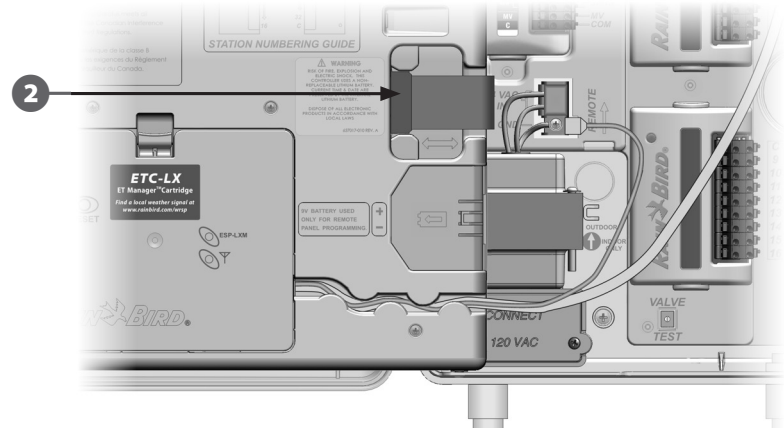

- 3 Turn on the power source.

! NOTE: The first time you power up the controller, the display will prompt you to select the language you wish to use. See Section F, Set Language for more details.

Install Modules

Install BM-LXME Base Module

Install the BM-LXME Base Module in Slot 0.

NOTE: If your ESP-LXME controller included an FSM-LXME Flow Smart Module, see Section E for installation procedures.



BM-LXME Base Module

CAUTION: Be careful not to bend the pins in the sockets when installing the module.

NOTE: The Base and Flow Smart Module include a jumper wire connecting the weather sensor (SEN) terminals. Do not remove the jumper wire unless you install a weather sensor.

1 Orient the connector on the bottom of the module with the connection socket in Slot 0 on the controller backplane.

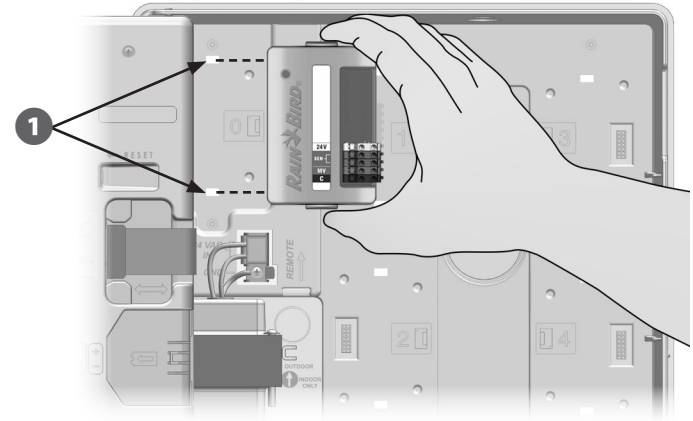

2 Carefully fasten the module onto the controller backplane, pressing firmly until it snaps into place. The red light on the module will flash on and off once if the module is installed correctly. If the light does not flash once, verify the module is seated correctly.

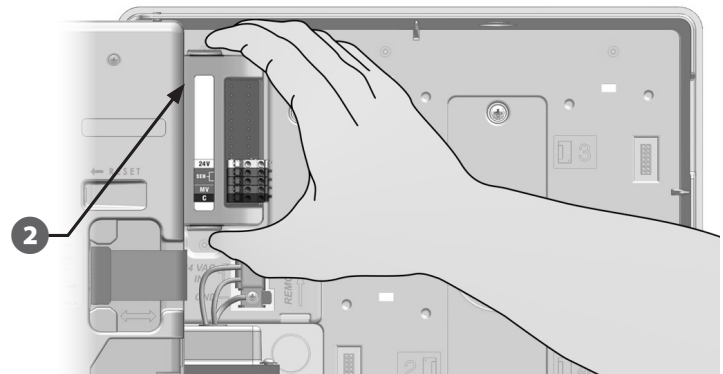

NOTE: To remove the module, press in on the (two) release buttons on either side of the module.

Install Station Module

Install the station module in Slot 1 that was included with your ESP-LXME controller. Additional station modules can be purchased separately.



ESP-LXM-SM8 Station Module



ESP-LXM-SM12 Station Module



CAUTION: Be careful not to bend the pins in the sockets when installing a module.

- 1 Orient the connector on the bottom of the station module with the connection socket in Slot 1 on the controller backplane. (An ESP-LXM-SM8 is shown.)

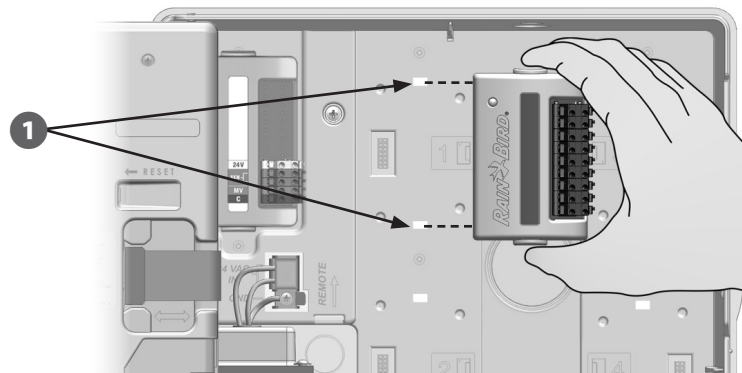

- 2 Carefully fasten the module onto the controller backplane, pressing firmly until it snaps into place. The red light on the module will flash on and off once if the module is installed correctly. If the light does not flash once, verify the module is seated correctly.

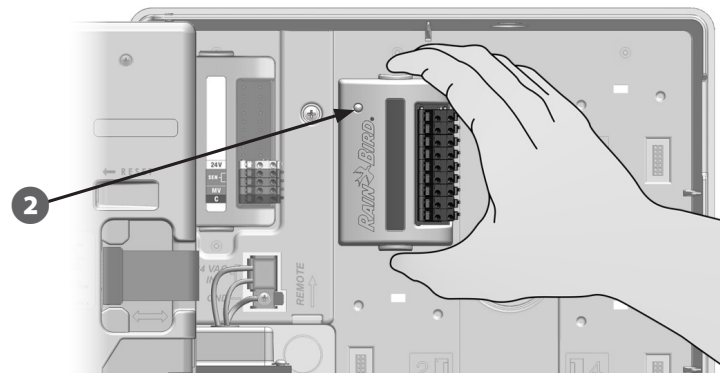

NOTE: To remove a module, press in on the (two) release buttons on either side of a module.

Dynamic Station Numbering

The ESP-LXME controller will automatically detect any new station modules that have been installed. Follow the instructions on the front panel LCD to configure a station module.

- 1 A Module Configuration screen is displayed whenever the ESP-LXM Controller detects a change in module configuration. Press Next to continue.
- 2 The Module Summary screen displays the module type detected in each module slot along with the new and old assigned station numbers. Press Accept to accept the new module configuration. (Reject will retain the current configuration.)

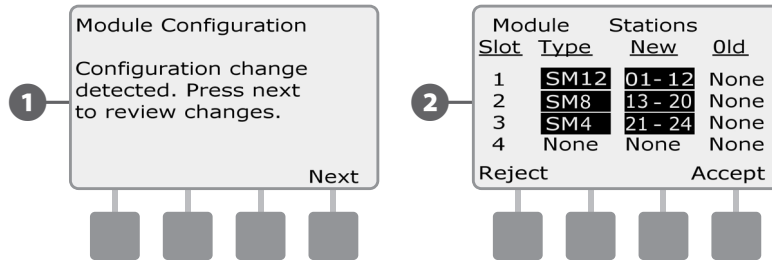

- 3 The Module Labels screen is displayed. Locate the Module Station Numbering Labels that are provided on a separate foldout sheet. Press Next to continue.
- 4 The Module Station Numbering Graphic displays a pair of letters (example: Slot 1 = Label AC) for each installed module. Find the station numbering label on the foldout sheet with the matching letter pair and place it over the blue strip on the module. Press Done to finish.

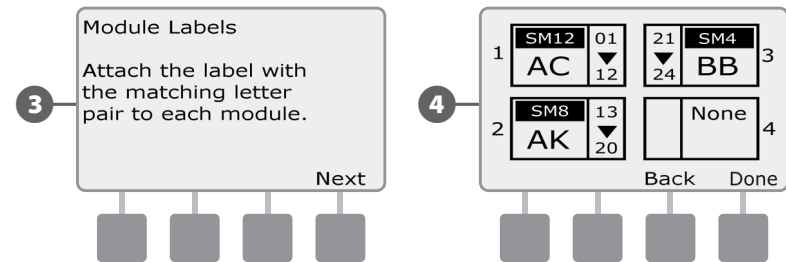

- NOTE:** The Module Status can be reviewed at any time by turning the dial to the Station/MV Settings dial position and selecting Module Status. See Module Status in Section D for details.

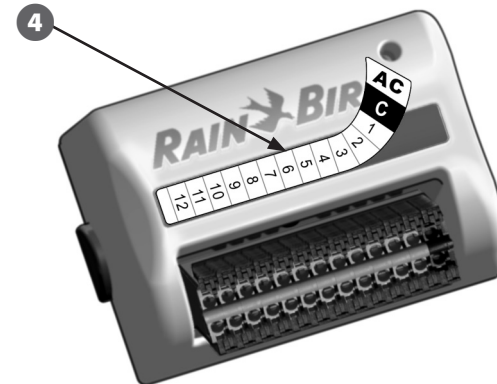

Connect Field Wiring

Connect Valve Wires

Field wires for valves are connected to module terminals using quick connectors. Press the swing arm of the appropriate terminal and insert the wire. When you release the spring arm, the clamp will hold the wire.

⚠ WARNING: You must use special precautions when valve wires (also known as station or solenoid wires) are located adjacent to or share a conduit with other wires, such as wires used for landscape lighting, other “low voltage” systems or other “high voltage” power. Be sure to separate and insulate all conductors carefully taking care not to damage wire insulation during installation. An electrical “short” (contact) between the valve wires and another source of power can damage the controller and create a fire hazard.

- 1 Locate (or remove) the large knockout on the bottom of the controller cabinet. Attach a conduit fitting to the bottom of the cabinet; then attach conduit to the fitting.
- 2 Feed the field wires through the conduit and into the controller cabinet.

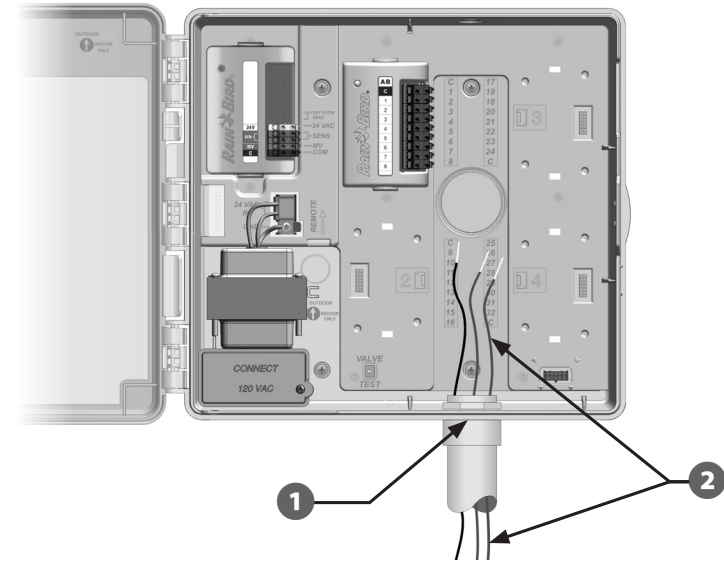

- 3 Field wires for valves are connected to module terminals using quick connectors. Press the swing arm of the appropriate terminal and insert the wire. When you release the spring arm, the clamp will hold the wire.

- 4 Strip the wire jacket back by a maximum of 1/2 inch (12 mm) and connect each valve wire to one of the numbered terminals on a station module.
 - 5 Connect the common wire(s) to any one of the COM terminals on the controller. Wires used to connect the valves must be code-approved for underground installation.
- !** **NOTE:** Complete the following step only if your system uses a master valve or a pump start relay. The controller does not provide main power for a pump.
- 6 Connect the master valve or pump start relay wiring to the MV and COM terminals.

- 7 Once wiring is completed, fill top of conduit with waterproof caulking to prevent insect intrusion into the controller cabinet.

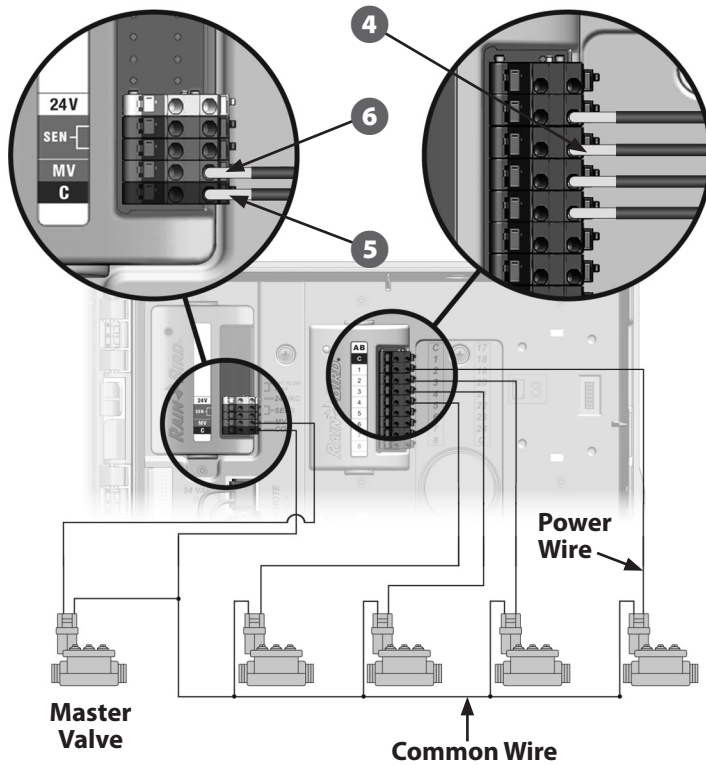
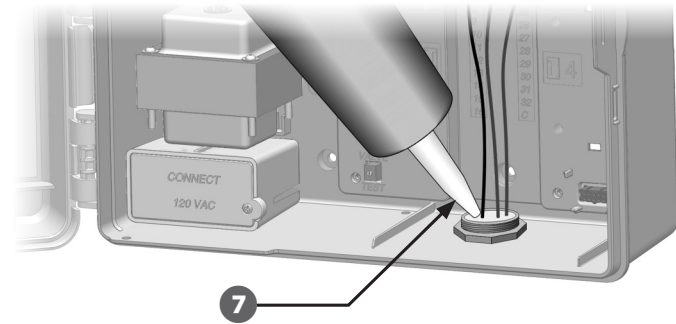

Connect Local Weather Sensor

The ESP-LXME can accept input from a single weather sensor wired directly to the controller or through a wireless receiver.

A local weather sensor can be bypassed with the sensor bypass switch on the controller front panel.

To Enable a Local Weather Sensor:

- 1 On the controller front panel, slide the Weather Sensor switch to Active.

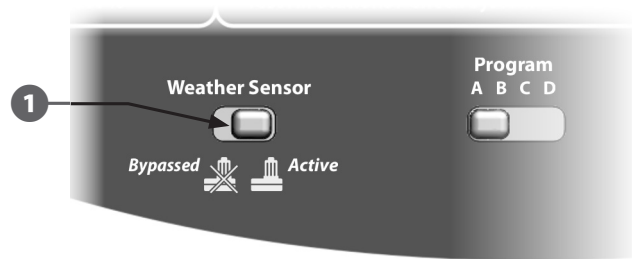

NOTE: Follow the sensor manufacturer's instructions to correctly install and make wire connections to the sensor. Ensure the sensor installation is in compliance with all local codes.

To Connect a Wired Local Weather Sensor:

- 1 Run continuous sensor wire from the weather sensor to the ESP-LXME controller.
- 2 Route wire through knockout on the bottom of the controller.
- 3 Remove the yellow jumper wire (if present). Connect the two sensor wires to the sensor (Sen) inputs. When finished, tug gently on the wires to make sure the connections are tight.

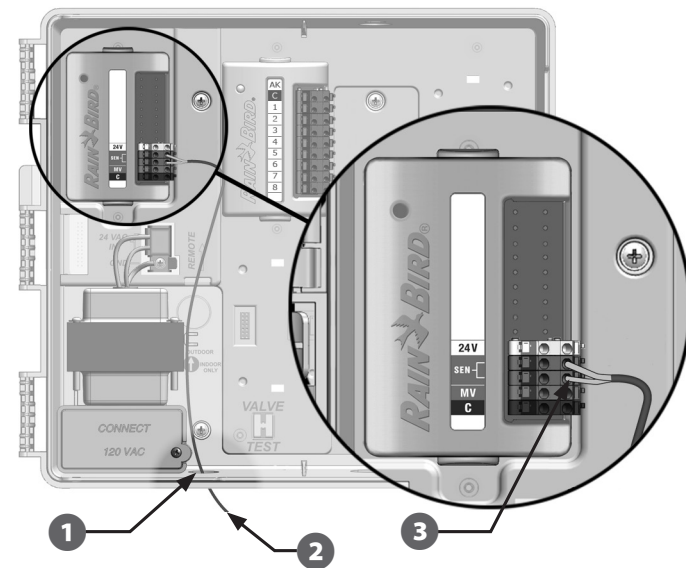

To Connect a Wireless Local Weather Sensor:

- 1 Run wire from the wireless receiver to the ESP-LXME controller.
- 2 Route wire through knockout on the bottom of the controller.
- 3 Remove the yellow jumper wire (if present). Connect the two sensor wires to the sensor (Sen) inputs, the power wire to the 24V input, and the common wire to the common (C) input. When finished, tug gently on the wires to make sure the connections are tight.

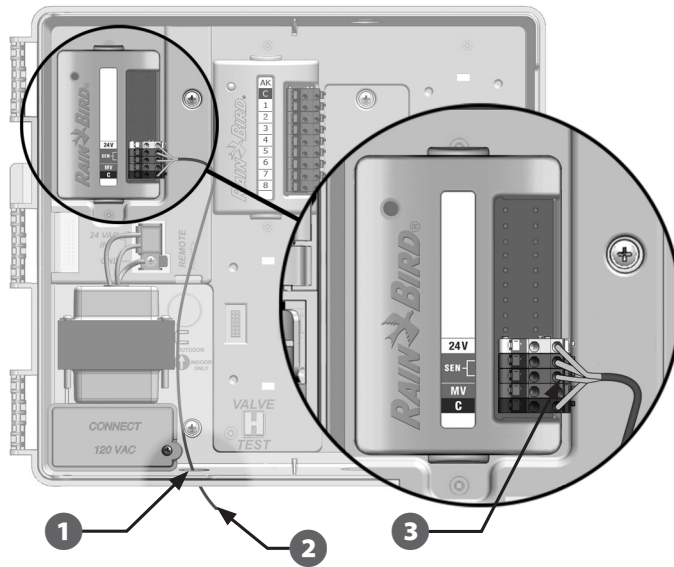

! **NOTE:** Ensure that the configuration for your controller and irrigation programs are set up correctly for your sensor. For example, if one of your programs is set up to manage your landscape lighting you may want to ensure that it's stations ignore input from a local weather sensor. See Section D, Weather Sensor, for more details.

Complete Controller Installation

Install Front Door

- 1 Line up the three door hinges with the plastic posts on the controller.
- 2 Press the hinges onto the posts until the front door snaps into place.

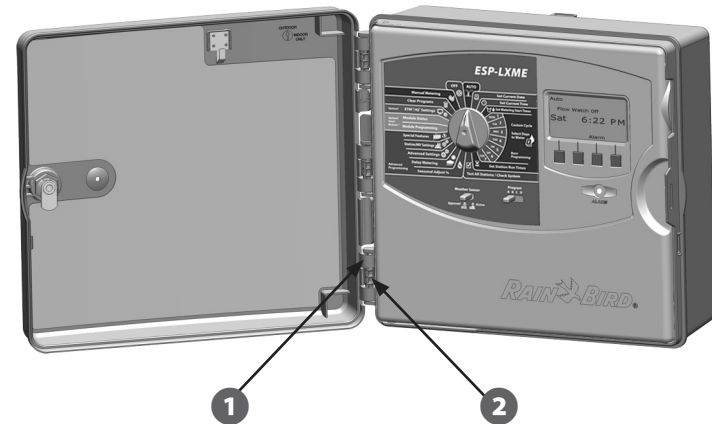

Verify Field Installation

Once some or all valves have been wired and programmed into the ESP-LXME controller you can check the electrical portion of the installation even if water is not available to test the valves.

If water is available and you would like to test some or all of your stations, the easiest way to do so is by using the Test All Stations feature of the controller. See Section C, Test All Stations for more details.

Connect the ET Manager Cartridge

Overview

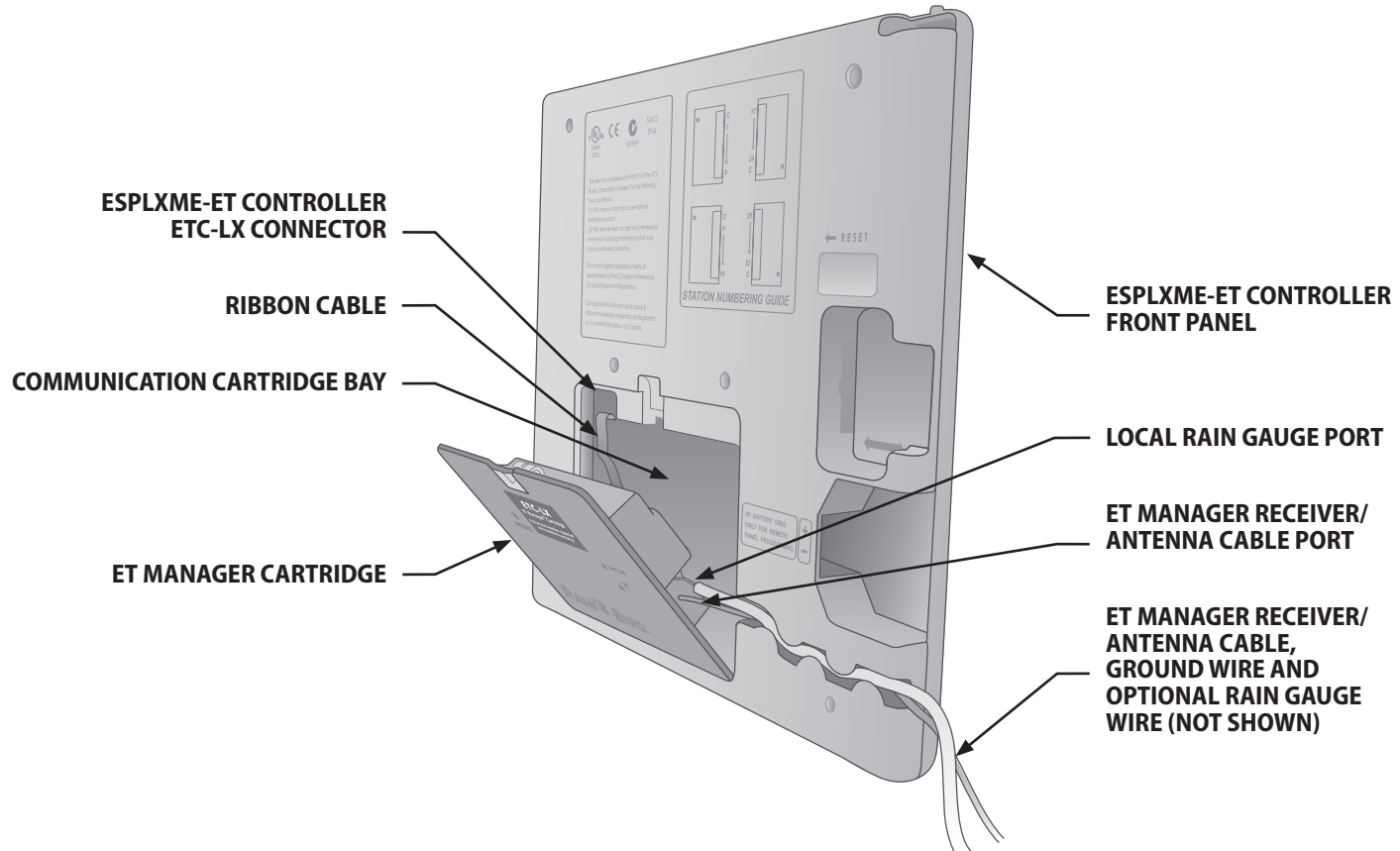

Connect Cartridge Cables

- 1 Prior to beginning the installation process, turn the dial on the front of the LX controller to ETMTM/IQTM or ETMTM/IQTM/PBCTM Settings.
- 2 Press down on the top-latch of the ET Manager cartridge and remove it from the back of the controller front panel.

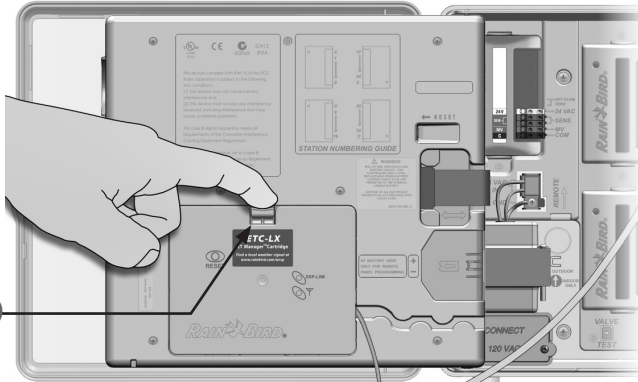

- 3 Plug the ET Manager Receiver/Antenna Cable's RJ45 connector (male) into the jack (female) in the back of the ET Manager Cartridge. Ensure a secure fit when you here it "click" into place.

CAUTION: This connector can only go in one way. Ensure that the ridges on the plug match the slots in the receptacle.

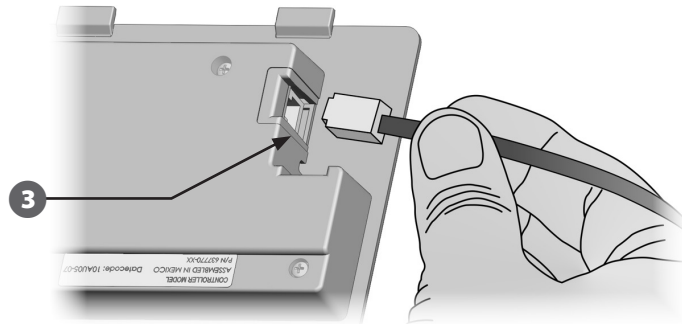

- 4 Connect the green and yellow ground wire to the grounding post on the left side of the controller backplane.

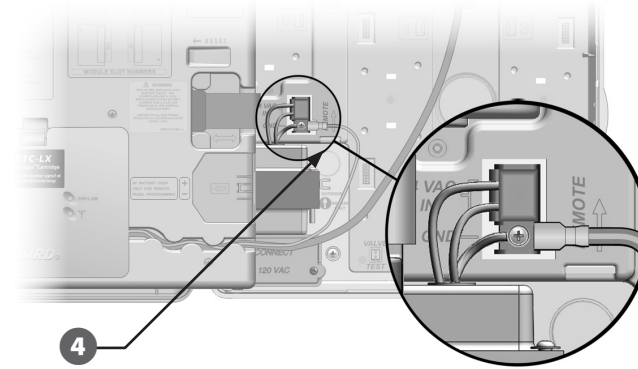

- 5 Ensure the ETC Cartridge ribbon cable is connected to the knife-edge connector located at the top-left corner inside the cartridge bay of the controller front panel.

CAUTION: This connector can only go in one way. Ensure that the RED edge of the ribbon cable is toward the LEFT side of the opening.

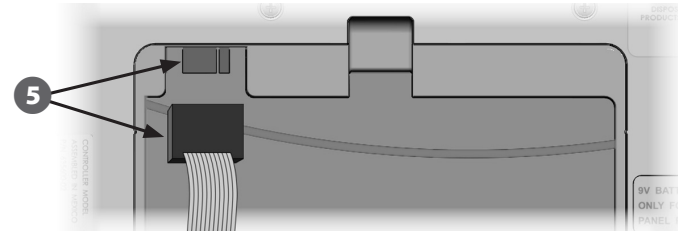

- 6** Orient the cartridge so that the two bottom hinges fit into the hinge openings at the bottom of the cartridge bay. Then gently swing the cartridge up into place, snapping the top-latch.

! **NOTE:** Position the wires so that they match up with the cable routing channel in the front panel.

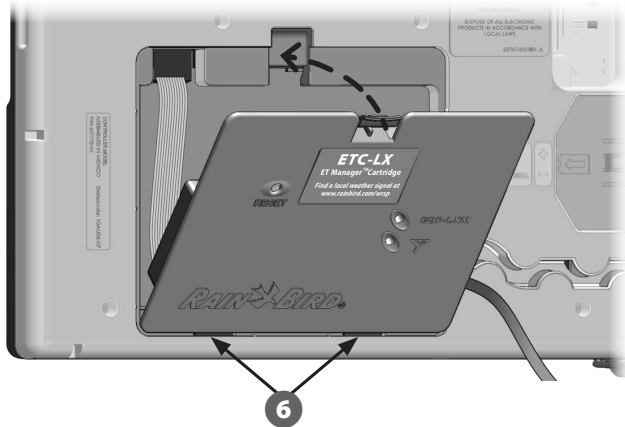

- 7** Route the Antenna Cable and ground wire through the cable channel on the back of the controller front panel.

! **CAUTION:** Ensure that the antenna cable and ground wire do not contact the transformer directly. Heat from the transformer may damage the insulation.

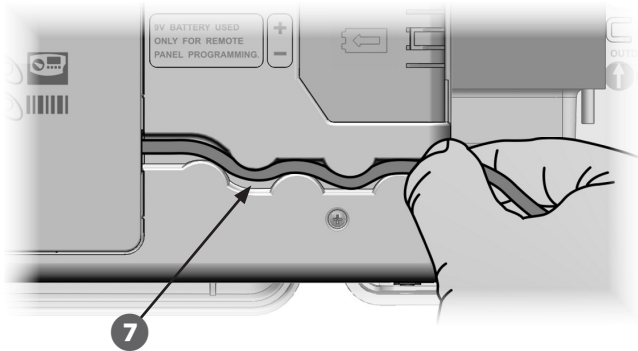

! **NOTE:** When connecting the ET Manager Cartridge, the front panel may display a Warning with a prompt to select OK to upgrade the controller. Select OK, and a note appears that reads "The display will be blank for approximately 3 minutes". Do not power down the controller until the firmware flash has concluded. When complete, factory defaults will load and the screen will display **Communications None Installed** until the ET Manager Receiver is connected to the ET Manager Cartridge.

- 8** Close the front panel.

Rain Gauge Installation

Install the Local Rain Gauge

Follow the Local Rain Gauge (ETM-RG) Installation Guide for proper mounting of an optional Rain Gauge.

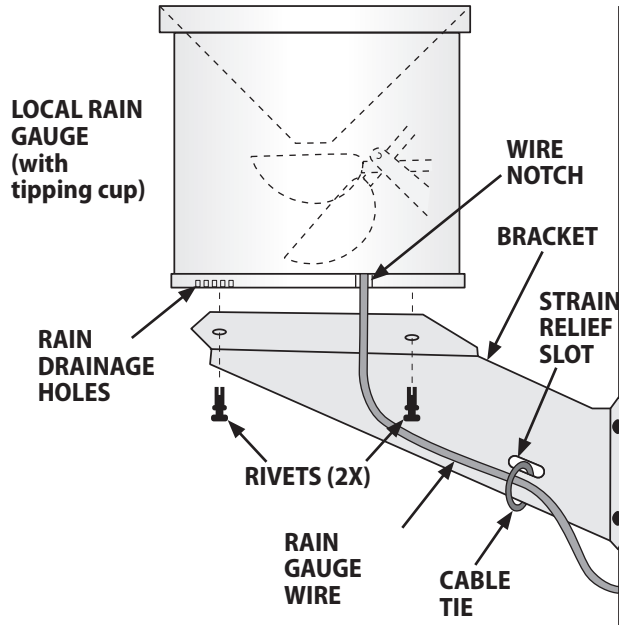

Connect the Local Rain Gauge

After the Rain Gauge is mounted properly, follow the steps below to connect the gauge to the cartridge.

! **NOTE:** When using the Local Rain Gauge (ETM-RG), the ET Manager Cartridge must be programmed with the Rain Source set to "ETM-RG". See the Rain Source section for programming instructions.

1 Unlatch the ET Manager Cartridge by pressing down on the latch and pulling forward.

2 Route the Rain Gauge wires through the knock-out on the bottom of the controller.

3 Use the flat-head screwdriver (included) to connect the Rain Gauge wires to the blue 2-wire terminal (included as a separate piece with the ET Manager Cartridge – not included with the ETM-RG). Give the wires a gentle tug to make sure they are securely connected.

4 Plug the blue 2-wire terminal with wires connected back into the ET Manager Cartridge.

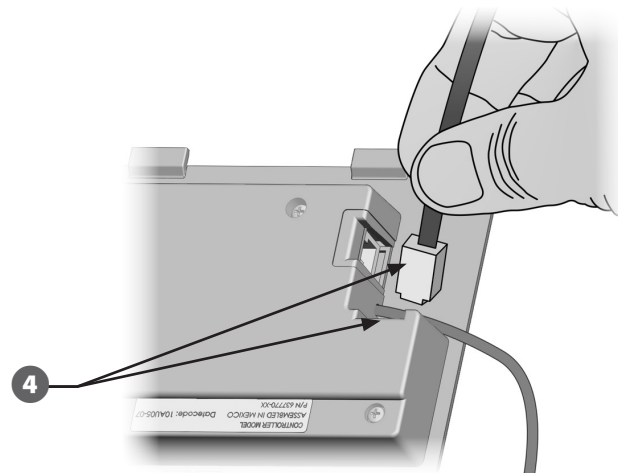

5 Insert the ET Manager Cartridge into the cartridge bay bottom edge first. Swing the top of the cartridge toward the front panel and push into place, ensuring that the thumb latch snaps securely into place.

6 Press the Rain Gauge wire firmly into the cable routing channel with the green/yellow ground wire, and the ET Manager Receiver/Antenna Cable.

! **NOTE:** If the ribbon cable becomes detached, re-attach with the RED edge of the ribbon cable toward the LEFT side of the opening.

this page intentionally left blank.

Appendix

Irrigation Amount and Station Run Times

Irrigation Amount

The Irrigation Amount represents how many inches (or mm) of water is applied to your landscape during each program start time. The Total Irrigation Amount is the Irrigation Amount setting multiplied by the number of start times. This is the amount of water that needs to evaporate before the ET Manager will allow watering to start again. The optimum Total Irrigation Amount is based on your soil type and the plant's root depth (refer to the table in the Total Irrigation Amount section). Each program has its own Irrigation Amount setting to accommodate different landscape watering needs.

Peak Season ET Method

When the ET Manager is being installed on an established site that already has a schedule, the 'Peak Season ET' method can be used to determine the Total Irrigation Amount. This method requires that the irrigation schedule be set to peak season watering. The next step is to determine what the average peak season ET value is for the area, which can be found by looking at the Historical ET settings and finding the highest value (typically July or August). Then multiply the average peak season ET value by the typical number of days between watering during the peak season schedule. The result is your Total Irrigation Amount.

! **NOTE:** This method should be used before the watering days and run times are set.

Peak Season ET Method Example

If a site has typically watered every other day during the peak of the season, and the Historical ET Values for that time of the year were 0.22, then the Total Irrigation Amount for the site is 0.44 (0.22 x 2 days). Change the setting for all available watering days to ON as the ET Manager will now determine which days to water.

! **NOTE:** Keep in mind that the Total Irrigation Amount needs to be divided by the number of start times in the program before entering the value for the setting.

Total Irrigation Amount

Run time settings programmed in the sprinkler controller correspond to Irrigation Amount settings in the ET Manager.

Soil Type	Estimated Total Irrigation Amount (inches)					
	Root Depth (inches)					
	2	4	6	8	12	18
Sand	0.02	0.05	0.07	0.10	0.14	0.22
Fine Sand	0.07	0.14	0.22	0.29	0.43	0.65
Loamy Sand	0.08	0.17	0.25	0.34	0.50	0.76
Sandy Loam	0.12	0.24	0.36	0.48	0.72	1.08
Sandy Clay	0.16	0.32	0.48	0.64	0.96	1.44
Loam	0.17	0.34	0.51	0.68	1.02	1.53
Sandy Clay Loam	0.15	0.30	0.45	0.60	0.90	1.35
Silty Loam	0.20	0.40	0.60	0.80	1.20	1.80
Clay Loam	0.20	0.40	0.60	0.80	1.20	1.80
Silt	0.17	0.34	0.51	0.68	1.02	1.53
Silty Clay Loam	0.20	0.40	0.60	0.80	1.20	1.80
Silty Clay	0.13	0.26	0.38	0.51	0.77	1.15
Clay	0.09	0.18	0.27	0.36	0.54	0.81

Station Run Time Settings

- 1 Use the ET Manager Scheduler software found on the ET Manager Resource CD to determine all settings for your ET Manager Cartridge and ESPLXD-ET Controller. The scheduler software requires site information such as: root depth, soil type, and sprinkler type, nozzle size and/or type, pressure, and spacing information to calculate the precipitation rate of each zone. Catch can collections can also be entered into the scheduling software to calculate your precipitation rate and distribution uniformity.
- 2 Use the sprinkler head manufacturer's expected precipitation rate (typically expressed in inches per hour). Perform this calculation for each zone to determine the setting for each program:

$$\text{Precip. Rate} \times \text{System Efficiency (80\%=0.8)} \times \text{Run Time (min)} \div 60 = \text{Irrigation Amount}$$

- 3 Perform a Catch Can Test for each valve by placing "cans" in various locations throughout the zone, then run the zone for the entire scheduled run time. Measure the amount of water in each "can" and average the amounts. This average measurement is your Irrigation Amount.

! **NOTE:** Instructions on how to conduct the test can be found in the ET Manager Scheduler Help Files).

Program Station Run Times

Run times must be set to apply the same amount of water as the Irrigation Amount setting in the ET Manager.

Precipitation Rate (inches per hour)	Irrigation Amount (inches)		
	0.35"	0.50"	0.65"
Station Run Times (minutes)			
2.00	11	15	20
1.75	12	17	22
1.50	14	20	26
1.25	17	24	31
1.00	21	30	39
0.90	23	33	43
0.80	26	38	49
0.70	30	43	56
0.60	35	50	65
0.50	42	60	78
0.40	53	75	98

Typically Spray Heads (rows 1-4)
Typically Rotors (rows 5-9)

Moisture Level Example

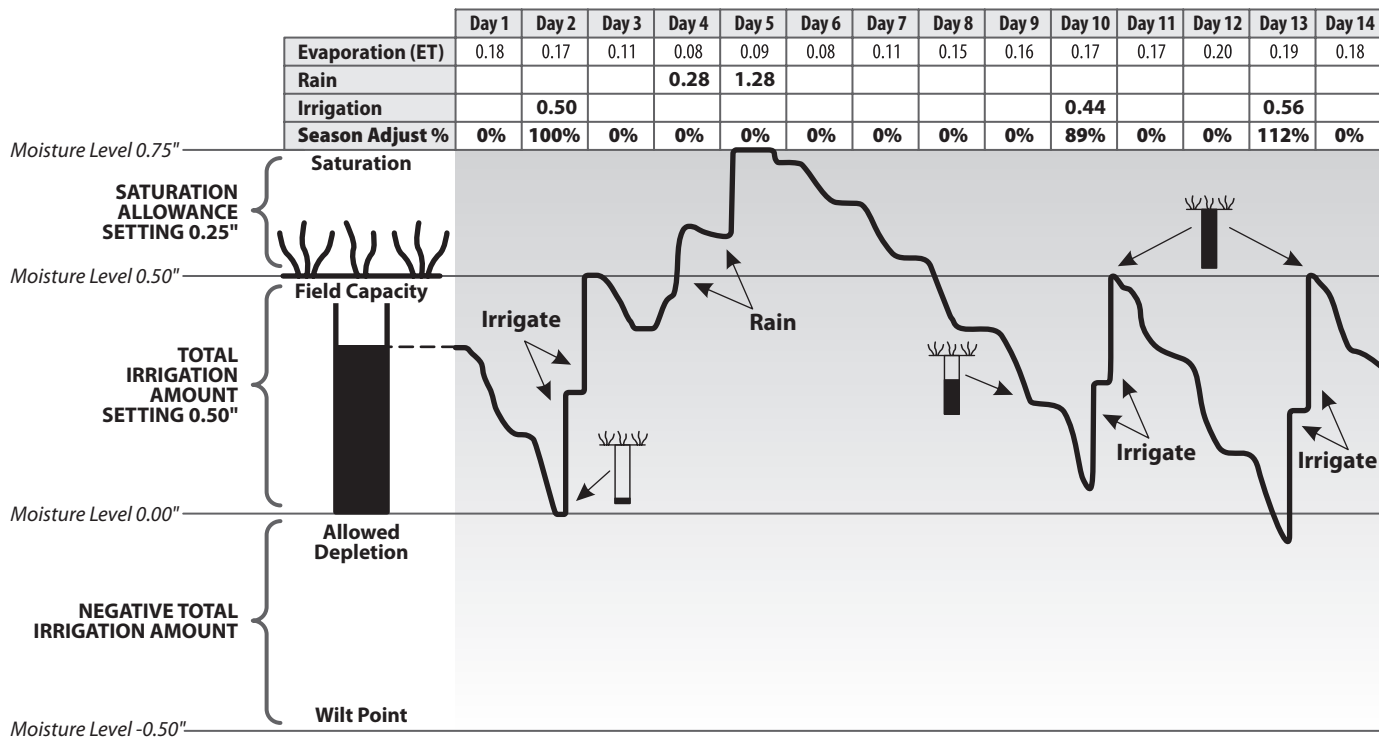

ET Manager Cartridge Default Settings

Irrigation Control	
Irrigation Amount	PGM A: NON-ET
	PGM A: NON-ET
	PGM A: NON-ET
	PGM A: NON-ET
Landscape Adjustment %	PGM A: 100%
	PGM A: 100%
	PGM A: 100%
	PGM A: 100%
Run Time Limits	Minimum Run Time: 80%
	Maximum Run Time: 120%

System Settings		
Weather Region	1	
Rain Source	Signal	
Signal Provider Code	0	
Effective Rain	Max Hourly Rain	0.25"
	Saturation Allowance	PGM A: 0.10"
		PGM A: 0.10"
		PGM A: 0.10"
ET Source	Signal	
Elevation	1000'	
Wind Adjust	100%	
Units	English	
Signal Kc	Use	
Historical ET (Jan-Dec)	0"	

Weather Interrupts	
Rain 1 Hr	0.15"
Rain 24 Hr	0.30"
Temperature	32 F
Wind	20 mph

ET Manager Menu Tree

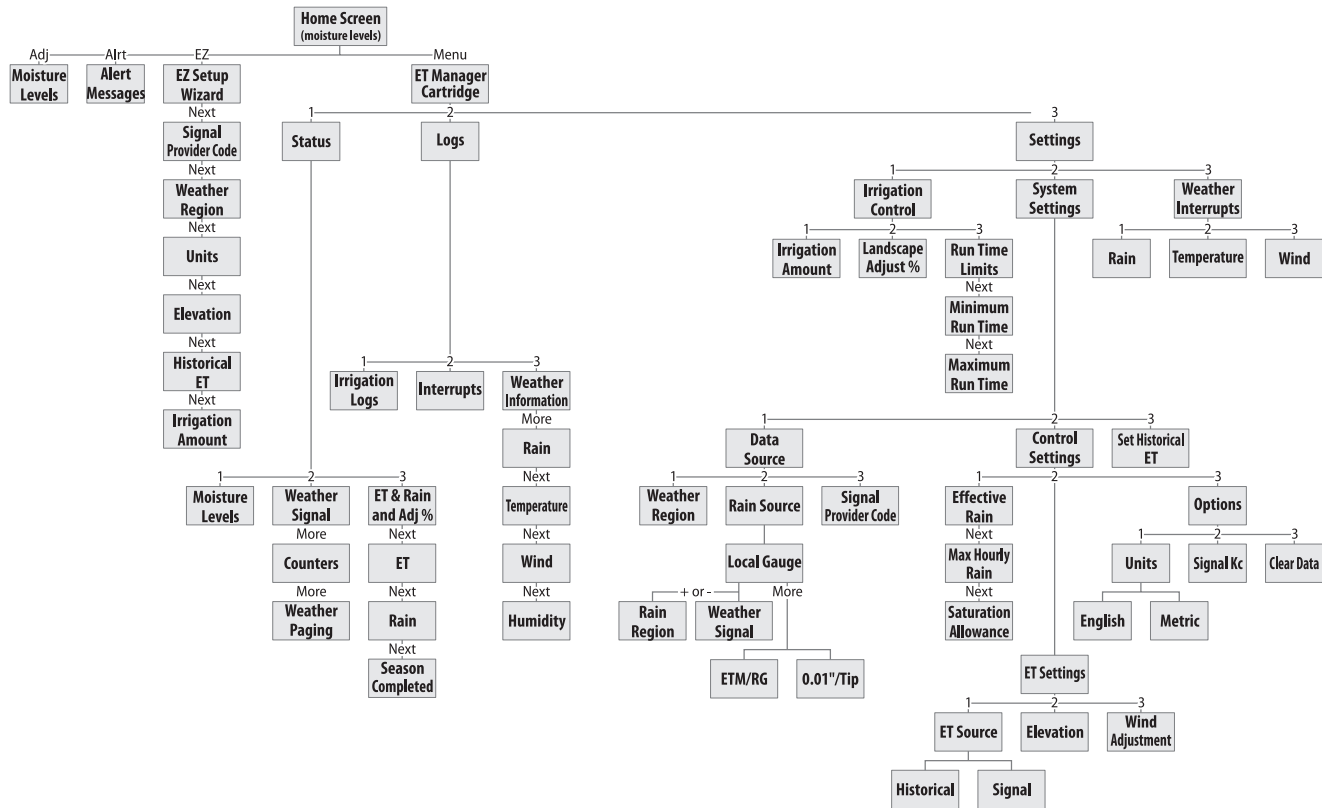

Test Cases

Landscape Parameter	Zone #1	Zone #2	Zone #3	Zone #4	Zone #5	Zone #6
Soil Texture						
Slope						
Exposure						
Root Zone Working Water Storage (RZWWS)						
Vegetation						
Crop (Turf) Coefficient (K)						
Landscape Coefficient (K)						
Irrigation System						
Precipitation Rate (PR)						
Estimated Application Efficiency						
Gross Area						

Test Cases

Controller Setting	Zone #1	Zone #2	Zone #3	Zone #4	Zone #5	Zone #6
WRSP Signal Code	A: 000, B: 000, C: 000, D: 000, E: 000, F: 000, G: 000, H: 000, I: 000, J: 000	A: 000, B: 000, C: 000, D: 000, E: 000, F: 000, G: 000, H: 000, I: 000, J: 000	A: 000, B: 000, C: 000, D: 000, E: 000, F: 000, G: 000, H: 000, I: 000, J: 000	A: 000, B: 000, C: 000, D: 000, E: 000, F: 000, G: 000, H: 000, I: 000, J: 000	A: 000, B: 000, C: 000, D: 000, E: 000, F: 000, G: 000, H: 000, I: 000, J: 000	A: 000, B: 000, C: 000, D: 000, E: 000, F: 000, G: 000, H: 000, I: 000, J: 000
Rainfall Source						
Irrigation Amount for each Program						
Run Time for each Station						
Cycle+Soak Time for each Station						
Day Cycle for each Program						
Start Time for each Program						

Rain Bird Support

Rain Bird ET Manager Hotline

(5:00 a.m. to 5:00 p.m. Pacific time)

1-877-351-6588 (U.S. and Canada only)

www.rainbird.com/etmanager

Rain Bird Technical Services Hotline

(5:00 a.m. to 5:00 p.m. Pacific time)

(800) 247-3782 (800-BIRD-SVC) (U.S. and Canada only)

Rain Bird Specifications Hotline

(800) 458-3005 (U.S. and Canada only)

Rain Bird Corporation

6991 East Southpoint Road, Tucson, AZ 85756

Phone: (520) 741-6100 Fax: (520) 741-6522

Visit us at www.rainbird.com

Declaration of Conformity

Application of Council Directive: 2004/108/EC

**Standards To Which
Conformity Is Declared:** EN55014-1: 2001 Class B
EN55022 Radiated Emissions
EN55022 Conducted Emissions
EN61000-3-2
EN61000-3-3
EN55014-2: 2001
EN61000-4-2
EN61000-4-3
EN61000-4-4
EN61000-4-5
EN61000-4-6
EN61000-4-8
EN61000-4-11

Manufacturer's Name: Rain Bird Corporation
Manufacturer's Address: 9491 Ridgehaven Court
San Diego, CA 92123
619-671-4048

Equipment Description: Irrigation Controller

Equipment Class: Requirements for household
appliances, electric tools and
similar apparatus

Model Numbers: ESP-LXME

*I the undersigned, hereby declare that the equipment specified
above conforms to the above Directive(s) and Standard(s).*

Place: Tucson, AZ USA

Signature: 

Full Name: Ryan L. Walker

Position: Director

Regulatory Information

This equipment has been tested and found to comply with the limits for a Class B digital device, pursuant to Part 15 of the FCC Rules. These limits are designed to provide reasonable protection against harmful interference in a residential installation.

This equipment generates, uses, and can radiate radio frequency energy and, if not installed and used in accordance with the instructions, may cause harmful interference to radio communications. However, there is no guarantee that interference will not occur in a particular installation.

If the equipment does cause harmful interference to radio or television reception, which can be determined by turning the equipment off and on, the user is encouraged to try to correct the interference by the following measures:

- Reorient or relocate the receiving antenna.
- Increase the separation between the equipment and the receiver.
- Connect the equipment into an outlet on a circuit different from that to which the receiver is connected.
- Consult the dealer or an experienced radio/TV technician for help.

Changes or modifications not expressly approved by Rain Bird Corporation could void the user's authority to operate the equipment.

This product was FCC certified under test conditions that included the use of shielded I/O cables and connectors between system components. To be in compliance with FCC regulations, the user must use shielded cables and connectors and install them per instructions.



RAIN BIRD CORPORATION
6991 E. Southpoint Road
Tucson, AZ 85756

© 2012 Rain Bird Corporation

® "Rain Bird", "SimulStations", "FloManager", "FloWatch", "FloZone" and "Cycle+Soak"
are registered trademarks of Rain Bird Corporation. All rights reserved.

www.rainbird.com