



en

INSTALLATION AND OPERATIONS MANUAL COMPACT LOW PROFILE RAPID SHIP (CLPRS) PUMP STATION

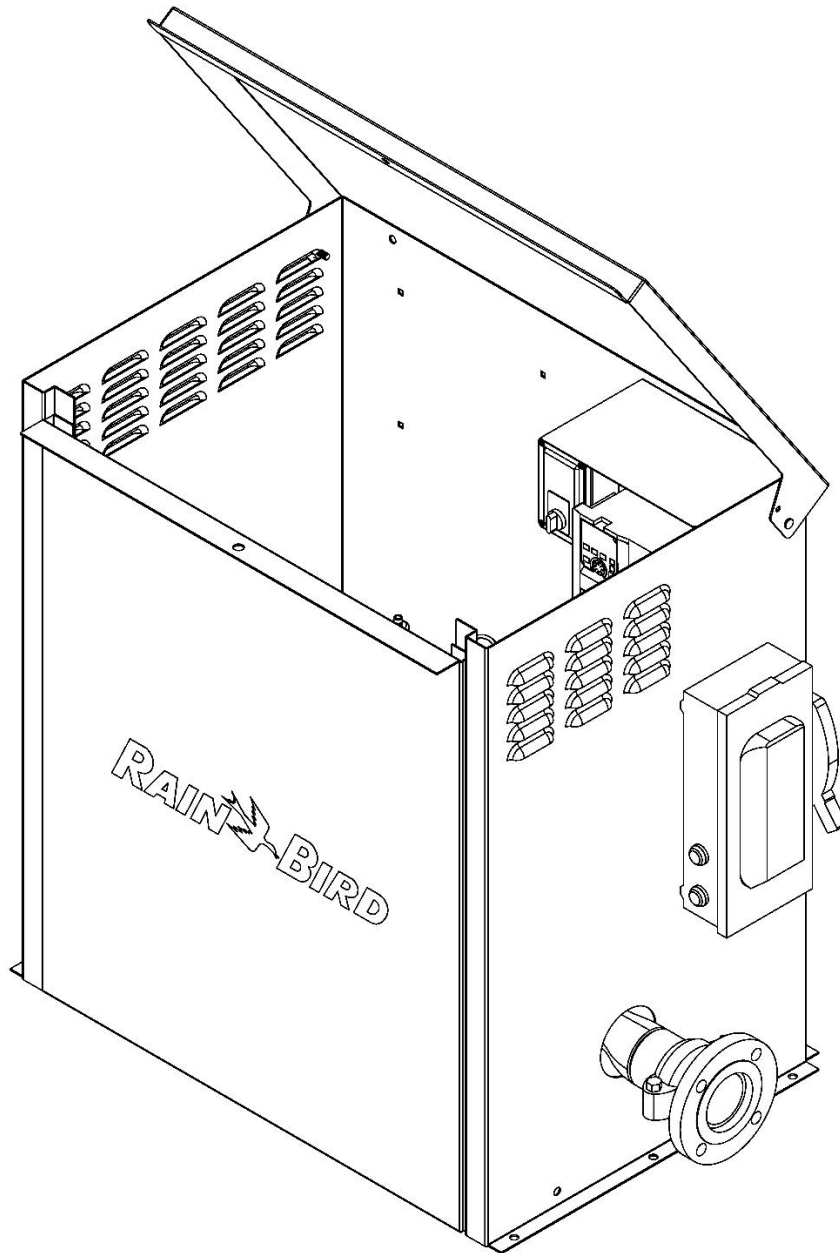

TABLE OF CONTENTS

1 Introduction	3
2 Safety Information	4
3 Receiving Instructions	7
4 Component Locations	8
5 Mechanical Installation.....	9
6 Electrical Installation	12
7 Connecting An External Input.....	16
8 Priming The Pump – Suction Lift Applications.....	19
9 How The System Works.....	21
10 Operator Interface	23
11 Setting Variable Frequency Drive Parameters	26
12 Initial Start -Up Guide.....	27
13 System Alarms And Faults	39
14 Troubleshooting	44
15 Maintenance	49
Appendix A – Pump Intake Applications.....	52
Appendix B – Suction Line And Foot Valve Guide	53
Appendix C – Power Grounding Systems	54

1 INTRODUCTION

About This Manual

Take time to read and understand this manual thoroughly.

Keep this manual and all other related documents with the pump station. Add or replace any documents provided by Rain Bird.

This manual provides the necessary installation, startup, operation and maintenance instructions for the products and models stated in Products Covered By This Manual below.

The information found in this manual is in effect at the time of printing. Rain Bird may change contents without notice and without incurring obligation.

The images throughout this manual are representative and may differ from your model.

Any reference in this manual to left or right shall be determined by looking at the pump station from the where the pump station hood can be raised.

If uncertain about any of the information in this manual, contact Rain Bird Global Service Plan (GSP) support at:

1-866-477-9778 (GSP Support)

or contact Rain Bird at:

PumpSupport@RainBird.com

Products Covered By This Manual

The following products are covered by this manual:

Compact Low Profile Rapid Ship (CLPRS) Pump Station

This includes the following models:

3HP Models

- CLP03AAC4RS
- CLP03AAC5RS
- CLP03AAC8RS
- CLP03CAC4RS

- CLP03CAC5RS
- CLP03CAC8RS

5HP Models

- CLP05EAC4RS
- CLP05EAC5RS
- CLP05EAC8RS
- CLP05FAC4RS
- CLP05FAC5RS
- CLP05FAC8RS

7.5HP Models

- CLP07HAC4RS
- CLP07HAC5RS
- CLP07JAC4RS
- CLP07JAC5RS

10HP Models

- CLP10LAC4RS
- CLP10LAC5RS



2 SAFETY INFORMATION

Intended Use Of The Pump Station

The Rain Bird Compact Low Profile Rapid Ship (CLPRS) pump station is intended for use as a stationary water pumping device for general irrigation.

Safety Definitions

For your safety, the safety of others and to protect the performance of equipment, follow the precautions listed throughout the manual before and during installation, startup, operation and periodic maintenance.



Indicates a potential personal injury hazard.



Indicates a hazardous situation which, if not avoided, **will** result in death or serious injury.



Indicates a hazardous situation which, if not avoided, **could** result in death or serious injury.



Indicates a hazardous situation which, if not avoided, **could** result in minor or moderate injury.



Information considered important but not hazard related.

Safety Precautions

The following contains general safety precautions and guidelines that must be obeyed to reduce risk to personal safety. Special safety precautions are listed in the specific procedures. Read and follow all the safety precautions before installing, operating or performing repairs or maintenance.



Electrocution Hazard

- Always disconnect the power source from the pump station before performing any work on or near the pump motor or its connected load.
- Always use proper Lockout / Tagout practices and procedures to safeguard workers.
- Always obey the rules and instructions for your work site, follow the National Electric Code (NEC), the National Fire Protection Association (NFPA) code and all local, state and province electrical and safety codes when installing the pump station.
- Do not operate the pump station if the insulation on the electrical cable or other electrical wiring is cut, worn or if bare wires are exposed.



Unsafe Operation Hazard

- Never permit anyone to install, operate, repair or maintain the pump station without proper training.
- Read and follow the instructions in this manual, and any component manuals before installing, starting, operating or maintaining the pump station.



Exposure Hazard

- Always wear personal protective equipment, including appropriate clothing, gloves, work shoes and eye protection as required for the task at hand.



Modification Hazard

- Never remove, modify or defeat safeguards on the pump station.
- Never modify the pump station without the written consent of Rain Bird.





2 SAFETY INFORMATION

Entanglement / Sever Hazard

- If the pump motor or other rotating parts must be inspected or serviced while operating, remove all jewelry, tie back long hair and keep hands, other body parts and clothing away from moving / rotating parts.
- Verify that all guards, and covers are attached properly to the equipment before starting the pump motor. Do not start the pump motor if any guard or cover is not properly installed.



California Proposition 65 Warning

- This product can expose you to chemicals known to the State of California to cause cancer and birth defects or other reproductive harm.





NOTICE

- Any part which is found defective as a result of inspection, or any part whose measured value does not satisfy the standard or limit **MUST** be replaced.
- The use of authorized replacement Rain Bird parts is recommended. The Rain Bird Customer Satisfaction Policy does not cover damage or performance problems caused by the use of parts that are not authorized replacement parts.
- Always tighten components to the specified torque. Loose parts can cause equipment damage or cause improper operation.
- Retrieve any tools or parts that may have dropped inside the pump station to avoid improper equipment operation.
- If the red Pump Station Alarm Light illuminates during pump station operation, stop the pump station immediately. Determine the cause, and repair the problem before continuing to operate the pump station.

pump station, understand and obey all hazard warnings.

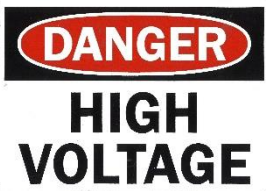
Keep the safety decals from becoming dirty or damaged, and replace them if they are lost or damaged. Replacement safety decals can be ordered from your dealer, or Rain Bird Global Service Plan (GSP) support. See **1 Introduction** for contact information.

If a part needs to be replaced that has a safety decal attached to it, make sure you order the safety decal and the new part at the same time. Make sure to install the safety decal on the new part.

<p>DANGER – High Voltage.</p>	
<p>WARNING – To prevent injury, hood must be secured prior to entry or maintenance. Secure hood using spring loaded twist release locking pins on both sides of enclosure at hinge points.</p>	
<p>WARNING – No welding on pump station.</p>	
<p>WARNING – Freeze warning. Pressure transducer must be winterized.</p>	

Safety Decals

Before installing, starting, operating or maintaining the pump station, read and follow the instructions of the following safety decals. The hazard warnings and instructions are for your safety. To avoid personal injury and / or damage to the



2 SAFETY INFORMATION

WARNING – Manual mode is for system testing only. Watering in manual mode can cause serious equipment damage or failure which is not covered by manufacturer's warranty.

 **WARNING**

MANUAL MODE IS FOR SYSTEM TESTING ONLY

Watering in manual mode can cause serious equipment damage or failure which is not covered by the Manufacturer's Warranty

WARNING – Do not operate station without first checking that system is filled with water.

WARNING

DO NOT OPERATE STATION WITHOUT FIRST CHECKING THAT SYSTEM IS FILLED WITH WATER.

Job Information Label

Model Number: _____

Job Number: _____

Performance GPM: _____ PSI: _____

Voltage: _____ Phase: _____ Hertz: _____

Total FLA: _____

Voltage: _____ Phase: _____ Hertz: _____

Total FLA: _____

*Short Circuit Current: 10KA RMS Symmetrical, V Maximum **Type 1*

Use only copper wire 60°C insulation if rated less than 100A, 75°C if rated 100A or more.

Caution: To reduce the risk of fire. Replace with only the same type of rating and fuse

Service Information



For equipment Service or Start-up,
Please call 1-866-477-9778

Para servicio de equipos o de puesta en marcha,
por favor llame 1-866-477-9778

Pour le service d'équipement ou de démarrage,
appelez-vous s'il vous plait 1-866-477-9778

Service Information

**For Rain Bird®
Pump Station
Service call
1-866-477-9778
GSP-XPRT**

3 RECEIVING INSTRUCTIONS

General

Before beginning installation of the pump station, make sure all parts, manuals and instructions are present. If any part is missing or damaged, do not attempt to install or operate the pump station.

1. Check the sales order against the Packing Slip or Bill of Lading. Make sure that all items ordered are with the pump station.
2. Examine the pump station and any optional equipment carefully to check for damaged items.
3. Record any damaged or missing items on the Bill of Lading.
4. Contact Rain Bird Global Service Plan (GSP) support regarding any damaged or missing items. See **1 Introduction** for contact information.

Items Generally Included With The Pump Station

This is a list of items that will generally come with the pump station. Check your sales order for the actual list of the standard and optional items ordered.

The items with the pump station may include but are not limited to the following:

- The pump station
- Pump station User Manual Binder containing the following:
 - Pump Station Operator Training Checklist
 - Electrical Schematic
 - Installation and Operations Manual
 - Variable Frequency Drive (VFD) Manual
 - Pump / Motor Manual
 - Flow Switch Manual

The pump station is shipped on a single pallet with the User Manual Binder wrapped in cardboard and shipped loose inside the pump station enclosure. Additionally, if optional intake and discharge adapters with couplings are ordered, these are boxed and shipped loose inside the pump station enclosure. Other optional equipment may be shipped on separate pallets.

4 COMPONENT LOCATIONS

Pump Station Layout

Identify the location of components and controls of the pump station by comparing Table 4-1 with Figures 4-1 and 4-2.

Ref	Description
A	Flanged Discharge Connection
B	Priming Port
C	Discharge Ball Valve
D	Auto-Off-Manual (AOM) Switch Box (contains Pump Start Relay)
E	Auto-Off-Manual (AOM) Switch
F	Discharge Pressure Gauge
G	Operator Interface
H	Variable Frequency Drive (VFD)
I	Flanged Intake Connection
J	Motor Junction Box
K	Centrifugal Pump
L	Pump Station Run Light (Green)
M	Pump Station Alarm Light (Red)
N	Fused Electrical Disconnect
P	Flow Switch
Q	Intake Pressure Gauge
R	Pressure Transducer

Table 4-1.

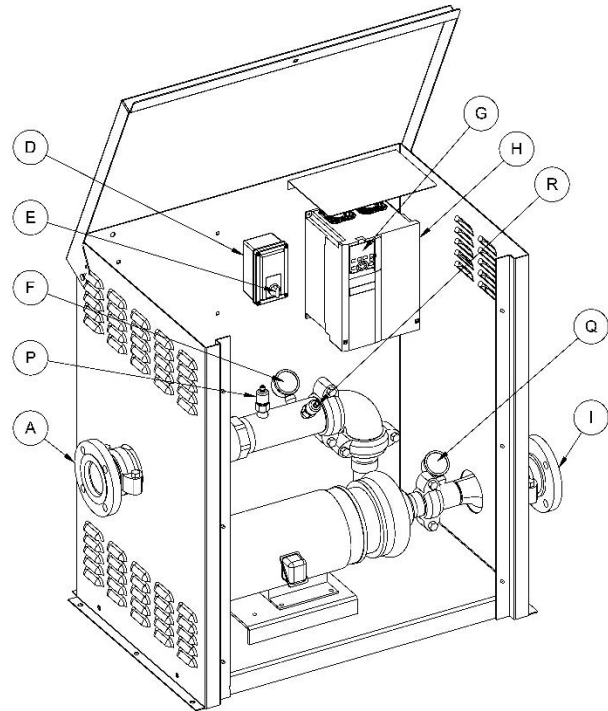

Figure 4-1. Pump Station Components.

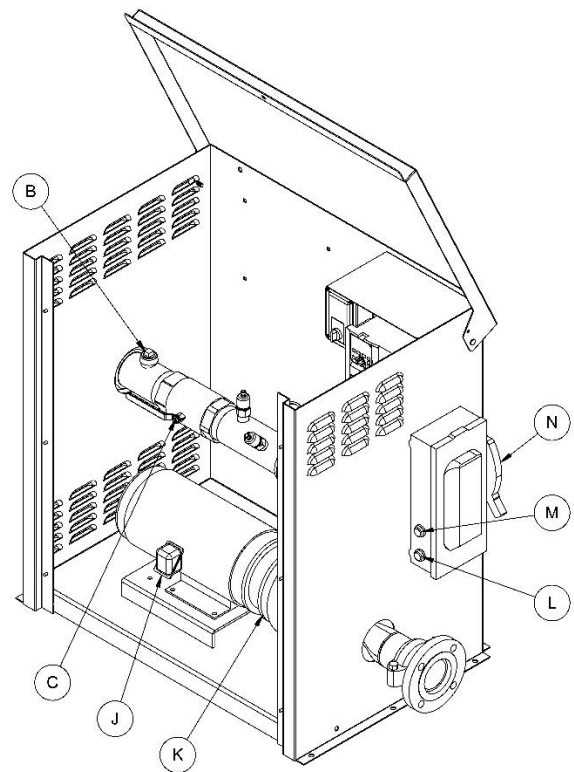

Figure 4-2. Pump Station Components.

5 MECHANICAL INSTALLATION

General

The architect or project engineer should be consulted for all construction details.

A licensed contractor must be used for site preparation and laying the concrete slab for the pump station. Follow all local, state, province and national construction codes.

A licensed plumber must be used for all water pipe connections. Follow all local, state, province and national plumbing codes, and water usage codes.

Should you have any questions regarding the mechanical installation for this pump station, contact Rain Bird Global Service Plan (GSP) support. See **1 Introduction** for contact information. Note the CLPRS Model and the Job Number found on the Job Information Label inside the pump station enclosure on the left side (see Figure 6-3), and have this information ready when calling for support.

Pump Station Location Considerations

The water source will be the prime consideration when selecting a location for the pump station. See **Appendix A – Pump Intake Applications** for description of various water supply applications.

When selecting a location for the pump station, make sure there is adequate space for accessing the hood, front cover and the internal components of the pump station for maintenance and repairs. Make sure to allow space for adequate pump station ventilation.

Make sure there is adequate space surrounding the Fused Electrical Disconnect (P, Figure 4-2) in accordance with national and local electrical codes. Ensure that the Pump Station Run Light (M, Figure 4-2) and Pump Station Alarm Light (N, Figure 4-2) are clearly visible.

Rain Bird recommends installing the pump station in an area that does not receive direct sunlight. This will reduce the temperature fluctuations inside the pump station enclosure, and maximize component life.

Installation Instructions

Before beginning installation of the pump station, read and follow all instructions in **2 Safety Information** section of this manual.

Read and understand all installation instructions, hazard warnings and relevant appendices before beginning the installation.



Attempting mechanical installation of the pump station when it is connected to an electrical power source will result in death or serious injury. Always make sure the pump station is disconnected from any electrical power source before beginning mechanical installation.

1. The pump station must be anchored to a concrete slab. The concrete slab must be a minimum of 6 inches (150 mm) larger than the pump station base on all sides. The footprint of the pump station base is 38" (965 mm) x 26" (660 mm). See Figure 5-1. The concrete slab must be as flat and level as possible. Follow all local, state, province and national construction codes for sub-base, thickness and reinforcement of the concrete slab.
2. Place the pump station on the concrete slab.

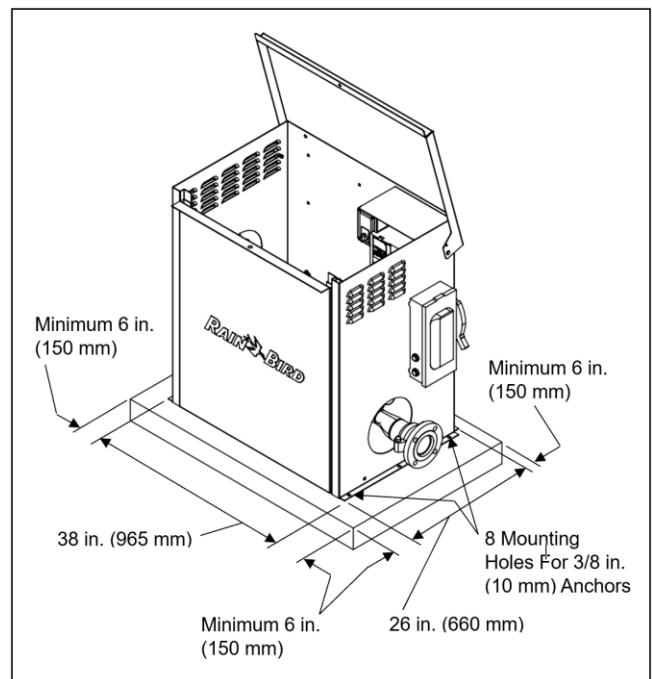

Figure 5-1. Location Of Pump Station On Slab.

5 MECHANICAL INSTALLATION

NOTICE

Operating the pump station with the pump motor base not level could result in reduced life of the pump. Always make sure the pump motor base is level when the pump station is anchored to the concrete slab.

WARNING

Leaving the hood in the raised position without engaging the retractable spring plunger pin could allow the hood to come down on top of anyone working under it, which could result in death or serious injury. Always engage the retractable spring plunger pin in the hole adjacent to the hinge pin.

3. To gain access to the pump motor base for leveling the pump station:
 - a. Raise the pump station hood. Ensure that the retractable spring plunger pin on the left side of the enclosure near the hinge pin is engaged in the hole adjacent to the hinge pin on the cover. See Figure 5-2.

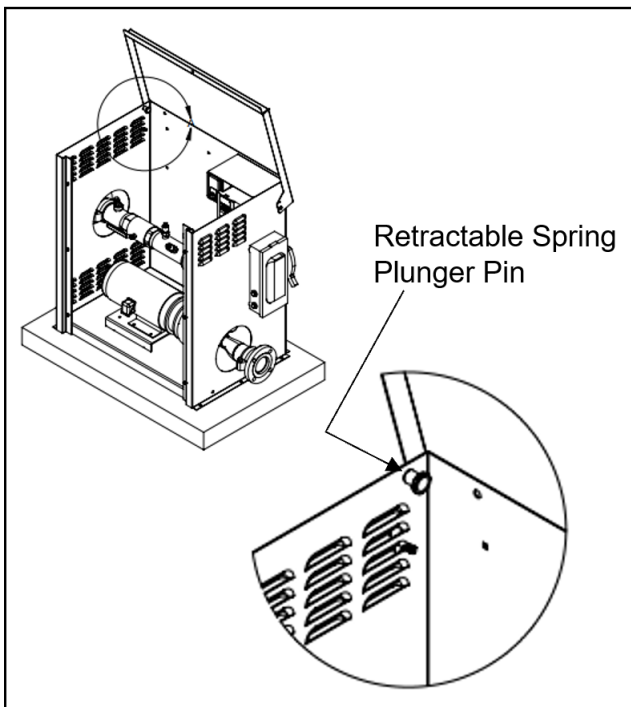

Figure 5-2. Engaging The Retractable Spring Plunger Pin.

- b. Remove the front cover panel by removing the six screws located on the inside of the

pump station enclosure and lifting the front cover away from the flanges on either side of the enclosure. See Figure 5-3.

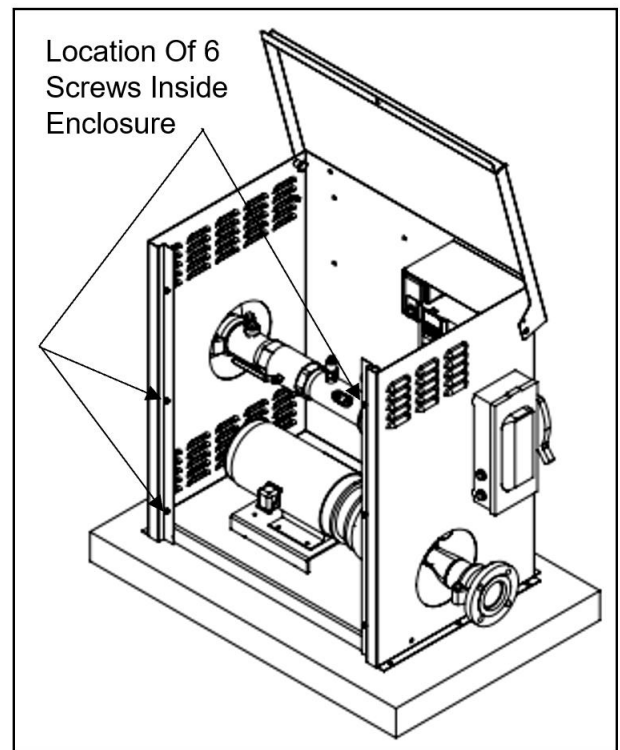

Figure 5-3. Removing The Front Cover.

4. Check that the pump motor base is level. Use steel shims at each mounting hole to bring the pump motor base level.
 5. Anchor the pump station to the concrete slab using the 8 mounting holes provided at the base of the pump station. Rain Bird recommends using 3/8" x 2-3/4" stainless steel wedge type anchors. Follow all local, state, province and national construction codes when selecting anchors.

NOTICE

Operating the pump station in Suction Lift applications without a foot valve can result in serious damage to the pump. Always install a foot valve to maintain prime in the pump when installing the pump station in Suction Lift applications.

6. If the pump station is to be used in a Suction Lift application (see **Appendix A- Pump Intake Applications**), install a foot valve as low as possible on the suction line in the water

5 MECHANICAL INSTALLATION

source. See **Appendix B – Suction Line And Foot Valve Guide** for guidance on selection and installation of foot valves. The flapper of the foot valve must be closed when the pump is not operating.

7. Connect the line from the water source to the Flanged Intake Connection (J, Figure 4-1). Follow the manufacturers recommendations for connection and assembly of Victaulic pipe connections.
8. Connect the Flanged Discharge Connection (A, Figure 4-1) to the irrigation field. Follow the manufacturers recommendations for connection and assembly of Victaulic pipe connections.
9. Inspect all pipe connections for leaks. Pay particular attention to the suction line in Suction Lift applications. Correct any leak that is found.
10. When finished working inside the pump station enclosure:
 - a. Re-install the front cover by placing the cover in the flanges on either side of the pump station enclosure. Secure the front cover by re-installing the six screws in the holes located inside the pump station enclosure. See Figure 5-3.

side of the enclosure near the hinge pin with the other. Disengage the plunger pin from the hole adjacent to the hinge pin before lowering the hood. See Figure 5-2.

NOTICE

Attempting to close the pump station hood without first disengaging the retractable spring plunger pin from the hole adjacent to the hinge pin will result in damage to the retractable spring plunger pin or hinge area. Always pull the knob of the retractable spring plunger and ensure that the plunger pin has disengaged from the hole adjacent to the hinge pin before closing the hood.

WARNING

Disengaging the retractable spring plunger pin from the hole adjacent to the hinge pin without having a firm grip on the pump station hood could result in death or serious injury. Always have a firm grip on the pump station hood before disengaging the retractable spring plunger pin from the hole adjacent to the hinge pin.

- b. Have a firm grip on the pump station hood with one hand, while pulling the knob of the retractable spring plunger on the left

6 ELECTRICAL INSTALLATION

General

The project engineer should be consulted for all electrical details.

All electrical connections must be made by a licensed electrician.

Always follow the National Electric Code (NEC), the National Fire Protection Association (NFPA) code and all local, state and province electrical and safety codes when installing the pump station.

Should you have any questions regarding the electrical installation for this pump station, contact Rain Bird Global Service Plan (GSP) support. See **1 Introduction** for contact information. Note the CLPRS Model and the Job Number found on the Job Information Label inside the pump station enclosure on the left side (see Figure 6-3), and have this information ready when calling for support.

Installation Instructions

Before beginning installation of the pump station, read and follow all instructions in **2 Safety Information** section of this manual.

Read and understand all installation instructions, hazard warnings and relevant appendices before beginning the installation.



Working with electrically energized leads will result in death or serious injury. Always make sure the service breaker or disconnect ahead of the pump station is OPEN, and that proper Lockout / Tagout procedures are followed before beginning electrical installation.

1. Verify that the service breaker or disconnect ahead of the pump station is OPEN. Use proper Lockout / Tagout procedures.
2. Verify that the Fused Electrical Disconnect (P, Figure 4-2) on the pump station is OFF. The handle must be in the down position. Use proper Lockout/Tagout procedures. See Figure 6-1.

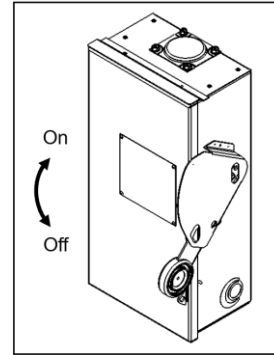

Figure 6-1. Fused Electrical Disconnect In OFF Position.



Leaving the hood in the raised position without engaging the retractable spring plunger pin could allow the hood to come down on top of anyone working under it, which could result in death or serious injury. Always engage the retractable spring plunger pin in the hole adjacent to the hinge pin.

3. To gain access to the internal electrical equipment of the pump station:
 - a. Raise the pump station hood. Ensure that the retractable spring plunger pin on the left side of the enclosure near the hinge pin is engaged in the hole adjacent to the hinge pin on the cover. See Figure 5-2.
 - b. If it is necessary to remove the front cover, remove the six screws located on the inside of the pump station enclosure and lift the front cover away from the flanges on either side of the enclosure. See Figure 5-3.
4. Set the Auto-Off-Manual (AOM) Switch (E, Figure 4-1) in the OFF position. See Figure 6-2.

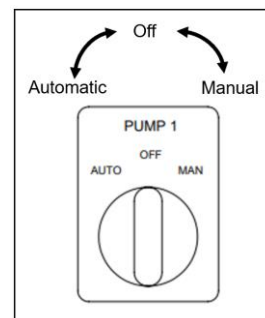

Figure 6-2. Auto-Off-Manual Switch.

6 ELECTRICAL INSTALLATION



The presence of moisture in high voltage electrical enclosures when electrically energized will result in death or serious injury. Always check for the presence of moisture in high voltage electrical enclosures before connecting power cables, and replace the enclosure if moisture is found to be entering it.

5. Open the door of the Fused Electrical Disconnect. Verify that no moisture is present in the Fused Electrical Disconnect enclosure. If moisture is present, do not proceed. Contact Rain Bird Global Service Plan (GSP) support. See **1 Introduction** for contact information.
6. Electrical information for the pump station can be found on the Job Information Label inside the pump station enclosure on the left side. See Figure 6-3.

Model Number: _____	
Job Number: _____	
Performance GPM: _____	PSI: _____
Voltage: _____	Phase: _____ Hertz: _____
Total FLA: _____	
Voltage: _____	Phase: _____ Hertz: _____
Total FLA: _____	
<small>*Short Circuit Current: 10kA RMS Symmetrical, V Maximum * *Type 1* Use only copper wire 60°C insulation if rated less than 100A, 75°C if rated 100A or more. Caution: To reduce the risk of fire Replace with only the same type of rating and fuse</small>	

Figure 6-3. Job Information Label.

7. Verify that the electrical power at the service breaker or disconnect ahead of the power station is the correct phase and voltage for the pump station. Record this information in Table 6-1. This information will be required when performing the Initial Start-Up.

Voltage	
No. Of Phases	

Table 6-1. Electrical Information.



Undersized wiring can overheat and cause a fire resulting in death or serious injury. Always size electrical wiring per codes for the full load amps required by the pump station.

8. Make sure the power leads from the service breaker or disconnect ahead of the power station to the Fused Electrical Disconnect are properly sized for the Full Load Amps (FLA) as stated on the Job Information Label (see Figure 6-3).
9. Connect the power leads to the appropriate terminals in the Fused Electrical Disconnect.
 - a. For single phase, connect power leads to terminals L1 and L2.
 - b. For 3 phase, connect power leads to terminals L1, L2 and L3.



The Delta Variable Frequency Drive (VFD) contains a Radio Frequency Interference (RFI) jumper that, when installed on a symmetric (wye or "Y") 3-phase system, will protect the drive from transient voltage spikes and main line surges, as well as high frequency noise. When installing the pump station on asymmetric grounded systems (3-phase delta or Δ, 3-phase autotransformer or single phase), leaving the RFI jumper in place could result in grounding through the VFD filter capacitors causing damage to the VFD. Always remove the RFI jumper on asymmetric grounded systems, including single phase systems, to prevent damage to the VFD.



Working on the VFD with the cover removed when the VFD is connected to an electrical power source will result in death or serious injury. Always make sure the pump station is disconnected from any electrical power source before removing the cover of the VFD.

10. Determine if your power system is a symmetric or asymmetric grounding power system. See **Appendix C – Power Grounding Systems**.
11. If your system is a symmetric grounding power system, proceed to Step 13.

6 ELECTRICAL INSTALLATION

12. If your system is an asymmetric grounding power system the Radio Frequency Interference (RFI) jumper will need to be removed.
 - a. Remove the cover from the VFD module (H, Figure 4-1).
 - b. Loosen the screw shown in Figure 6-4.

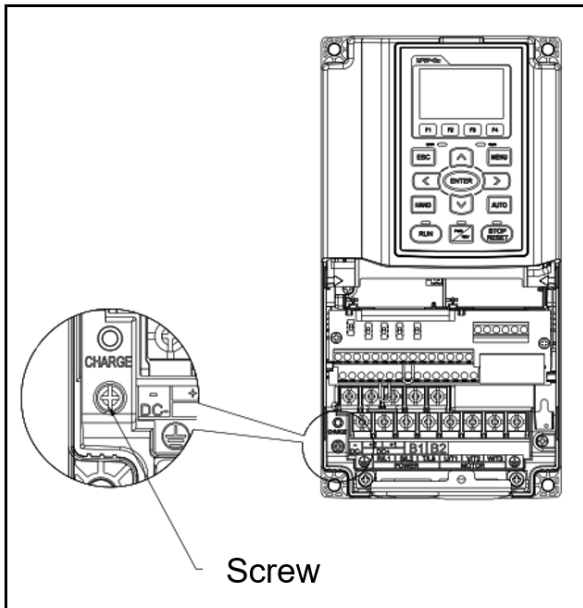

Figure 6-4. RFI Jumper Screw.

- c. Remove the MOV-PLATE shown in Figure 6-5.
 - d. Tighten screw to 6.9 – 8.7 lb-in (0.8 – 1.0 Nm).
 - e. Re-install cover on VFD module.

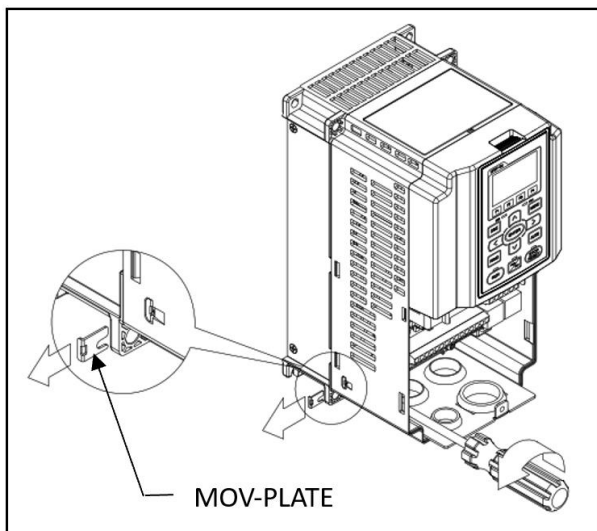

Figure 6-5. Removing MOV-PLATE.

NOTICE

Sharing the earth ground of the pump station with other equipment could result in interference with the operation of the Variable Frequency Drive. Always use a separate earth ground for the pump station.

13. Use the pump station ground terminal in the Fused Electrical Disconnect enclosure to connect the pump station to an earth ground. Use an earth ground that is separate from other equipment.
14. Verify that all screw terminals are tight, and that all wires are secure. Inspect connections to make sure there are no exposed wires.
15. Close the door of the Fused Electrical Disconnect.
16. When finished working inside the pump station enclosure:
 - a. Re-install the front cover by placing the cover in the flanges on either side of the pump station enclosure. Secure the front cover by re-installing the six screws in the holes located inside the pump station enclosure. See Figure 5-3.

NOTICE

Attempting to close the pump station hood without first disengaging the retractable spring plunger pin from the hole adjacent to the hinge pin will result in damage to the retractable spring plunger pin or hinge area. Always pull the knob of the retractable spring plunger and ensure that the plunger pin has disengaged from the hole adjacent to the hinge pin before closing the hood.

WARNING

Disengaging the retractable spring plunger pin from the hole adjacent to the hinge pin without having a firm grip on the pump station hood could result in death or serious injury. Always have a firm grip on the pump station hood before disengaging the retractable spring plunger pin from the hole adjacent to the hinge pin.

- b. Have a firm grip on the pump station hood with one hand, while pulling the knob of the retractable spring plunger on the left side of the enclosure near the hinge pin

6 ELECTRICAL INSTALLATION

with the other. Disengage the plunger pin from the hole adjacent to the hinge pin before lowering the hood. See Figure 5-2.

17. If the pump station is to be used with an external input from an irrigation controller (Clock Start), proceed to **7 Connecting An External Input** section.

NOTICE

When using the pump station in Suction Lift applications, operating the pump without performing the proper priming procedure could result in damage to the pump. Always perform the proper priming procedure before starting the pump.

18. If the pump station is to use a Time Of Day Start **AND** is used in a Suction Lift application, the pump must be primed before the pump is operated. Proceed to **8 Priming The Pump** section and perform the priming procedure.
19. If the pump station is to use a Flow Start or Time Of Day Start **AND** is used in a Pressure Boost application or a Flooded Suction application, proceed to **9 How The System Works** section.

7 CONNECTING AN EXTERNAL INPUT

General

The Compact Low Profile Rapid Ship (CLPRS) pump station requires a signal to start the pump. When the Variable Frequency Drive (VFD) receives the appropriate start signal and the pump station Auto-Off-Manual (AOM) Switch is in the AUTO position, it will start the pump and bring the system to the configured pump pressure Set Point. The start signal can be provided from an irrigation controller when it is connected to the included Pump Start Relay, or from the included Flow Switch depending on the intake application.

Pump stations that are used in Pressure Boost applications (see **Appendix A – Pump Intake Applications**) may use input from the Flow Switch (Flow Start), or an external irrigation controller (Clock Start) to signal the VFD to wake the pump station (see Wake / Start Configuration in **12 Initial Start-Up Guide** section).

Pump stations that are used in Flooded Suction applications (see **Appendix A – Pump Intake Applications**) can use the Flow Switch (Flow Start) only if the dynamic inlet pressure is high enough to produce adequate flow when irrigation demand is present. Most Flooded Suction applications will be configured with external input from an irrigation controller (Clock Start) via the Pump Start Relay as there is generally not a significant elevation change from the water supply to the pump inlet.

Pump stations that are used in Suction Lift applications (see **Appendix A – Pump Intake Applications**) may use an external input from an irrigation controller (Clock Start) to signal the VFD to wake the pump station (see Wake / Start Configuration in **12 Initial Start-Up Guide** section). Flow Start is not suitable for Suction Lift systems.

The pump station may be ordered with a 24 VAC / VDC Pump Start Relay, or an Integrated Valve Module Output Module (IVM-OUT).

The project engineer should be consulted for all electrical details.

All electrical connections must be made by a licensed electrician.

Always follow the National Electric Code (NEC), the National Fire Protection Association (NFPA) code and all local, state and province electrical and safety codes when installing an irrigation controller.

Should you have any questions regarding connecting an external input to this pump station, contact Rain Bird Global Service Plan (GSP) support. See **1 Introduction** for contact information. Note the CLPRS Model and the Job Number found on the Job Information Label inside the pump station enclosure on the left side (see Figure 6-3), and have this information ready when calling for support.

Flow Switch

The pump station is provided with Flow Switch (Q, Figure 4-2) already installed. If the pump station is to be used in a Pressure Boost application (see **Appendix A – Pump Intake Applications**), Flow Start may be used without connecting any further external input.

Connecting An Irrigation Controller

Two types of irrigation controllers can be connected to the pump station: traditionally wired irrigation controllers and decoder irrigation controllers.

Traditional 24 VAC irrigation controllers such as the Rain Bird ESP-LXME, use separate wires to each irrigation valve.

Decoder type irrigation controllers such as the Rain Bird ESP-LXD, use a single pair of wires to control multiple irrigation valves by using a signal specific to each irrigation valve decoder to turn the valve on or off. A decoder capable of energizing the Pump Start Relay, such as the Rain Bird FD-102, will be required.

Before beginning installation of the irrigation controller, read and follow all instructions in **2 Safety Information** section of this manual.

Read and understand all installation instructions, hazard warnings and relevant appendices before beginning the installation.

7 CONNECTING AN EXTERNAL INPUT

NOTICE

Failure to complete the Mechanical and Electrical installations prior to installing an irrigation controller could result in equipment damage. Always complete the Mechanical and Electrical installations before installing an irrigation controller.

To install the irrigation controller system:

WARNING

Leaving the hood in the raised position without engaging the retractable spring plunger pin could allow the hood to come down on top of anyone working under it, which could result in death or serious injury. Always engage the retractable spring plunger pin in the hole adjacent to the hinge pin.

1. To gain access to the internal electrical equipment of the pump station:
 - a. Raise the pump station hood. Ensure that the retractable spring plunger pin on the left side of the enclosure near the hinge pin is engaged in the hole adjacent to the hinge pin on the cover. See Figure 5-2.
 - b. If it is necessary to remove the front cover, remove the six screws located on the inside of the pump station enclosure and lift the front cover away from the flanges on either side of the enclosure. See Figure 5-3.
2. Verify that the Auto-Off-Manual (AOM) Switch (E, Figure 4-1) is in the OFF position. See Figure 6-2.

DANGER

Working with electrically energized components in the pump station enclosure will result in death or serious injury. Always make sure the Fused Electrical Disconnect on the pump station is OFF, and that proper Lockout / Tagout procedures are followed before beginning installation of an irrigation controller.

3. Verify that the Fused Electrical Disconnect (P, Figure 4-2) on the pump station is OFF. The handle must be in the down position. See Figure 6-1.

4. The irrigation controller can be mounting inside the pump station enclosure, or at another location.
 - a. Rain Bird can provide a bracket for mounting Rain Bird irrigation controllers inside the pump station enclosure.
 - b. When the irrigation controller is not mounted inside the pump station enclosure, run Maxi wires from the irrigation controller to the inside of the pump station enclosure.
5. Open the cover on the AOM Switch Box (D, Figure 4-1).
6. Run the black and red Maxi wires from the irrigation controller into the AOM Switch Box.
7. For traditional irrigation controllers such as the Rain Bird ESP-LXME, connect the Maxi wires from the irrigation controller to the Pump Relay block. The connections are not polarity sensitive:
 - a. Connect the black wire to either terminal A1 or A2.
 - b. Connect the red wire to remaining terminal.
8. For decoder type irrigation controllers such as the Rain Bird ESP-LXD with the Rain Bird FD-102 Decoder:
 - a. Connect the black and red Maxi wires from the irrigation controller to the two blue wires of the decoder using waterproof wire nuts.
 - b. Connect one white decoder wire to terminals A1 and the other to terminal A2 on the Pump Start Relay block. The connections are not polarity sensitive.
9. An Integrated Valve Module Output Module (IVM-OUT) is required when using Rain Bird IVM controllers. When ordered, Rain Bird supplies the DC latching relay shipped loose with the pump station. The DC latching relay plugs into the relay base. Output wires of the IVM-OUT must be connected to terminals A and B of the DC latching relay base. See IVM Manual for complete installation instructions.
10. Verify that all screw terminals are tight, and that no bare wires are exposed.
11. Close the cover on the AOM Switch Box.
12. Apply electrical power to the pump station by setting the Fused Electrical Disconnect on the pump station to ON. The handle must be in the up position. See Figure 7-4.

7 CONNECTING AN EXTERNAL INPUT

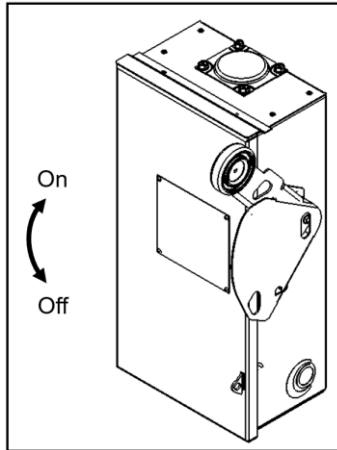

Figure 7-4. Fused Electrical Disconnect In ON Position.

13. Consult the irrigation controller User Manual to program the irrigation controller. This may vary by controller, but typically, it will need to be programmed to operate the pump station with a Normally Open Contact (NO) pump start signal.
 14. When finished working inside the pump station enclosure:
 - a. Re-install the front cover by placing the cover in the flanges on either side of the pump station enclosure. Secure the front cover by re-installing the six screws in the holes located inside the pump station enclosure. See Figure 5-3.
 - b. Have a firm grip on the pump station hood with one hand, while pulling the knob of the retractable spring plunger on the left side of the enclosure near the hinge pin with the other. Disengage the plunger pin from the hole adjacent to the hinge pin before lowering the hood. See Figure 5-2.
15. If the pump station is used in a Suction Lift Application (see **Appendix A – Pump Intake Applications**), proceed to **8 Priming The Pump – Suction Lift Applications** section and perform the priming procedure.
 16. If the pump station is used in Pressure Boost or Flooded Suction applications (see **Appendix A – Pump Intake Applications**), proceed to **9 How The System Works** section.

NOTICE

Attempting to close the pump station hood without first disengaging the retractable spring plunger pin from the hole adjacent to the hinge pin will result in damage to the retractable spring plunger pin or hinge area. Always pull the knob of the retractable spring plunger and ensure that the plunger pin has disengaged from the hole adjacent to the hinge pin before closing the hood.

WARNING

Disengaging the retractable spring plunger pin from the hole adjacent to the hinge pin without having a firm grip on the pump station hood could result in death or serious injury. Always have a firm grip on the pump station hood before disengaging the retractable spring plunger pin from the hole adjacent to the hinge pin.

8 PRIMING THE PUMP – SUCTION LIFT APPLICATIONS

General

When the pump station is used in Suction Lift applications (see **Appendix A – Pump Intake Applications**), the pump will need to be primed. For Pressure Boost or Flooded Suction applications, this procedure does not apply.

Should you have any questions regarding priming the pump, contact Rain Bird Global Service Plan (GSP) support. See **1 Introduction** for contact information. Note the CLPRS Model and the Job Number found on the Job Information Label inside the pump station enclosure on the left side (see Figure 6-3), and have this information ready when calling for support.

Instructions For Priming The Pump

Before beginning priming the pump, read and follow all instructions in **2 Safety Information** section of this manual.

Read and understand all instructions, hazard warnings and relevant appendices before beginning priming the pump.



Priming the pump when high voltage electricity is present in the pump station enclosure will result in death or serious injury. Always make sure the Fused Electrical Disconnect lever is in the OFF position, and that proper Lockout / Tagout procedures are followed before beginning the priming procedure.

1. Verify that the Fused Electrical Disconnect (P, Figure 4-2) on the pump station is OFF. The handle must be in the down position. Use proper Lockout/Tagout procedures. See Figure 6-1.
2. Verify that the suction line is free of leaks and is properly supported (see **Appendix B – Suction Line And Foot Valve Guide**).



Leaving the hood in the raised position without engaging the retractable spring plunger pin could allow the hood to come down on top of anyone

working under it, which could result in death or serious injury. Always engage the retractable spring plunger pin in the hole adjacent to the hinge pin.

3. To gain access to the internal equipment of the pump station:
 - a. Raise the pump station hood. Ensure that the retractable spring plunger pin on the left side of the enclosure near the hinge pin is engaged in the hole adjacent to the hinge pin on the cover. See Figure 5-2.
 - b. If it is necessary to remove the front cover, remove the six screws located on the inside of the pump station enclosure and lift the front cover away from the flanges on either side of the enclosure. See Figure 5-3.
4. Ensure that the master valve directly after the pump station discharge is closed.
5. Open the Discharge Ball Valve (C, Figure 4-1) by placing the handle controlling the valve butterfly parallel to the discharge piping. See Figure 8-1.

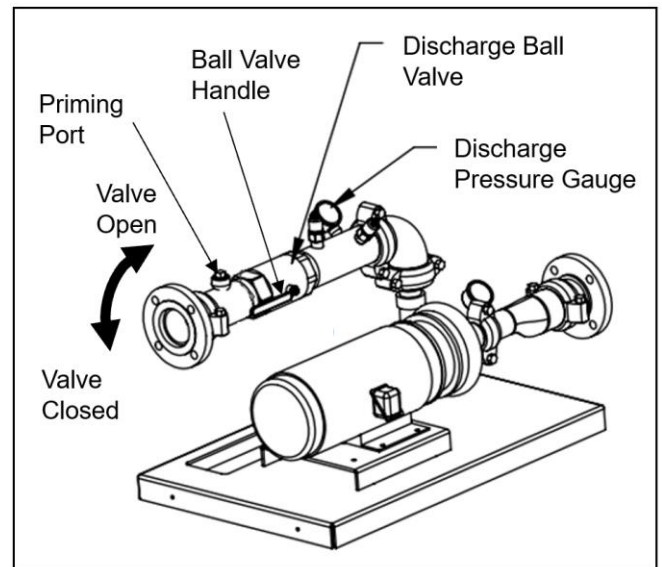

Figure 8-1. Pump Discharge System.

6. Remove the plug from the Priming Port (B, Figure 4-1) on the discharge pipe. See Figure 8-1.
7. Fill the entire suction line with water through the Priming Port. See Table 8-1 to determine the estimated volume of water required to fill your particular suction line arrangement.

8 PRIMING THE PUMP – SUCTION LIFT APPLICATIONS

Nominal Pipe Diameter	Approximate Suction Line Length											
	Ft		m		Ft		m		Ft		m	
	10	3	20	6	30	9	40	12	50	15		
In	mm	Gal	Liter	Gal	Liter	Gal	Liter	Gal	Liter	Gal	Liter	
2	50	2	8	3	11	5	19	7	26	8	30	
2 1/2	64	3	11	5	19	8	30	10	38	13	49	
3	76	4	15	7	26	11	42	15	57	18	68	
4	102	7	26	13	49	20	76	26	98	33	125	
6	152	15	58	29	110	44	167	59	223	73	276	
8	203	26	98	52	197	78	295	104	394	131	496	

Table 8-1. Priming Volume.

8. Gently tap the suction line to eliminate pockets of air in the line. All air has been vented from the suction line and station intake when water is visible in the Priming Port threaded section.
9. Mark the water level in the Priming Port with a paint pen and let the pump station set for 1/2 hour. Check the water level in the Priming Port.
10. If the water level has lowered, this indicates a leak. Verify that there is no debris present preventing the foot valve from closing. Maintain the foot valve in accordance with manufacturers guidelines to ensure it is sealing correctly. Then, repeat Steps 7, 8 and 9.
11. If the water level has not lowered, re-install the plug in the Priming Port following the standard procedure for assembling tapered pipe threads.
12. When finished working inside the pump station enclosure:
 - a. Re-install the front cover by placing the cover in the flanges on either side of the pump station enclosure. Secure the front cover by re-installing the six screws in the holes located inside the pump station enclosure. See Figure 5-3.

NOTICE

Attempting to close the pump station hood without first disengaging the retractable spring plunger pin from the hole adjacent to the hinge pin will result in damage to the retractable spring plunger pin or hinge area. Always pull the knob of the retractable spring plunger and ensure that the plunger pin has disengaged from the hole adjacent to the hinge pin before closing the hood.



Disengaging the retractable spring plunger pin from the hole adjacent to the hinge pin without having a firm grip on the pump station hood could result in death or serious injury. Always have a firm grip on the pump station hood before disengaging the retractable spring plunger pin from the hole adjacent to the hinge pin.

- b. Have a firm grip on the pump station hood with one hand, while pulling the knob of the retractable spring plunger on the left side of the enclosure near the hinge pin with the other. Disengage the plunger pin from the hole adjacent to the hinge pin before lowering the hood. See Figure 5-2.
13. Do not start the pump station at this point. Proceed to **9 How The System Works** section.

9 HOW THE SYSTEM WORKS

General

The Compact Low Profile Rapid Ship (CLPRS) pump station provides constant water pressure to an irrigation system. The system flow rate and incoming pressure may fluctuate, but the Variable Frequency Drive (VFD) adjusts the speed of the pump motor to maintain the pump pressure Set Point. The VFD analyzes feedback from a Pressure Transducer with an advanced Proportional Integral Derivative (PID) algorithm for rapid and stable operation. As the pressure rises, the motor speed slows. If the pressure decreases, then the motor speed will increase to maintain the pump pressure Set Point.

Various parameters can be set or adjusted in the VFD through the Operator Interface. The system can be monitored through the Operator Interface.

Basic System Operation

The pump station is electrically energized by switching the Fused Electrical Disconnect (P, Figure 4-2) to the ON position. CLPRS pump stations can be configured to start three ways:

- **Flow Start** – The system will wake when flow is detected.
- **Clock Start** – The system will wake when a signal is present from an irrigation controller.
- **Time Of Day Start** – The system will wake based on the time of day.

Combinations of these start options can also be used. Both of the following conditions need to be met if enabled.

- Flow Start and Clock Start
- Flow Start and Time Of Day Start
- Clock Start and Time Of Day Start

All of the following conditions must be met if enabled.

- Flow Start, Clock Start and Time Of Day Start

Flow Start and Clock Start require an external input. Time Of Day Start is internal to the pump station's VFD. The Auto-Off-Manual (AOM) switch (E, Figure 4-1) will start or stop the pump station. When the AOM switch is set to AUTO, the system will wake when a start signal is received from the external input, or upon a preset time in

the VFD (H, Figure 4-1). For Suction Lift Systems (see **Appendix A – Pump Intake Applications**), either the Clock Start or Time Of Day Start is used. For Pressure Boost or Flooded Suction Systems (see **Appendix A – Pump Intake Applications**), any of the start systems may be used.

When the AOM Switch is set to AUTO, and the pump station is receiving the appropriate start signal, the Centrifugal Pump (L, Figure 4-2) will start. If the minimum rest time for the pump has not elapsed, there will be a delay before the pump starts. The VFD will vary the speed of the pump motor to maintain the pump pressure Set Point. The green Pump Station Run Light (M, Figure 4-2) will illuminate when the VFD is running.

When the pump station is no longer receiving a start signal, the pump will shut down until the next irrigation event. If the minimum run time for the pump has not elapsed, there may be a delay between the end of the start signal and the pump turning off.

When the AOM Switch is set to MANUAL the system will start and run without a start signal. The system will attempt to maintain the pump pressure Set Point. Unlike other pump systems, the pump station will not run at full speed if the system is over the pump pressure Set Point. The minimum run and rest times apply during manual operation. Manual operation is intended for testing and troubleshooting purposes only. The pump station should not be left unattended during manual operation.

The VFD will not run when the AOM Switch is set to OFF. However, electrical power is still present on all circuits.

In the event that electrical power needs to be disconnected from the pump station, move the lever on the Fused Electrical Disconnect on the pump station to the OFF position.

Pump Station Pipe Fill Mode

The CLPRS pump station includes a Pipe Fill Mode that allows for the filling of empty irrigation pipes to reduce water hammer¹, a condition that increases the stress on irrigation piping. The Pipe Fill Mode will allow the pump station to fill the system slowly when the pump is started while the system pressure is below a configured threshold.

9 HOW THE SYSTEM WORKS

The pump station will exit the Pipe Fill Mode after the pressure threshold has been reached, or a configured time period has elapsed. The Pipe Fill Mode can be enabled or disabled.

¹ Water Hammer or hydraulic shock is a pressure surge or wave caused when fluid in motion is forced to stop or change direction suddenly.

Low Level Safety Float Switch (Optional)

The optional Low Level Safety Float Switch may be ordered for pump stations used in Suction Lift applications. This switch will trip an alarm and shut down the pump station when the source water level is below a pre-set level.

10 OPERATOR INTERFACE

General

The Operator Interface (G, Figure 4-1) is on the Variable Frequency Drive (H, Figure 4-1) module.

Figure 10-1 shows the location of components on the Operator Interface.

Figure 10-2 shows the information that is displayed in the System Status screen on the Operator Interface Monitor.

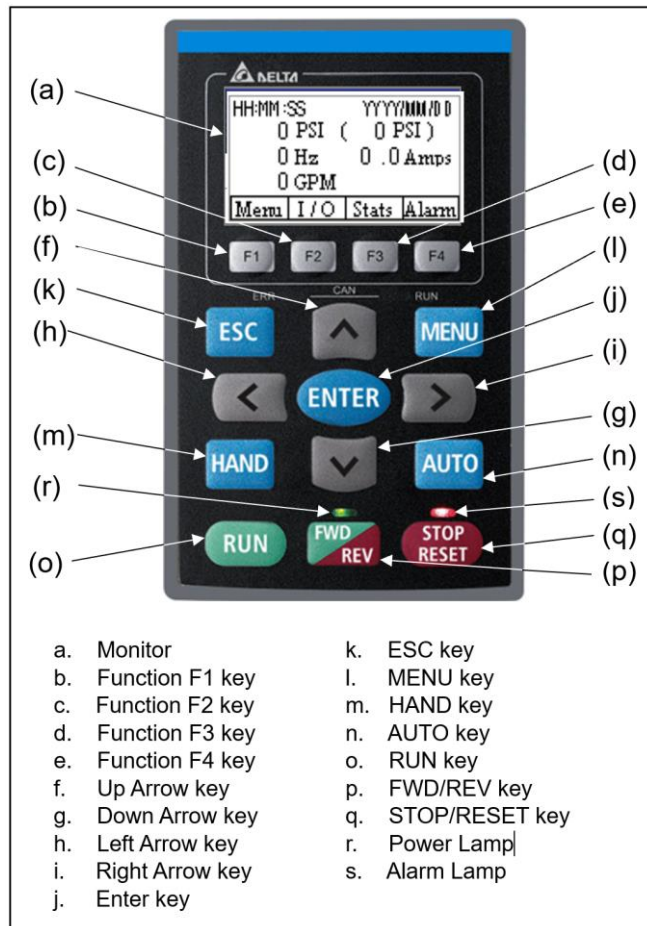

Figure 10-1. Operator Interface.

Refer to the Variable Frequency Drive (VFD) Manual for detailed information regarding the Operator Interface.

NOTICE

- Operating the Operator Interface keys with sharp tools can result in damage to the keys or keypad. Always operate the Operator Interface keys using your fingers.
- Pressing on the LCD Monitor can result in damage to the LCD. The LCD **IS NOT** a touch screen. Never press on the LCD Monitor.

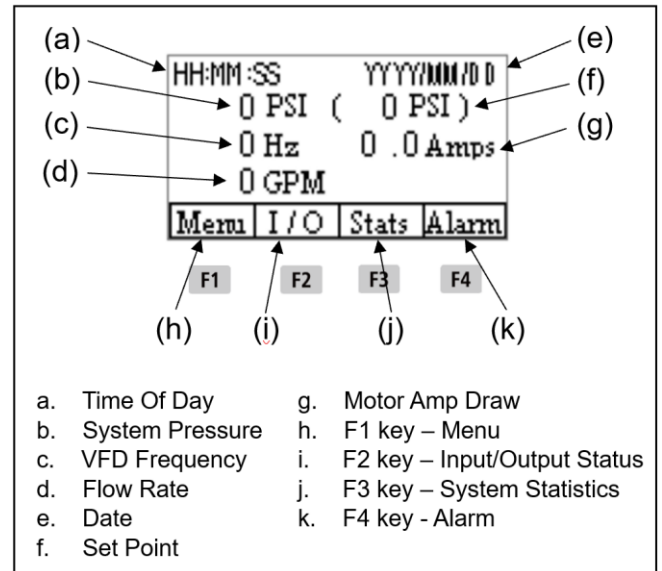

Figure 10-2. System Status Screen

User Menu And VFD Menu

There are separate menus for Rain Bird configuration and the VFD configuration. The User Menu for Rain Bird configuration is accessed by pressing the **F1** Menu key from the System

Status screen. Pressing the **MENU** key will access the VFD Menu for VFD configuration. To return to the System Status Screen from the VFD Menu, press the **ESC** key (see Figure 10-3).

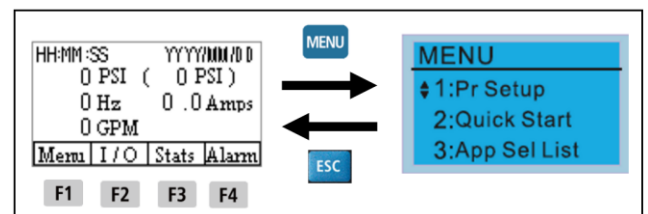

Figure 10-3. Moving Between System Status Screen And VFD Menu.

10 OPERATOR INTERFACE

If the User Menu is not accessible as described above, perform the following (see Figure 10-4):

1. Press the **MENU** key to get to the VFD Menu.
2. Use the **↑** and **↓** keys to scroll to option 13: Start-Up Menu. Press the **ENTER** key.
3. Use the **↑** and **↓** keys to scroll to “User Defined”. Press the **ENTER** key.
4. Press the **MENU** to return to the VFD Menu.
5. Use the **↑** and **↓** keys to scroll to option 14: Main Page. Press the **ENTER** key.
6. Use the **↑** and **↓** keys to scroll to “User Defined”. Press the **ENTER** key.
7. Press the **ESC** 2 times to get to the System Status Screen.

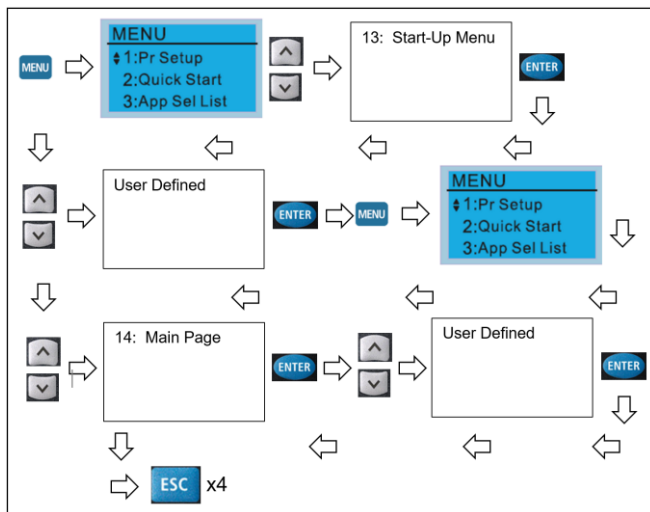

Figure 10-4. Accessing Rain Bird User Menu.

Rain Bird Main Menu

The Rain Bird Main Menu includes the selections shown in Figure 10-5. Use the **F1**, **F2** and **F3** keys to select from the Rain Bird Main Menu.

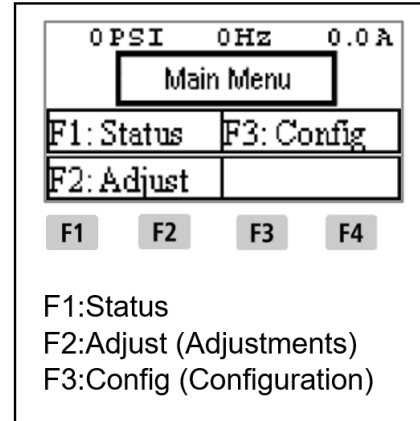

Figure 10-5. Rain Bird Main Menu.

VFD Main Menu

The VFD Main Menu includes the selections shown in Figure 10-6. Use the **↑** and **↓** keys to select from the VFD Main Menu.

1: Parameter Setup	9: Keypad Locked
2: Quick Start	10: PLC Function
3: Application Selection List	11: Copy PLC
4: Changed List	12: Display Setup
5: Copy Parameter	13: Start-Up Menu
6: Fault Record	14: Main Page
7: Language Setup	15: PC Link
8: Time Setup	16: Start Wizard

Figure 10-6. VFD Main User Menu.

Pump Station Input / Output Status (I / O)

The pump station input and output status can be checked by pressing the **F2** I / O key when in the System Status screen. Pressing **F4** Next key will cycle through the screens. Open circles next to an input or output indicates an OFF state. A darkened circle next to an input or output indicates an ON state. See Figure 10-7.

10 OPERATOR INTERFACE

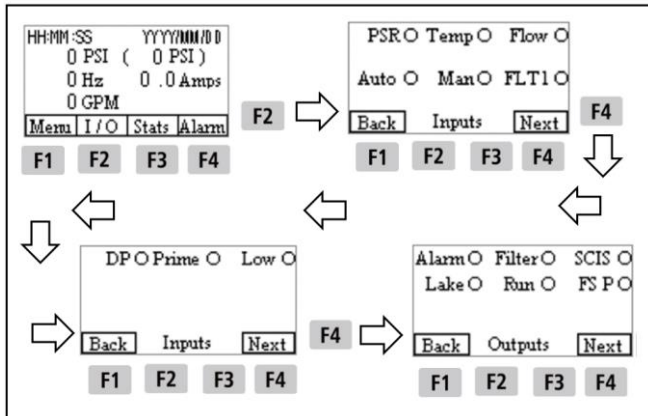

Figure 10-7. Checking Input / Output Status.

Station Statistics (Stats)

The pump station System Statistics can be accessed by pressing the **F3** Stats key in the System Status screen. While in the Statistics screen, pressing the **F3** R-kW key will reset the accumulated kilowatt hours used. Pressing the **F4** PLC key will access the PLC scan time statistics. See Figure 10-8.

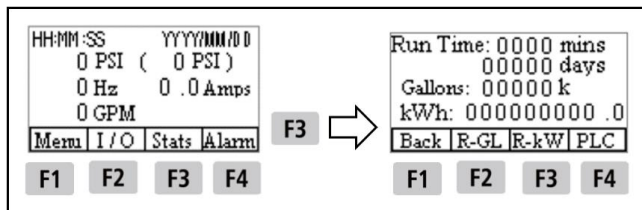

Figure 10-8. Checking Pump Station Statistics.

CLP pump stations are not equipped with flow meters, thus the accumulation of flow through the pump station will not be shown (Gallons).

11 SETTING VARIABLE FREQUENCY DRIVE PARAMETERS

General



The Variable Frequency Drive (VFD) parameters may be accessed and set by the user. See **Appendix D – Default VFD Parameters** for a list of VFD parameters and their default values. Refer to the Variable Frequency Drive Manual for detailed information regarding accessing and setting parameters.

Adjusting System Settings

Changing VFD parameters is done when the Auto-Off-Manual (AOM) switch (E, Figure 4-1) is in the OFF position.

Adjustments to the pump station configuration are done by one of two methods depending upon the type of setting to be changed.

Method 1

If the settings in the menu screen appear as in Figure 11-1, the settings can be changed by pressing the **F3** key for +, which sets that parameter to ON, indicated by a darkened circle next to the parameter. Pressing the **F2** key for – sets that parameter OFF, indicated by an open circle next to the parameter. Use the  key to advance to the next parameter, or the  key to go back to the previous parameter. Figure 11-1 shows an example for changing Wake settings.

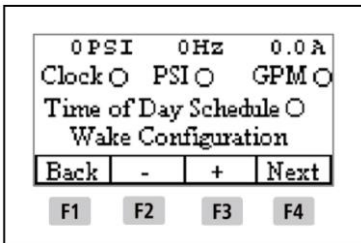

Figure 11-1. Method 1 – Adjusting System Settings.

Use the **F4** Next key to advance to the next screen, or use the **F1** Back key to return to the previous screen.

Method 2

If the settings in the menu screen appear as in Figure 11-2, select the item to be changed with the **F2**, **F3** or **F4** keys.

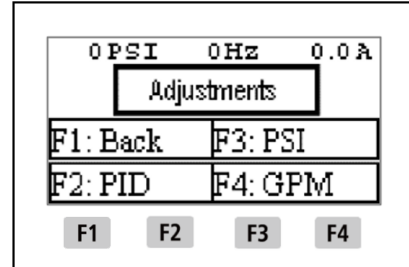

Figure 11-2. Method 2 – Adjusting System Settings.

In this example, selecting **F3**, PSI, will bring up the pressure setting screen (see Figure 11-3).

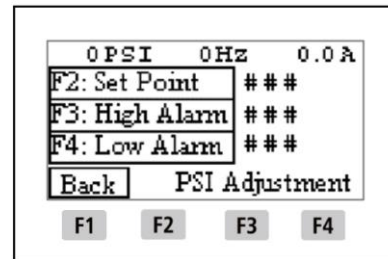







Figure 11-3. Screens Requiring Numerical Values.

Continuing with this example, select the pressure to be changed with the **F2**, **F3** or **F4** keys. The numerical value can then be changed using the arrow keys. Use the  or  keys to increase or decrease the numerical value of the first digit of the number. Use the  key to proceed to the next digit. Again, use the Up / Down arrow keys to increase or decrease numerical value of the number. Proceed to the next digit with the  key and repeat this process. The  key is used to move back to the previous digit if necessary. When finished setting the number, press the  key to save the new value. Use the **F1** Back key to return to the previous screen.

12 INITIAL START-UP GUIDE

General

The Initial Start-Up Guide is intended to get the Compact Low Profile Rapid Ship (CLPRS) pump station operational quickly. It is not intended to be comprehensive instructions regarding all the parameter settings for the pump station. Refer to the Variable Frequency Drive (VFD) Manual for complete instructions regarding the VFD.

Before beginning start-up of the pump station, read and follow the information in **2 Safety Information** section of this manual.

Should you have any questions regarding the initial start-up of the pump station, contact Rain Bird Global Service Plan (GSP) support. See **1 Introduction** for contact information. Note the CLPRS Model and the Job Number found on the Job Information label inside the pump station enclosure on the left side (see Figure 6-3), and have this information ready when calling for support.

Access To Pump Station Internal Equipment

To perform the procedures in this section, you must access to the pump station internal equipment. To do so, the pump station hood must be raised and, if necessary, the front cover can be removed. The front cover must be re-installed and the hood closed when the work is completed.

To gain access to the pump station internal equipment:



Leaving the hood in the raised position without engaging the retractable spring plunger pin could allow the hood to come down on top of anyone working under it, which could result in death or serious injury. Always engage the retractable spring plunger pin in the hole adjacent to the hinge pin.

1. Raise the pump station hood. Ensure that the retractable spring plunger pin on the left side of the enclosure near the hinge pin is engaged in the hole adjacent to the hinge pin on the cover. See Figure 5-2.

2. If it is necessary to remove the front cover, remove the six screws located on the inside of the pump station enclosure and lift the front cover away from the flanges on either side of the enclosure. See Figure 5-3.

When work inside the pump enclosure is completed:

1. Re-install the front cover by placing the cover in the flanges on either side of the pump station enclosure. Secure the front cover by re-installing the six screws in the holes located inside the pump station enclosure. See Figure 5-3.

NOTICE

Attempting to close the pump station hood without first disengaging the retractable spring plunger pin from the hole adjacent to the hinge pin will result in damage to the retractable spring plunger pin or hinge area. Always pull the knob of the retractable spring plunger and ensure that the plunger pin has disengaged from the hole adjacent to the hinge pin before closing the hood.



Disengaging the retractable spring plunger pin from the hole adjacent to the hinge pin without having a firm grip on the pump station hood could result in death or serious injury. Always have a firm grip on the pump station hood before disengaging the retractable spring plunger pin from the hole adjacent to the hinge pin.

2. Have a firm grip on the pump station hood with one hand, while pulling the knob of the retractable spring plunger on the left side of the enclosure near the hinge pin with the other. Disengage the plunger pin from the hole adjacent to the hinge pin before lowering the hood. See Figure 5-2.

Pump Motor Bearings

The pump motor shaft may need to be rotated or the pump motor bearings may need to be lubricated prior to pump station start-up.

Check the manufacture date on the label on the left side of the pump station enclosure. If 90 days or longer has elapsed since the pump station was

12 INITIAL START-UP GUIDE

manufactured, the pump motor shaft must be rotated by hand to ensure that the shaft rotates freely, and the pump motor bearings are properly lubricated.

If 6 months or longer has elapsed since the pump station has been manufactured, the pump motor bearings may need to be greased before starting the pump. See Greasing The Pump Motor Bearings in **15 Maintenance** section.

To rotate the pump motor shaft prior to pump station start-up:

1. Set the AOM Switch (E, Figure 4-1) in the OFF position. See Figure 6-2.



Working with electrically energized components in the pump station enclosure will result in death or serious injury. Always make sure the Fused Electrical Disconnect on the pump station is OFF, and that proper Lockout / Tagout procedures are followed before beginning work on the pump motor.

2. Verify that the Fused Electrical Disconnect (P, Figure 4-2) on the pump station is OFF. The handle must be in the down position. Use proper Lockout/Tagout procedures. See Figure 6-1.
3. Remove the 3 screws securing the fan cover to the end of the pump motor. See Figure 12-2. Rotate the pump motor shaft as follows:



Using pliers, vice-grips or similar tools to rotate the pump motor shaft can result in damage to the pump motor fan, bearings or shaft. Always rotate the pump motor shaft by hand.

- a. Rotate the fan by hand 15 revolutions. DO NOT use pliers, vice-grips or similar tools to rotate the pump motor shaft.
- b. Re-install the fan cover on the pump motor using the 3 screws.

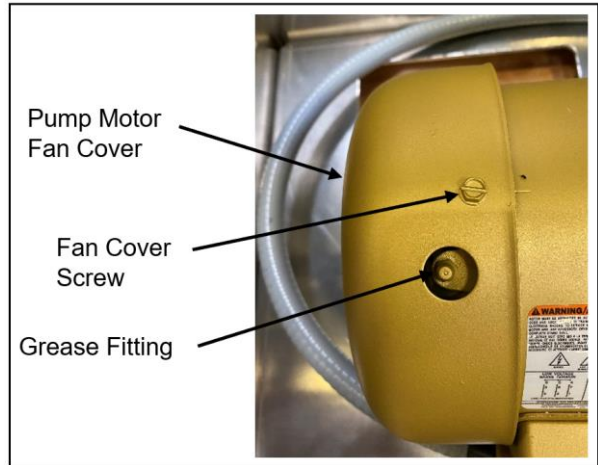

Figure 12-2. Pump Motor Fan Cover.

Checking Pump Station Voltage

Check that the CLPRS pump station is programmed to the correct voltage. The pump station should come from the factory with the voltage set in the VFD, but it must be checked and verified. The voltage will be as stated on the Job Information Label (see Figure 6-3). Refer to Figure 10-1 for location of Operator Interface components.

To verify the pump station voltage setting in the VFD:

1. Set the AOM Switch (E, Figure 4-1) in the OFF position. See Figure 6-2.
2. Apply electrical power to the pump station by setting the Fused Electrical Disconnect on the pump station to ON. The handle must be in the up position. See Figure 12-3.

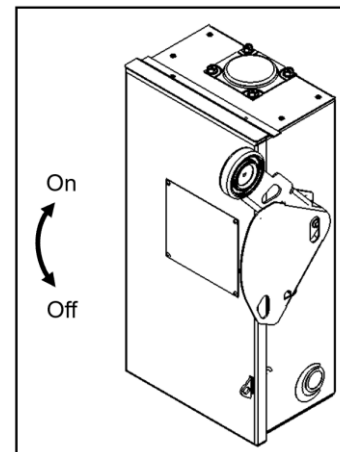

Figure 12-3. Fused Electrical Disconnect.

12 INITIAL START-UP GUIDE

3. Press the **MENU** key to get to the VFD Menu (see Figure 12-4).
4. Use the **↑** and **↓** keys to scroll to option 1: Pr Setup menu. Press the **ENTER** key (see Figure 12-4).
5. Use the **↑** and **↓** keys to scroll to “Parameter Group 01: Basic Parameters”. Press the **ENTER** key (see Figure 12-4).
6. Use the **↑** and **↓** keys to scroll to Parameter 02: MAX Out-VOLT 1. Press the **ENTER** key (see Figure 12-4).
7. Verify that the voltage stated matches the pump station Job Information label (see Figure 6-3) and the available site power (Table 6-1).

NOTICE

Operating the pump station with the incorrect voltage setting in the VFD will result in damage the VFD, Centrifugal Pump or other components of the pump station. Always check and verify that the voltage set in the VFD is correct for the available site power.

8. If the voltage set in the VFD is not as stated on the Job Information Label, **DO NOT PROCEED FURTHER**. Contact Rain Bird Global Service Plan (GSP) support. See **1 Introduction** for contact information.
9. If the voltage is correct, press the **ESC** 4 times to get to the System Status Screen.

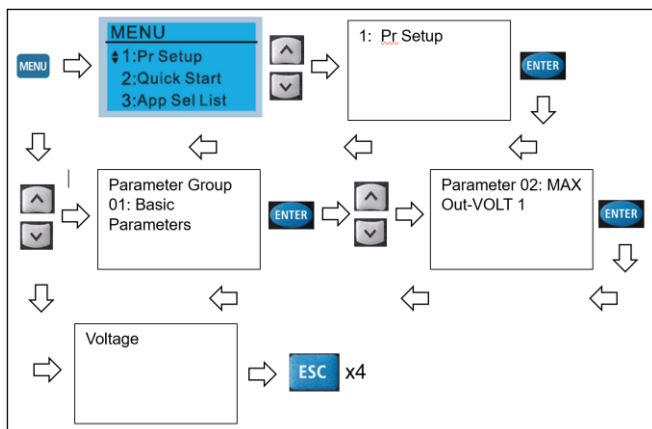

Figure 12-4. Checking Pump Station Voltage.

If a VFD alarm is present, pressing the **ESC** key will allow access to the System Status screen. Follow the procedure in System And Variable Frequency Drive Alarms in **13 System Alarms And Faults** section.

Setting The System Clock

When the pump station is initially powered on, or when the power has been off for more than 7 days, the VFD Operator Interface will display a warning that the Real-Time Clock (RTC) needs to be set (see Figure 12-5).

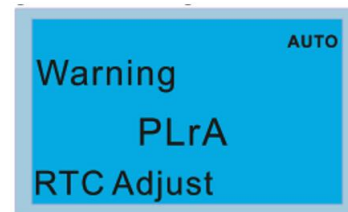

Figure 12-5. Warning To Set The Real-time Clock.

To set the Real-Time Clock:

1. Set the AOM Switch (E, Figure 4-1) in the OFF position. See Figure 6-2.
2. Press the **MENU** key to access the VFD Menu (see Figure 12-6).
3. Use the **↑** and **↓** keys to scroll to 8: Time Setup. Press the **ENTER** key to select (see Figure 12-6).

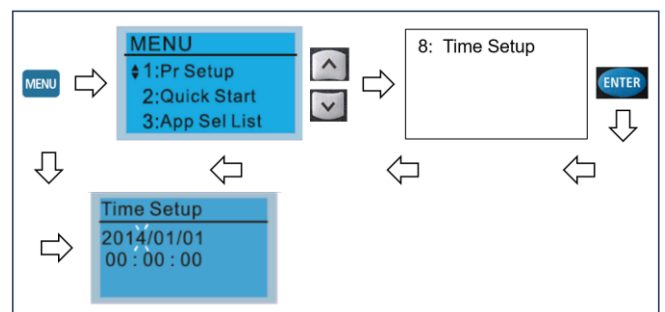







Figure 12-6. Accessing Real-Time Clock Set-Up.

4. The date is set first. The date is Year / Month / Day. The last digit of the Year will flash. Use the **↑** and **↓** keys to set the year (see Figure 12-7).

12 INITIAL START-UP GUIDE

5. Use the  and  keys to select the Year, Month, Day, Hour, Minute or Second. The selected parameter will flash when selected (see Figure 12-7). **NOTE!** The clock is a 24-hour clock.
6. Using the  and  keys, set the correct Year, Month, Day, Hour, Minute or Second (see Figure 12-7).
7. When complete, press the  key to confirm the Time Setup. See Figure 12-7.
8. Press the  key to return to the Rain Bird Menu.
9. Once the time and date have been set, turn the power to the pump station OFF by setting the handle on the Fused Electrical Disconnect (P, Figure 4-2) in the Down position. See Figure 6-1.
10. After approximately 15 seconds, turn the power to the pump station ON, by setting the handle on the Fused Electrical Disconnect in the up position. See Figure 12-3.

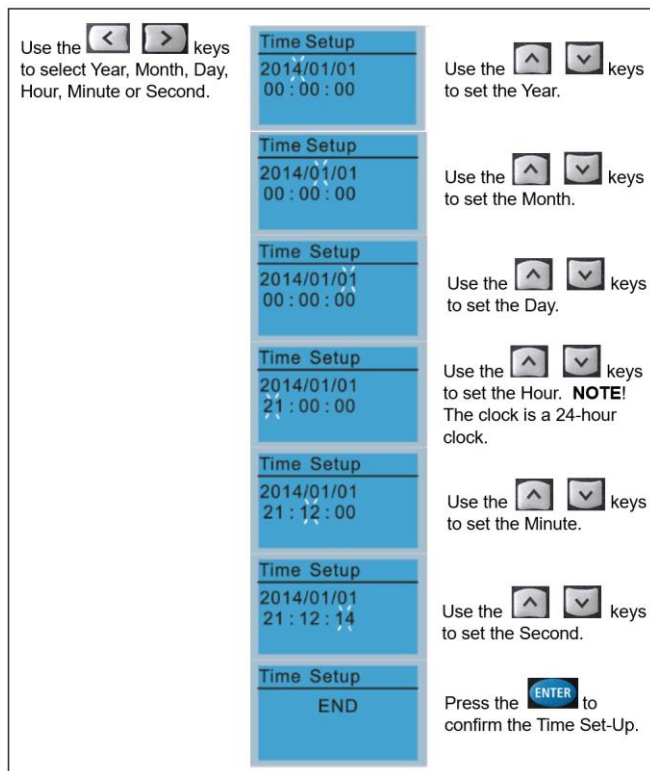

Figure 12-7. Completing The Time Setup.

Setting Pump Pressure Set Point

Generally, the pump pressure Set Point and High and Low Pressure Alarms are set at the factory. However, you may wish to check or adjust these settings.

To set the pump pressure Set Point and High and Low Pressure Alarms:

1. Open the Discharge Ball Valve (C, Figure 4-1) by placing the handle controlling the valve butterfly parallel to the discharge piping. See Figure 12-8.

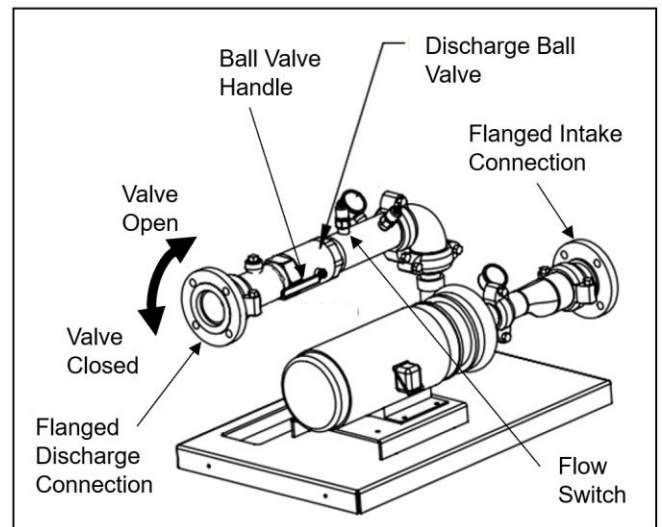

Figure 12-8. Discharge Ball Valve.

NOTICE

Adjusting the pump pressure Set Point outside the capabilities of the pump as shown on the pump flow curve label (see Figure 12-9) can result in damage to the pump. Always maintain the pump pressure Set Point within the capabilities of the pump.

12 INITIAL START-UP GUIDE

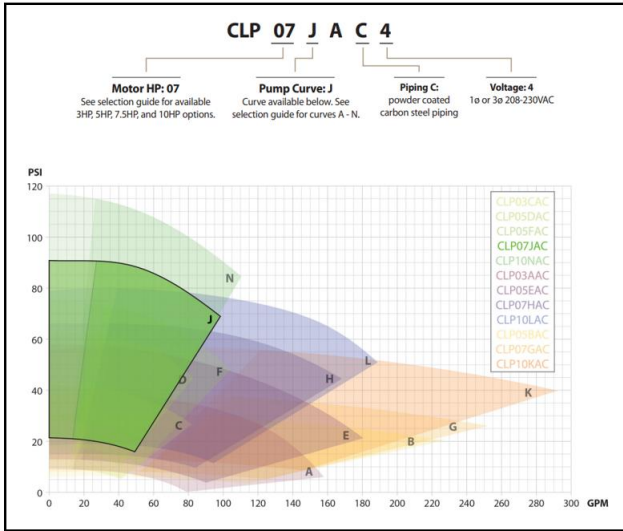

Figure 12-9. Example Of Pump Flow Curve.

2. Set the AOM Switch (E, Figure 4-1) in the OFF position. See Figure 6-2.
3. From the System Status screen, press the **F1** Menu key to get to the Rain Bird Main Menu screen (see Figure 12-10).
4. From the Rain Bird Main Menu screen, press the **F2** Adjust key to get to the Adjustments menu (see Figure 12-10).
5. Press the **F3** PSI key to get to the PSI Adjustment screen (see Figure 12-10).
6. Change the following settings using Method 2 outlined in **11 Setting Variable Frequency Drive Parameters** section:
 - a. The number to the right of F2: Set Point is the pump pressure Set Point. Adjust as necessary.
 - b. The number to the right of F3: High Alarm is the High Pressure Alarm. Adjust as necessary.
 - c. The number to the right of F4: Low Alarm is the Low Pressure Alarm. Adjust as necessary.
7. Be sure to save the new values by pressing the **ENTER** key when finished.

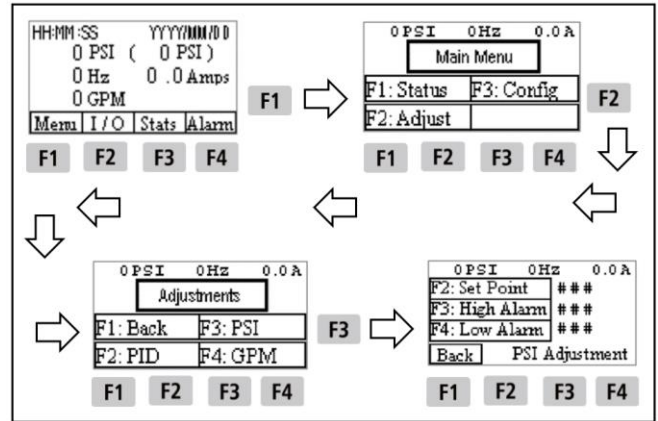

Figure 12-10. Adjusting The Pump Pressure Set Point.

8. Press the **F1** key 3 times to return to the System Status screen.

Pipe Fill Mode

The Pipe Fill Mode allows the pump station to fill the irrigation system slowly when the pump is started. Generally, this mode is disabled, unless this function is desired to reduce stress on the irrigation system due to water hammer.

To enable or disable the Pipe Fill Mode:

1. Set the AOM Switch (E, Figure 4-1) in the OFF position. See Figure 6-2.
2. From the System Status screen, press the **F1** Menu key to get to the Rain Bird Main Menu screen (see Figure 12-11).
3. From the Rain Bird Main Menu screen, press the **F3** Config key to get to the Configure menu (see Figure 12-11).
4. Press the **F3** PSI key to get to the Wake / Sleep screen (see Figure 12-11).
5. Press the **F4** Pipe Fill key to get to the Pipe Fill Enabled / Disabled screen (see Figure 12-11).
 - a. To disable the Pipe Fill Mode, press the **F2** Disbl key.
 - b. To enable the Pipe Fill Mode, press the **F3** Enbl key.

12 INITIAL START-UP GUIDE

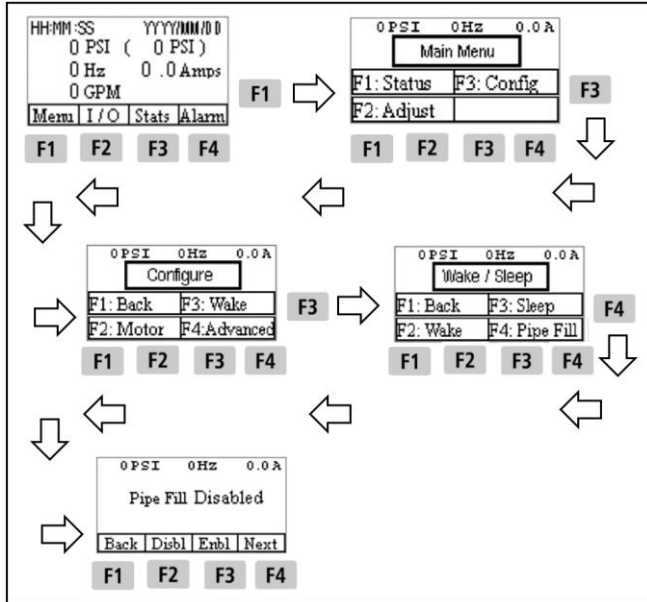

Figure 12-11. Adjusting Parameters For Pipe Fill Mode.

6. Adjust the parameters for the Pipe Fill Mode. All Pipe Fill settings may be changed using Method 2 outlined in **11 Setting Variable Frequency Drive Parameters** section. From the Pipe Fill Enable / Disable screen, press the **F4** Next key to get to the first Pipe Fill screen (see Figure 12-12).
 - a. The number to the right of F2: Low PSI is the low pressure threshold at which the Pipe Fill Mode will activate. Adjust as necessary.
 - b. The number to the right of F3: Fill Speed is frequency at which the VFD will run when activated. Adjust as necessary.
 - c. Be sure to save the new values by pressing the **ENTER** key when finished.
7. From the first Pipe Fill screen, press the **F4** Next key to get to the second Pipe Fill screen (see Figure 12-12).
 - a. The number to the right of F2: Fill Time is the time allotted for filling the irrigation system. Adjust as necessary.
 - b. The number to the right of F3: Fill Accel (Fill Acceleration) is an alternate pump acceleration time when the Pipe Fill mode is active allowing for the system to ramp up to speed at a slower rate. Adjust as necessary.

- c. Be sure to save the new values by pressing the **ENTER** key when finished.

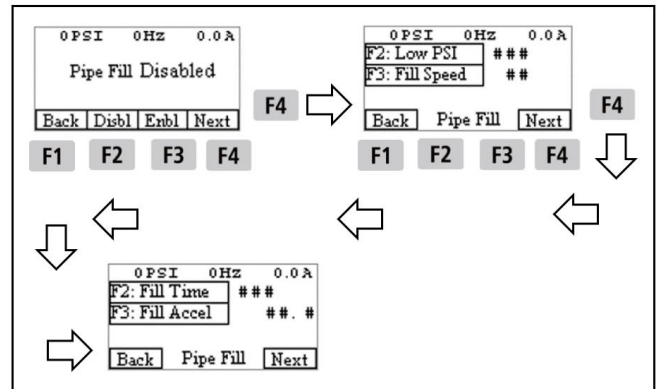

Figure 12-12. Adjusting Pipe Fill Parameters.

8. Press the **F1** key 6 times to return to the System Status screen.

Start / Wake Configuration

An input signal is required to wake or start the pump station. There are three ways to wake or start the pump station. These are:

- **Flow Start** – This type of start system requires the VFD to receive a signal from the Flow Switch to detect water flow. The system will wake when flow is detected. Flow Start systems require a pressurized water source, and will not work in Suction Lift applications (see **Appendix A – Pump Intake Applications**).
- **Clock Start** – This system requires the Pump Start Relay to receive a signal from an external irrigation controller. The system will wake when a start signal is present.
- **Time Of Day Start** – The system will wake at a specific time of day set in the VFD. One time per day can be set. The duration of the event may extend into the next day.

Combinations of inputs may be used to wake the system. For combinations such as Clock Start and Time Of Day Start, conditions set for both must be met. If all three wake settings are enabled, the system will only start if it receives a signal from the irrigation controller during the Time Of Day schedule AND there is flow through the pump station as detected by the Flow Switch.

12 INITIAL START-UP GUIDE

NOTE! – Pressure Start is not suitable for the CLPRS pump station as it is not equipped with a check valve to maintain pump pressure with the pump off.

Flow Start – To configure the pump station for Flow Start:

1. If Flow Start is desired, the CLPRS includes a factory installed Flow Switch (Q, Figure 4-2) with the pump station on the discharge pipe. See Figure 12-8.
2. Set the AOM Switch (E, Figure 4-1) in the OFF position. See Figure 6-2.
3. From the System Status screen, press the **F1** Menu key to get to the Rain Bird Main Menu screen (see Figure 12-13).
4. From the Rain Bird Main Menu screen, press the **F3** Config key to get to the Configure menu (see Figure 12-13).
5. Press the **F3** Wake key to get to the Wake / Sleep menu (see Figure 12-13).
6. Press the **F2** Wake key to get to the Wake Configuration screen (see Figure 12-13).

8. Press the **F4** Next key to get to the first Wake Configuration settings screen (see Figure 12-14).
9. Do not change PSI Drop as it is not applicable for Flow Start.
10. From the first Wake Configuration settings screen, press the **F3** Flow Start key. The number to the right of F3 Flow Start is used to set the Flow Switch. This setting may be changed using Method 2 outlined in **11 Setting Variable Frequency Drive Parameters** section. For a Flow Switch, set the number at 1. A Flow Switch is either ON (1) or OFF (0).
11. From the first Wake Configuration settings screen, press the **F4** Next key to advance to the second Wake Configuration screen (see Figure 12-14).
12. Do not change PSI Time as it is not applicable for Flow Start.
13. From the second Wake Configuration settings screen, press the **F3** GPM Time key. The number to the right of F3 GPM Time is the time during which the flow must occur before starting the pump (such as 5 seconds). This setting may be changed using Method 2 outlined in **11 Setting Variable Frequency Drive Parameters** section.

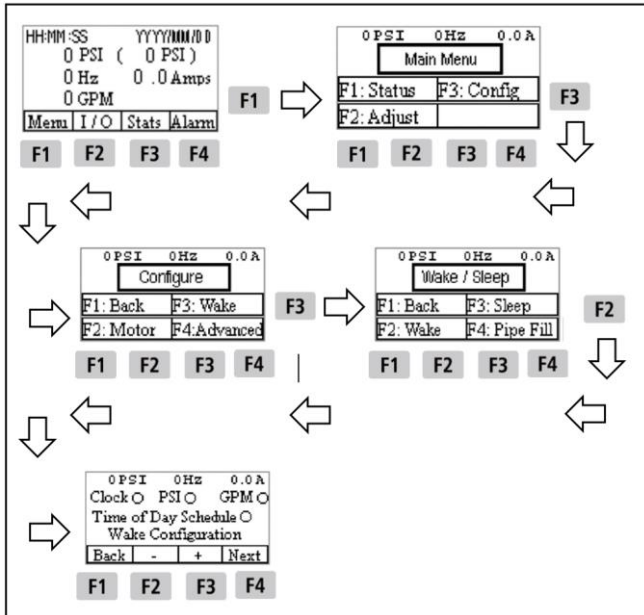

Figure 12-13. Configuring The System Flow Start.

7. Darken the circle next to GPM to set wake for Flow Start. This setting may be changed using Method 1 outlined in **11 Setting Variable Frequency Drive Parameters** section.

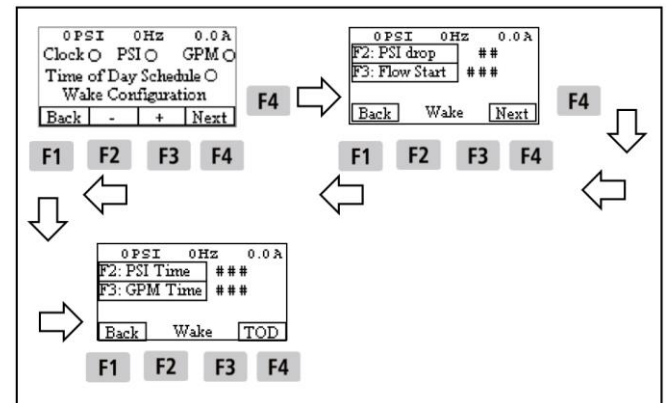

Figure 12-14. Adjusting Wake Parameters.

14. Be sure to save the new values by pressing the **ENTER** key when finished.
15. Press the **F1** Back key 6 times to return to the Wake / Sleep screen.

Clock Start – To configure the pump station for Clock Start:

12 INITIAL START-UP GUIDE

1. An irrigation controller will need to be wired to the Pump Start Relay. See Connecting An Irrigation Controller in **7 Connecting An External Input** section.
2. Set the AOM Switch (E, Figure 4-1) in the OFF position. See Figure 6-2.
3. From the System Status screen, press the **F1** Menu key to get to the Rain Bird Main Menu screen (see Figure 12-13).
4. From the Rain Bird Main Menu screen, press the **F3** Config key to get to the Configure menu (see Figure 12-13).
5. Press the **F3** Wake key to get to the Wake / Sleep screen (see Figure 12-13).
6. Press the **F2** Wake key to get to the Wake Configuration screen (see Figure 12-13).
7. Darken the circle next to Clock to set wake for Clock Start. This setting may be changed using Method 1 outlined in **11 Setting Variable Frequency Drive Parameters** section.
8. Be sure to save the new values by pressing the **ENTER** key when finished.
9. Press the **F1** Back key 4 times to return to the System Status screen.
10. Program the irrigation controller per the manufacturer's manual.
11. The irrigation controller signal may be checked from the System Status screen (see Figure 12-15). Press the **F2** I / O key to get to the Inputs screen.

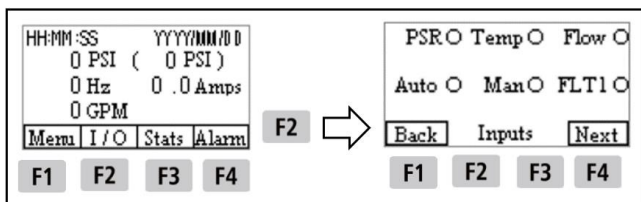

Figure 12-15. Checking The Signal From The Irrigation Controller.

12. If the circle next to PSR (Pump Start Relay) is darkened, the signal from the irrigation controller is being received by the VFD. When the signal from the irrigation controller stops, the circle next to PSR will be open, and the VFD will stop the pump.

Time Of Day Start – To configure the pump station for Time Of Day Start:

1. Set the AOM Switch (E, Figure 4-1) in the OFF position. See Figure 6-2.
2. From the System Status screen, press the **F1** Menu key to get to the Rain Bird Main Menu screen (see Figure 12-13).
3. From the Rain Bird Main Menu screen, press the **F3** Config key to get to the Configure menu (see Figure 12-13).
4. Press the **F3** Wake key to get to the Wake / Sleep screen (see Figure 12-13).
5. Press the **F2** Wake key to get to the Wake Configuration screen (see Figure 12-13).
6. Darken the circle next to Time Of Day Schedule to set wake for Time Of Day Start. This setting may be changed using Method 1 outlined in **11 Setting Variable Frequency Drive Parameters** section.
7. The active period in which irrigation will occur is individually configurable for each day of the week beginning on Sunday. The period is defined by the start time on the first screen, the run time on the next screen and a review of the start time and run time on the third screen for that particular day of the week.
8. From the Wake Configuration screen, press the **F4** Next key to get to the Sunday start time screen (see Figure 12-16). Set the start time using Method 2 outlined in **11 Setting Variable Frequency Drive Parameters** section.
 - a. Press the **F2** Start Hr key to set the start hour to begin irrigation. Start time hours are based on a 24 hour clock (0=12AM and 23=11PM). Example: for a 2 PM start time, set Start Hr for '14'.
 - b. Press the **F3** Start Min to set the start minutes. Example: for a 2:30 PM start time, set Start Min for '30'.
9. Press the **F4** Next key to get to the Sunday run time screen (see Figure 12-16). Set the duration using Method 2 outlined in **11 Setting Variable Frequency Drive Parameters** section.
 - a. Press the **F2** Run Hours key to set the number of hours of irrigation time. Example: for a 3 hours of irrigation, set Run Hours for '03'.

12 INITIAL START-UP GUIDE

- b. Press the **F3** Run Mins to set the number of minutes. Example: for a 3:15 of irrigation time, set Run Mins for '15'.
10. Press the **F4** Next key to get to the Sunday review screen (see Figure 12-16) showing the start time and the run time for Sunday.

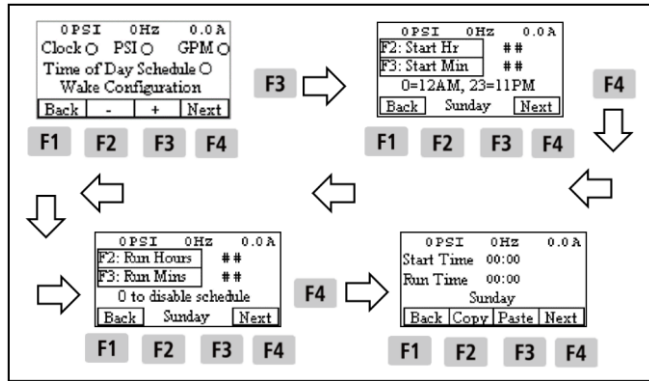

Figure 12-16. Setting Time Of Day Start Active Periods.

- 11. Certain days of the week may have the same start time and run time. This may be accomplished quickly with the Copy / Paste functions. See Figure 12-17. Example: Sunday and Monday have the same start time and run time:
 - a. From the review screen of the day you wish to copy (Sunday), press the **F2** Copy key to copy the start time and run time.
 - b. Press the **F4** Next key 3 times to get to the review screen for the next day (Monday). If the day you wish to copy the start and run times to is a later day in the week, press the **F4** Next key as many times as necessary to get to the review screen for that particular day.
 - c. Press the **F3** Paste key to insert the start time and run time on that day (Monday).
 - d. Repeat Steps 11b and 11c for each day to have the same start time and run time.

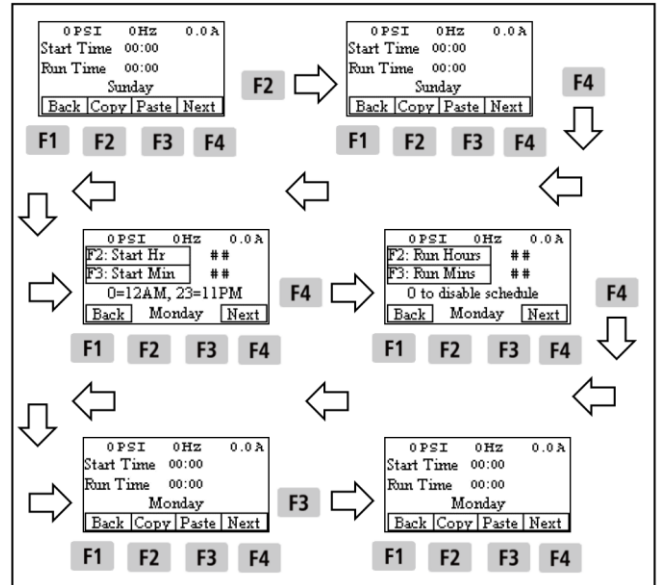

Figure 12-17. Copying Time Of Day Start Times To Another Day.

- 12. For days that have a different start time and run time, repeat Steps 8, 9 and 10.
- 13. For days when no irrigation is needed, the Run Hour and Run Minute values on the Start Time screen should be set to '00'.
- 14. Be sure to save the new values by pressing the **ENTER** key when finished.
- 15. After completing the final setting screen for Saturday, press the **F4** Done key to return to the Wake / Sleep screen. Then press the **F1** Back key 3 times to return to the System Status screen.

Sleep Configuration

Parameters for pump station Sleep configuration need to be set regardless of the pump station Start mode.

To configure the pump station Sleep:

1. Set the AOM Switch (E, Figure 4-1) in the OFF position. See Figure 6-2.
2. From the System Status screen, press the **F1** Menu key to get to the Rain Bird Main Menu screen (see Figure 12-18).
3. From the Rain Bird Main Menu screen, press the **F3** Config key to get to the Configure menu (see Figure 12-18).

12 INITIAL START-UP GUIDE

- Press the **F3** Wake key to get to the Wake / Sleep screen (see Figure 12-18).
- Press the **F3** Sleep key to get to the first Sleep configuration settings screen (see Figure 12-18).

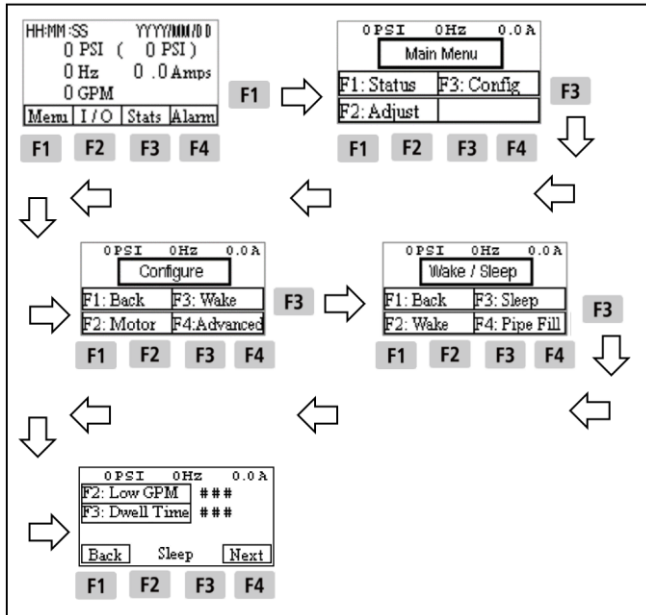

Figure 12-18. Setting Sleep Parameters.

- All Sleep Configuration settings may be changed using Method 2 outlined in **11 Setting Variable Frequency Drive Parameters** section.
- The Low GPM setting is the minimum flow at which the VFD will perform a sleep test. To adjust the Low GPM setting, from the first Sleep configuration settings screen, press the **F2** Low GPM key (see Figure 12-19). The number to the right of F2 Low GPM can be used for the Flow Switch. For a Flow Switch, set the number at 1.
- The Dwell Time is the time allotted at the Low GPM flow before the VFD performs a sleep test (such as 10 seconds). To adjust the Dwell Time setting, from the first Sleep configuration settings screen, press the **F3** Dwell Time key. The number to the right of F3 Dwell Time can be adjusted (see Figure 12-19).
- Press the **F4** Next key to get to the second Sleep configuration settings screen (see Figure 12-19).
- During the sleep test, the VFD will signal the pump to run at the pump pressure Set Point

plus the Boost Pressure at minimum speed. To adjust the Boost Pressure setting, from the second Sleep Configuration settings screen, press the **F2** Boost PSI key (see Figure 12-19). The number to the right of F2 Boost PSI can be adjusted. The default Boost PSI setting for the CLPRS pump station will be 0. This setting will shut down the pump when flow is below the Flow Switch threshold.

- The Test Timer is not applicable to CLPRS pump stations, and should be set to 1. To adjust the Test Timer setting, from the second Sleep configuration settings screen, press the **F3** Test Timer key. Adjust the number to the right of F3 Test Timer to 1 (see Figure 12-19).
- Press the **F4** Next key to get to the third Sleep configuration settings screen (see Figure 12-19).
- The Retest Time is not applicable to CLPRS pump stations, and should be set to 1. To adjust the Retest Time setting, from the first Sleep Configuration settings screen, press the **F2** Retest Time key. Adjust the number to the right of F3 Test Timer to 1 (see Figure 12-21).
- The Max Retest is not applicable to CLPRS pump stations, and should be set to 1. To adjust the Max Retest setting, from the first Sleep Configuration settings screen, press the **F3** Max Retest key. Adjust the number to the right of F3 Test Timer to 1 (see Figure 12-21).

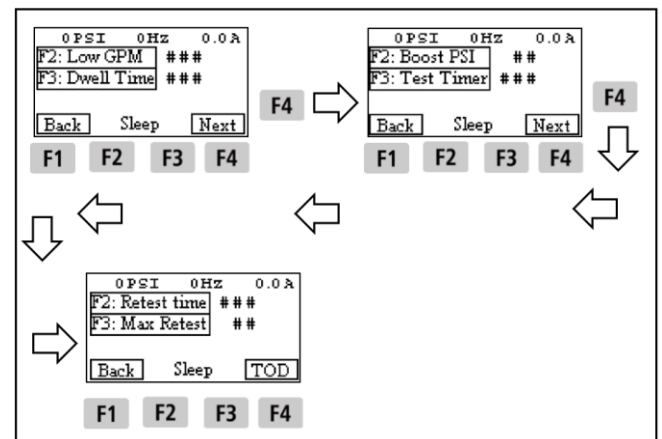

Figure 12-19. Adjusting Sleep Parameters.

- Be sure to save the new values by pressing the **ENTER** key when finished.

12 INITIAL START-UP GUIDE

16. Press the **F1** Back key 5 times to return to the System Status screen.

Checking Pump Station Operation

After setting all of the pump station parameters outlined in this section, the pump station should be tested to ensure proper operation.

To check that the pump station operating properly:

1. Verify that the VFD will run the pump. Momentarily set the AOM Switch (E, Figure 4-1) to MANUAL to make sure the pump starts and runs. If the pump does not run, see **14 Troubleshooting** section and correct any problems before continuing.

NOTICE

On initial start-up of the pump, Rain Bird recommends that the sprinklers be turned on or that the heads be removed from the risers to assist in venting air from the irrigation zones. This will also prevent an overpressure alarm.

2. If the system is set to operate on Clock Start, program the irrigation controller so the pump station will start. See Clock Start instructions in Start / Wake Configuration in this section. If the system is set to operate on Time Of Day Start, program the pump station so it will start. See Time Of Day Start instructions in Start / Wake Configuration in this section.
3. Set the AOM switch to AUTO. The pump will run to bring the pressure up to the pump

Dynamic Inlet Pressure

- pressure Set Point.
- a. Verify that the pump starts and runs, and that it pressurizes the discharge line and irrigation connections.
 - b. Once all air has been vented from the irrigation zones, ensure that all risers and heads at high points are shut.
4. Perform a shutdown test with all irrigation off.
 - a. Verify that the VFD reduces the pump speed to not exceed the pump pressure Set Point.

- b. If the pump continues to run while not irrigating, check for leaks in the irrigation field. Refer to the **14 Troubleshooting** section and correct any problems before continuing.
5. Test each irrigation zone and observe operating conditions to determine flow conditions. The VFD should be operating between 35 and 60 Hz, and pressure should be maintained at the pump pressure Set Point.
 - a. Start with the irrigation zone with the lowest flow. When the system has stabilized, check the System Status screen and observe the system pressure (PSI) and the frequency (Hz) indicated on the Operator Interface Monitor.
 - b. If the frequency is less than 35 Hz, but the zone is maintaining the pump pressure Set Point, the zone is demanding too little flow. Add flow to the zone to bring the frequency above 35 Hz.
 - c. If the frequency is 30 Hz, and system pressure is at or above the pump pressure Set Point, the zone is too small. Combine the zone with another low-flow zone. If the pump station is in a Pressure Boost application (see **Appendix A – Pump Intake Applications**), it may be possible to run this zone with dynamic inlet pressure alone with the pump off.
 - d. Operate the irrigation zone with the highest flow. When the system has stabilized, check the System Status screen and observe the system pressure (PSI) and the frequency (Hz) indicated on the Operator Interface Monitor.
 - e. While operating the irrigation zone with the highest flow, check the dynamic inlet pressure on the Intake Pressure Gauge on the Intake Pipe (see Figure 8-1). Record the pressure in Table 12-1.

Table 12-1. Dynamic Inlet Pressure.

- f. If the frequency is 60 Hz, and the system is not reaching the pump pressure Set Point, the zone is demanding too much flow. Either:

12 INITIAL START-UP GUIDE

- i. Reduce the flow in the zone until the VFD can maintain the pump pressure Set Point, at a frequency slightly lower than 60 Hz.

OR

- ii. Reduce the pump pressure Set Point, if the pump is operating outside the flow curve of the pump. See Figure 12-9.
6. While performing Step 4, note if alarms are occurring while irrigating a zone for longer than 2 minutes. See **13 System Alarms And Faults** section.

13 SYSTEM ALARMS AND FAULTS

General

The Variable Frequency Drive (VFD) monitors several alarm and fault functions that protect the VFD and the pump motor. If an alarm occurs, the red Pump Station Alarm Light (N, Figure 4-2) will illuminate, and the Operator Interface Monitor (A, Figure 10-1) will flash and display the fault code. The VFD will not run the pump while an alarm is active.

Should you have any questions regarding system alarms or faults for this pump station, contact Rain Bird Global Service Plan (GSP) support. See **1 Introduction** for contact information. Note the CLPRS Model and the Job Number found on the Job Information label inside the pump station enclosure on the left side (see Figure 6-3), and have this information ready when calling for support.

System And Variable Frequency Drive Alarms

The VFD records both System alarms related to pump station operation (Rain Bird configuration), and VFD alarms specific to the VFD (VFD configuration). From the System Status screen, press the **F4** Alarm key to open the first screen of System alarms. Pressing the **F4** Next key will proceed to the next screen of System alarms. Pressing the **F4** VFD key will access the VFD Alarm List. Pressing the **F4** Detail key will proceed to a screen showing how to get additional detail on VFD alarms. See Figure 13-1.

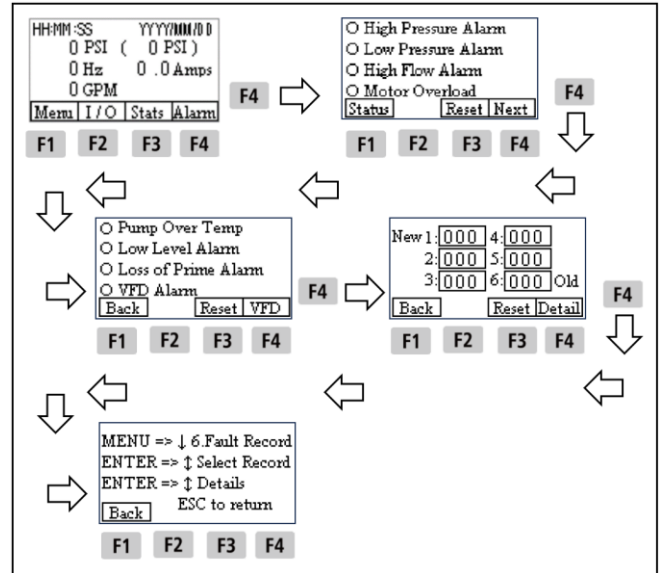

Figure 13-1. Accessing Alarm Screens.

If an alarm is active, the circle next to the alarm will be darkened.

Pressing the **F1** Back key will navigate back to the previous screen, and pressing the **F1** Back key 4 times will return you to the System Status screen.

Variable Frequency Drive Alarm History

The VFD will store the VFD alarm codes from the last 6 alarms, with the most recent alarm being item 1 on the list. Note that this is a historical list, and that the most recent VFD alarm may not be the current alarm. If there is a current VFD alarm, it will be indicated by the VFD Alarm status in the System Alarm screens. If active, the VFD Alarm will have the circle next to it darkened.

It may be necessary to verify the latest fault in the VFD Menu.

To verify a fault:

1. Press the **MENU** key to access the VFD Menu.
2. Using the **↑** or **↓** keys, navigate to 6: Fault Record.
3. Press the **ENTER** key to access the Fault Record.

13 SYSTEM ALARMS AND FAULTS

4. Check the time of the most recent fault, Fault 1.
5. If the fault was recent, it will require troubleshooting. If the fault was not recent, no further action is necessary.

Further information on alarms, fault details and troubleshooting are found in the VFD User Manual.

Clearing An Alarm

Before clearing or resetting an alarm, note the alarm shown on the Operator Interface Monitor.

To reset an alarm:

1. Set the Auto-Off-Manual (AOM) Switch (E, Figure 4-1) in the OFF position. See Figure 6-2.
2. Determine the reason or cause of the alarm and correct the problem.

3. After accessing the System Alarm list as stated in System And VFD Alarms, press the **F3** Reset key on the System Alarm screen to clear the alarm (see Figure 13-1).
4. If the alarm fails to reset, it is likely that the alarm conditions are still present. Repeat Steps 2 and 3.
5. Restart the pump station by setting the AOM switch to AUTO.

Common Alarms

The following are lists of common alarms for System Alarms and VFD Alarms. This is not intended to be a comprehensive list of all possible alarms. Refer to the VFD User Manual for additional information on alarms.

Before resetting any alarm, determine the reason or cause of the alarm and correct the problem.

Common Rain Bird System Alarms		
Alarm	Description	Possible Causes
High Pressure Alarm	Pump pressure is above the High Alarm setting for a period exceeding the High Alarm Duration setting.	<ul style="list-style-type: none"> • Excessive pressure variations or over pressure in the pump inlet system. • Excessive pressure variations in the pump discharge system. Tune PID as necessary. • Check for a master valve directly after the pump station discharge. If it is normally closed, ensure that Clock Start is enabled to wake the pump station, and that the irrigation controller is properly wired to the Pump Start Relay. • Alarm parameters require adjustment. Adjust as necessary.
Low Pressure Alarm	Pump pressure is below the Low Alarm setting while the pump operates at or near maximum speed for a period exceeding the Low Alarm Duration setting.	<ul style="list-style-type: none"> • Line breaks or leaks in the irrigation system. • Pump inlet pressure too low. • For Suction Lift applications, leak in intake piping or foot valve leak causing pump to lose prime. • Irrigation controller demanding more flow than the rated pump station capacity. • Alarm parameters require adjustment. Adjust as necessary.
High Flow Alarm	Measured flow exceeds Alarm Flow Setting. Requires a flow meter (pulse-frequency or analog) to check.	<ul style="list-style-type: none"> • Line breaks or leaks in the irrigation system. • Irrigation controller demanding more flow than the rated pump station capacity. • Alarm parameters require adjustment. Adjust as necessary.
Motor Overload	The pump motor demands more current than allowed, based on a service factor of 115%	<ul style="list-style-type: none"> • Flow rate exceeds pump curve runout. • Incoming power including voltage, phase and grounding exceeds 15 Ohms. Requires licensed electrician.

13 SYSTEM ALARMS AND FAULTS

	of rated Full Load Amps (FLA).	<ul style="list-style-type: none"> • Pump motor is not rotating freely. See Item 8 in 14 Troubleshooting section. • Pump discharge parameters set beyond capabilities of pump as stated on the Pump Flow Curve. • Acceleration time for the pump motor set to short. Increase Acceleration time.
Pump Over Temp	Pump volute over temperature switch exceeded 130° F (55° C).	<ul style="list-style-type: none"> • Verify positive input on System Status screen, I / O screen (darkened circle next to Temp). • Pump is dry-running¹, or for Suction Lift applications, leak in intake piping or foot valve leak causing pump to lose prime. • Pump is deadheading². • Alarm parameters require adjustment. Adjust as necessary.
Low Level Alarm	Optional Low Level Safety Float Switch indicates low water level in tank or pond.	<ul style="list-style-type: none"> • Optional Low Level Safety Float Switch is not installed – adjust Alarm Configuration parameters. • Optional Low Level Safety Float Switch is installed – verify positive input on System Status screen, I / O screen (darkened circle next to Low Level). • Water level at water source is low. Replenish as necessary.
Loss Of Prime Alarm	Optional Prime-Loss Sensor detects air in the suction system.	<ul style="list-style-type: none"> • Optional Prime-Loss Sensor is not installed – adjust Alarm Configuration parameters. • Optional Prime-Loss Sensor is installed – verify positive input on System Status screen, I / O screen (darkened circle next to Prime-Loss). • Intake system has lost prime. Re-prime the pump and evacuate all air from the intake system. See 8 Priming The Pump – Suction Lift Applications section.
VFD Alarm	One of many possible VFD faults has occurred.	See Common VFD Alarms And Faults below.

¹ Dry-running is a condition where the pump is operating with an inadequate supply of water.

² Deadheading is a condition where the pump is operating without an outlet for water.

Common VFD Alarms And Faults				
Alarm Code	Fault	Fault Name	Fault Description	Possible Causes
09	oH1	Overheat 1 Warning	Insulated-Gate Bipolar Transister (IGBT) over-heating warning occurs when IGBT temperature is higher than Pr. 06-15 setting.	<ul style="list-style-type: none"> • Ambient temperature has exceeded 120° F (49° C). • Fans on bottom of VFD are obstructed or are not operational.

13 SYSTEM ALARMS AND FAULTS

10	oH2	Overheat 2 Warning	An oH2 warning occurs when a board-level component temperature is higher than the oH2 warning level.	<ul style="list-style-type: none"> • Ventilation openings in pump station enclosure are blocked. • Exhaust fans (if installed) are obstructed or not operational.
17	oH2	Heatsink Overheat	The temperature of the heatsink in the VFD is too high.	
19	PHL	Input Phase Loss	One of the input phases to the VFD is unbalanced or open.	<ul style="list-style-type: none"> • Screw(s) securing wiring to the VFD are loose. See Problem No. 9 in 14 Troubleshooting section. • Incoming power including voltage, phase and grounding exceeds 15 Ohms. Requires licensed electrician.
20	ot1	Over Torque 1	Pump motor is overloading and exceeding 150% of VFD rated output.	<ul style="list-style-type: none"> • Ambient temperature has exceeded 120° F (49° C). • Fans on bottom of VFD are obstructed or are not operational. • Ventilation openings in pump station enclosure are blocked. • Exhaust fans (if installed) are obstructed or not operational.
21	ot2	Over Torque 2		
21	oL	Over Load		
22	oH3	Motor Overheat	The VFD detects the internal pump motor temperature is too high.	<ul style="list-style-type: none"> • Pump motor is not rotating freely. See Problem No. 8 in 14 Troubleshooting section. • Pump operating at low speed (≤ 30 Hz) for extended period of time. • Reduce Carrier Frequency (more audible pump motor noise). • Pump motor fan obstructed. Clear obstruction.
28	OPHL	Output Phase Loss	One of the output phases to the pump motor is open.	<ul style="list-style-type: none"> • Check wiring between VFD and pump motor. See Problem No. 10 in 14 Troubleshooting section.
47	PLrA	RTC Adjust	Real Time Clock is not adjusted. No power applied to the pump station for more than a week.	<ul style="list-style-type: none"> • Turn power OFF at Fused Disconnect Switch. Wait 30 seconds. Turn power ON. • If problem persists, set the date and time. See Setting The System Clock in 12 Initial Start-Up section.
01	ocA	Oc at acceleration	Output current exceeds 2.4 times rated current during acceleration.	<p>Note: the drive immediately stops the output and the pump motor runs freely.</p>
02	ocD	Oc at deceleration	Output current exceeds 2.4 times rated current during deceleration.	
03	ocn	Oc at normal SPD	Output current exceeds 2.4 times rated current during constant speed.	

13 SYSTEM ALARMS AND FAULTS

04	GFF	Ground Fault	Ground fault occurs when (one of) the output terminal(s) is grounded, and short-circuit current is greater than Pr. 06-60 setting, and the detection time is longer than Pr. 06-61.	Note: the short circuit protection is provided for the AC motor drive protection, and not to protect the user.
05	occ	Short Circuit	Short circuit detected between upper bridge and lower bridge of the IGBT module.	<ul style="list-style-type: none"> • Replace VFD.
07	ovA	Ov at acceleration	DC buss over-voltage during acceleration.	<ul style="list-style-type: none"> • Incoming power including voltage, phase and grounding exceeds 15 Ohms. Voltage spikes during certain times of day may cause this fault. Requires licensed electrician. • Deceleration time for the pump motor set to long. Decrease deceleration time.
08	ovd	Ov at deceleration	DC buss over-voltage during deceleration.	<ul style="list-style-type: none"> • Incoming power including voltage, phase and grounding exceeds 15 Ohms. Voltage spikes during certain times of day may cause this fault. Requires licensed electrician. • Deceleration time for the pump motor set to short. Increase deceleration time.
09	ovn	Ov at normal SPD	DC buss over-voltage during constant speed.	<ul style="list-style-type: none"> • Incoming power including voltage, phase and grounding exceeds 15 Ohms. Voltage spikes during certain times of day may cause this fault. Requires licensed electrician. • Pump motor parameters require adjustment. Adjust as necessary.
10	ovS	Ovat stop	DC buss over-voltage at stop.	<ul style="list-style-type: none"> • Incoming power including voltage, phase and grounding exceeds 15 Ohms. Voltage spikes during certain times of day may cause this fault. Requires licensed electrician. • Install AC line reactor.

14 TROUBLESHOOTING

General

This section is intended to give basic guidance when troubleshooting the Compact Low Profile Rapid Ship (CLPRS) pump station. It is not intended to be a comprehensive list of all possible problems or solutions.

Before beginning troubleshooting, read and follow the information in **2 Safety Information** section of this manual.

All electrical work or repairs must be made by a licensed electrician.

Always follow the National Electric Code (NEC), the National Fire Protection Association (NFPA) code and all local and state electrical and safety codes when performing repairs or working on the pump station.

Should you have any questions regarding troubleshooting for this pump station, contact Rain Bird Global Service Plan (GSP) support. See **1 Introduction** for contact information. Note the CLPRS Model and the Job Number found on the Job Information label inside the pump station enclosure on the left side (see Figure 6-3), and have this information ready when calling for support.

Checking Pump Station Input / Output, Statistics And Alarms

For purposes of troubleshooting, it may be necessary to check various information accessed from the System Status screen.

To check pump station Input / Output, see Pump Station Input / Output (I / O) in **10 Operator Interface** section.

To check pump station Statistics, see Station Statistics (Stats) in **10 Operator Interface** section.

To check pump station Alarms, see System And Variable Frequency Drive Alarms and Variable Frequency Drive Alarm History in **13 System Alarms And Faults** section.



Attempting to repair or work on the pump station when high voltage electricity is present in the pump station enclosure will result in death or serious injury. Always make sure the Fused Electrical Disconnect lever is in the OFF position, and that proper Lockout / Tagout procedures are followed before beginning repair or work inside the pump station enclosure.



Working inside or replacing fuses in the Fused Electrical Disconnect with electrically energized input leads will result in death or serious injury. Always make sure the service breaker or disconnect ahead of the pump station is OPEN, and that proper Lockout / Tagout procedures are followed before beginning work inside the Fused Electrical Disconnect.



Replacing a fuse in the Fused Electrical Disconnect with a fuse of a different amperage or type than the fuse being replaced will result in death or serious injury. Always replace a fuse in the Fused Electrical Disconnect with a fuse of the same amperage and type.

No.	Problem	Possible Cause	Possible Solution
1	The pump will not run when the AOM Switch is set to MANUAL.	The VFD has no power.	The Operator Interface should be lit and respond to inputs. If not, see Problem No. 3.
		Red Pump Station Alarm Light is illuminated.	If illuminated see Problem No. 5.
2	The pump will not run when the AOM Switch is set to AUTO.	The VFD has no power.	The Operator Interface should be lit and respond to inputs. If not, see Problem No. 3.

14 TROUBLESHOOTING

		Red Pump Station Alarm Light is illuminated.	If illuminated see Problem No. 5.
		Pump Start Relay is not receiving a signal from the external input.	<ul style="list-style-type: none"> Verify that the irrigation controller is properly connected to the Pump Start Relay. See Connecting An Irrigation Controller in 7 Connecting An External Input section. Verify that the start / wake parameters are set correctly. See Start / Wake Configuration in 12 Initial Start-Up Guide section.
		Flow Switch is not providing a start input.	<ul style="list-style-type: none"> Verify that the Flow Switch is properly connected to the VFD. Consult Rain Bird GSP support for procedure to verify proper connection of Flow Switch. Verify Flow Switch parameters. See Appendix D – Default Parameters. Verify that the water demand is high enough to trigger Flow Switch input to the VFD.
3	The VFD does not have power.	Fused Electrical Disconnect is OFF.	Determine the reason for the Fused Electrical Disconnect to be OFF, and correct. Be mindful of Lockout / Tagout procedures. Move the handle on the Fused Electrical Disconnect to the ON position.
		No electrical power to Fused Electrical Disconnect.	<ul style="list-style-type: none"> The service breaker or disconnect ahead of the pump station is OPEN. Be mindful of Lockout / Tagout procedures. CLOSE the service breaker or disconnect ahead of the pump station. Power outage. Consult utility company.
		One or more fuses blown in Fused Electrical Disconnect.	<ol style="list-style-type: none"> Verify that the service breaker or disconnect ahead of the pump station is OPEN. Use proper Lockout / Tagout procedures. Verify that the Fused Electrical Disconnect on the pump station is OFF by moving the handle on the Fused Electrical Disconnect to the OFF position. Use proper Lockout / Tagout procedures. Open the Fused Electrical Disconnect box. Remove fuses and check that their resistance with an Ohmmeter is 0. Fuses with infinite resistance are blown fuses. Replace any blown fuse with a fuse of the same amperage and type. Close the Fused Electrical Disconnect box.

14 TROUBLESHOOTING

			<ol style="list-style-type: none"> 7. Correct any overloads. 8. CLOSE the service breaker or disconnect ahead of the pump station. 9. Move the handle on the Fused Electrical Disconnect to the ON position. 10. If VFD still has no power, consult Rain Bird GSP support.
4	Pump is not achieving pressure when the AOM Switch is set to AUTO and Operator Interface shows the pump is running at 60 Hz.	Too many irrigation zones are on at the same time.	Adjust the irrigation programming so that pump flow demand remains within the Pump Flow Curve label.
		Stuck or leaking valve in the irrigation field.	Repair stuck or leaking valve.
		Not enough water supply to the pump.	<ul style="list-style-type: none"> • Verify that the primary valve ahead of the Flanged Intake Connection is open. • For Suction Lift applications, if pump pressure is 0 PSI at 60 Hz, pump needs to be primed. Follow procedure in 8 Priming The Pump – Suction Lift Applications section.
		The pump motor is not rotating the correct direction.	<p>Viewing from the pump motor fan end, the pump motor / fan must be rotating clockwise. If it is not, the L1 and L2 power leads are not connected to the correct terminals.</p> <ol style="list-style-type: none"> 1. Turn AOM Switch to OFF. 2. Move the handle on the Fused Electrical Disconnect to the OFF position. Use proper Lockout / Tagout procedures. 3. Verify that the service breaker or disconnect ahead of the pump station is OPEN. Use proper Lockout / Tagout procedures. 4. Open the Fused Electrical Disconnect box. 5. Swap the power leads between L1 and L2. <ol style="list-style-type: none"> a. Move the power lead from L1 to L2. b. Move the power lead from L2 to L1. 6. Close the Fused Electrical Disconnect box. 7. CLOSE the service breaker or disconnect ahead of the pump station. 8. Move the handle on the Fused Electrical Disconnect to the ON position. 9. Turn AOM Switch to Auto.
5	The red Pump Station Alarm Light is illuminated.	Note the alarm code on the Operator Interface to determine possible cause.	See System And Variable Frequency Drive Alarms in 13 System Alarms and Faults section for Alarm and Possible Causes. Correct the problem and reset the alarm. If the alarm persists, consult Rain Bird GSP support.

14 TROUBLESHOOTING

6	Pump continues to run after irrigation has ended.	Stuck or leaking valve in the irrigation field.	Repair stuck or leaking valve.
		Parameters for Sleep Configuration not properly set.	Check and set the parameters for Sleep Configuration. See Sleep Configuration in 12 Initial Start-Up Guide section.
		Flow Switch needs to be recalibrated.	See Calibrating The Flow Switch in this section.
7	Pump cycles on and off continuously while irrigating.	Pump flow demand for the irrigation zone is below the minimum pump flow as shown on the Pump Flow Curve label.	The pump flow demand in each irrigation zone must be greater than the Minimum Continuous Stable Flow (MCSF) rate for your model pump station. See Table 14-1 in Minimum Continuous Stable Flow Rate in this section.
		Flow Switch needs to be recalibrated.	See Calibrating The Flow Switch in this section.
8	Pump does not rotate freely.	Pump station remained in warehouse too long and pump motor bearings need greasing.	See Pump Motor Bearings in 12 Initial Start-Up Guide section, and Pump Motor Bearing Greasing in 15 Maintenance section.
9	One of the input phases to the VFD is unbalanced or open.	One or more fuses blown in Fused Electrical Disconnect.	See Problem No. 3, "One or more fuses blown in Fused Electrical Disconnect".
		Screw(s) securing wiring to the VFD are loose.	<ol style="list-style-type: none"> 1. Turn AOM Switch to OFF. 2. Move the handle on the Fused Electrical Disconnect to the OFF position. Use proper Lockout / Tagout procedures. 3. Verify that the service breaker or disconnect ahead of the pump station is OPEN. Use proper Lockout / Tagout procedures. 4. Open the Fused Electrical Disconnect box, and the VFD enclosure. 5. Check the wiring between the Fused Electrical Disconnect and the VFD. 6. Ensure that all wiring connections are tight both at the Fused Electrical Disconnect and the VFD. 7. Close the Fused Electrical Disconnect box and the VFD enclosure. 8. CLOSE the service breaker or disconnect ahead of the pump station. 9. Move the handle on the Fused Electrical Disconnect to the ON position. 10. Turn AOM Switch to Auto.
10	One of the output phases to the pump motor is open.	Check wiring between VFD and pump motor.	<ol style="list-style-type: none"> 1. Turn AOM Switch to OFF. 2. Move the handle on the Fused Electrical Disconnect to the OFF position. Use proper Lockout / Tagout procedures. 3. Open the VFD enclosure, and the pump motor junction box. 4. Check the wiring between the VFD and the pump motor.

14 TROUBLESHOOTING

			<ol style="list-style-type: none">5. Ensure that all wiring connections are tight both at the VFD and the pump motor. Re-install wire nuts or split bolts in the pump motor junction box as necessary.6. Close the VFD enclosure, and the pump motor junction box.7. Move the handle on the Fused Electrical Disconnect to the ON position.8. Turn AOM Switch to Auto.9. If problem persists, disconnect pump motor wires from VFD. Perform a motor insulation test with a 500 VDC meg-ohm meter and phase integrity test. Repair or replace pump motor as necessary.
--	--	--	---

15 MAINTENANCE

General

Rain Bird can provide preventive maintenance and winterization services through a Rain Bird Authorized Service Provider. Extended warranty options are also available. Contact the Rain Bird GSP team at 1-866-477-9778 for information.

Should you have any questions or issues regarding maintenance, contact Rain Bird Global Service Plan (GSP) support. See **1 Introduction** for contact information. Note the CLPRS Model and the Job Number found on the Job Information label inside the pump station enclosure on the left side (see Figure 6-3), and have this information ready when calling for support.

Pump Motor Bearing Greasing

Rain Bird uses several different pumps in the Compact Low Profile Rapid Ship (CLPRS) pump station series. Some pump motors are equipped with “lubed for life” motor bearings, while others require that the motor bearings be greased periodically.

“Lubed for life” pump motors are clearly marked “Do Not Lubricate” on the motor nameplate.

Pump motors that require greasing will be equipped with grease fittings at the motor bearings. Pump motors with grease fittings must be greased once every calendar year.

NOTICE

For those pump stations with pump motors having grease fittings, when installing a new pump station, check the testing date on the Job Information label on the left side of the pump station enclosure. If 6 months or longer has elapsed since the pump station “Tested By” date, the pump motor bearings may need to be greased before starting the pump. Refer to the pump / motor manufacturers manual for lubrication recommendations.

The manufacturer of pump motors with grease fittings requires that the motor bearings be lubricated periodically. Refer to the pump / motor manufacture’s manual for lubrication schedule and type of grease required.

Before beginning greasing the pump motor, read and follow the information in **2 Safety Information** section of this manual.

Read and understand all instructions, hazard warnings and relevant appendices before beginning pump motor bearing greasing.

To grease pump motors with grease fittings:

1. Set the Auto-Off-Manual (AOM) Switch (E, Figure 4-1) in the OFF position. See Figure 6-2.



Working with electrically energized components in the pump station enclosure will result in death or serious injury. Always make sure the Fused Electrical Disconnect on the pump station is OFF, and that proper Lockout / Tagout procedures are followed before beginning greasing the pump motor.

2. Set the Fused Electrical Disconnect (P, Figure 4-2) on the pump station to OFF. The handle must be in the down position. See Figure 6-1.
3. Check for debris that could block pump motor ventilation. Clean as necessary.
4. Wipe grease away from the grease fittings with a clean cloth. See Figures 15-1 and 15-2 for location of grease fittings.

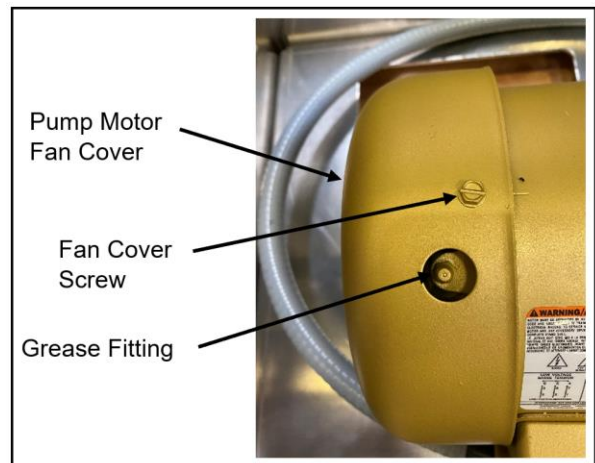

Figure 15-1. Location Of Rear Grease Fitting.

15 MAINTENANCE

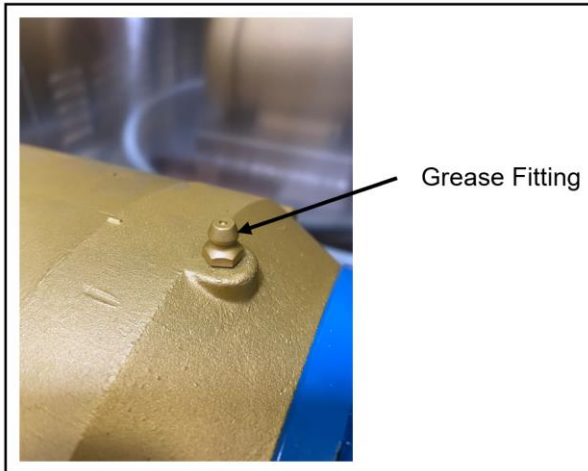

Figure 15-2. Location Of Front Grease Fitting.

5. Remove the grease outlet plugs located on the bottom of the motor opposite the grease fittings.
6. Using the appropriate grease gun, pump grease into each of the pump motor's grease fittings. See pump motor manufacturer's User Manual for additional information on greasing.
7. Wipe up any excess grease from under the pump motor that was purged from the grease outlet plug holes during greasing. Clean any grease from the grease outlet plug holes and re-install the plugs.
8. Apply electrical power to the pump station by setting the Fused Electrical Disconnect on the pump station to ON. The handle must be in the up position. See Figure 12-3.

Winterization

Pump stations installed in areas where the temperature can drop below 32° F (0° C) require winterization to prevent freeze damage and to ensure a smooth start-up in spring.

Before beginning winterizing the pump station, read and follow the **2 Safety Information** section of this manual.

Read and understand all instructions, hazard warnings and relevant appendices before beginning winterization of the pump station.

To winterize the pump station:

1. Set the Auto-Off-Manual (AOM) Switch (H, Figure 1) in the OFF position. See Figure 6-2.

DANGER

Working with electrically energized components in the pump station enclosure will result in death or serious injury. Always make sure the Fused Electrical Disconnect on the pump station is OFF, and that proper Lockout / Tagout procedures are followed before beginning winterization of the pump station.

2. Set the Fused Electrical Disconnect (P, Figure 4-2) on the pump station to OFF. The handle must be in the down position. See Figure 6-1.
3. Install a padlock on the Fused Electrical Disconnect locking it in the OFF position.
4. Verify that the service breaker or disconnect ahead of the pump station is OPEN. Use proper Lockout / Tagout procedures.
5. Ensure that the master valve directly after the pump station discharge is closed.
6. Ensure that the Discharge Ball Valve (C, Figure 4-1) is open by placing the handle controlling the valve butterfly parallel to the discharge piping. See Figure 8-2.
7. Drain the pump by removing the lowest Pump Drain Port plug on the pump volute (at 6 o'clock position).

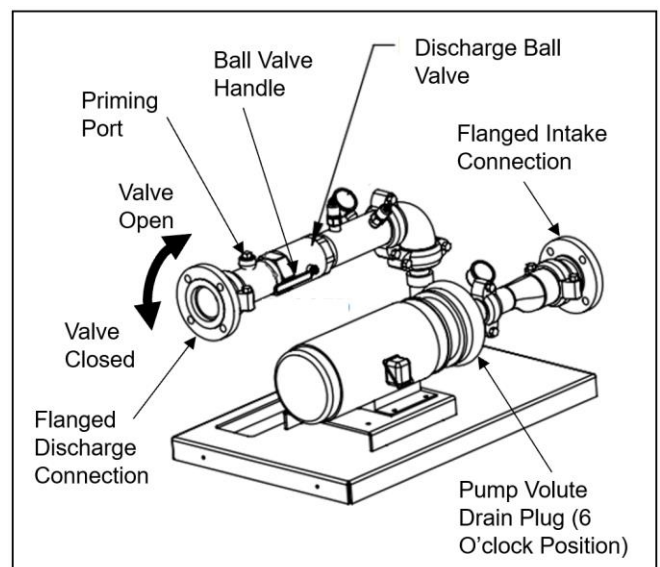

Figure 15-3. Pump Drain And Priming Ports.

8. Drain the water intake system completely.
 - a. For Pressure Boost and Flooded Suction applications (see **Appendix A – Pump Intake Applications**), the source water

15 MAINTENANCE

- must be shut off and piping to the pump intake drained.
- b. For Suction Lift applications (see **Appendix A – Pump Intake Applications**), remove foot valve and suction screen and store them in a dry place. Drain water from the suction line and remove the suction line from standing water as necessary.
9. Open the $\frac{3}{4}$ NPT Priming Port (B, Figure 4-1). Compressed air may be used in this port to blow remaining moisture from the system.
 10. Re-install the $\frac{3}{4}$ NPT plug in the Priming Port and the plug for the lowest Pump Drain Port following the standard procedure for assembling tapered pipe threads.
 11. Remove the Pressure Transducer and store the Pressure Transducer where it will not be subject to freezing.
 - a. Remove the Pressure Transducer cable by unscrewing the M12 connector.
 - b. Remove the Pressure Transducer by unscrewing it from the discharge piping.
 - c. Install a $\frac{1}{4}$ NPT plug in the Pressure Transducer hole to prevent debris from entering the water system.
 12. Secure the pump station enclosure lid with a padlock or zip-tie to prevent damage in high winds.

To place the pump station back in service:

1. Remove the padlock or zip-tie from the pump station enclosure lid.
2. Verify that the Discharge Isolation Valve is closed. See Figure 8-2 in **8 Priming The Pump – Suction Lift Applications** section.
3. Re-install the Pressure Transducer.
 - a. Remove the $\frac{1}{4}$ NPT plug from the Pressure Transducer hole.
 - b. Re-install the Pressure Transducer following the standard procedure for assembling tapered pipe threads.
 - c. Re-install the Pressure Transducer cable by screwing the M12 connector onto the Pressure Transducer.
4. Verify that the $\frac{3}{4}$ NPT plug in the Priming Port on the intake pipe, and the lowest Pump Drain Port plug on the pump volute (at 6 o'clock position) are installed and tight. See Figure 15-3.
5. Grease the pump motor bearings. See Pump Motor Bearing Greasing in this section.

6. Open the water intake system to the pump.
 - a. For Pressure Boost and Flooded Suction applications, the source water must be turned on.
 - b. For Suction Lift applications, re-install foot valves and suction screens and suction lines as necessary.
 - c. For Suction Lift applications, prime the pump per **8 Priming The Pump – Suction Lift Applications**.
7. Open the Discharge Isolation Valve by placing the handle controlling the valve butterfly parallel to the discharge piping. See Figure 12-8.
8. Ensure that the master valve directly after the pump station discharge is open.
9. Verify that the service breaker or disconnect ahead of the pump station is CLOSED.
10. Remove the padlock from the Fused Electrical Disconnect.
11. Apply electrical power to the pump station by setting the Fused Electrical Disconnect on the pump station to ON. The handle must be in the up position. See Figure 12-3.
12. Set the pump station Real-Time Clock (RTC). Follow the instructions in Setting The System Clock in **12 Initial Start-Up** section.

NOTICE

Damage to the pump station caused by improper or incomplete winterization is not covered under the Rain Bird Customer Satisfaction Policy. Always follow the winterization procedure to prevent damage to the pump station.

APPENDIX A – PUMP INTAKE APPLICATIONS

Intake water may be supplied to the pump station by any of three different applications.

Pressure Boost

In Pressure Boost applications, the pump is fed water from a pressurized line such as a city water main. As the pump produces the desired flow, it “boosts” the pressure to the irrigation system. See Figure A-1.

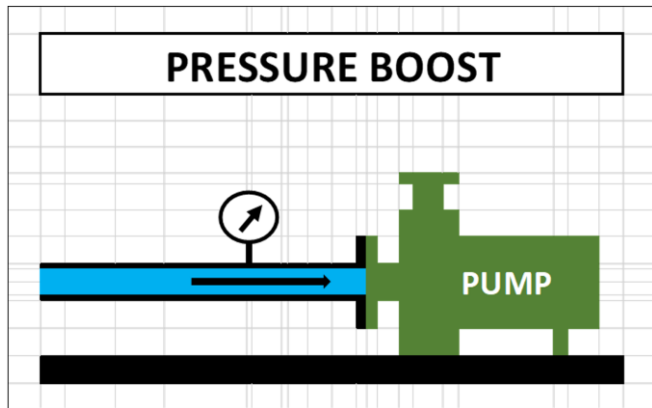

Figure A-1. Pressure Boost Application.

Suction Lift

In Suction Lift applications the pump draws water up from a tank or natural source where the water level is below the pump station. This requires special considerations such as a foot valve and/or a suction screen to ensure the pump remains primed and is capable of operating. See Figure A-2.

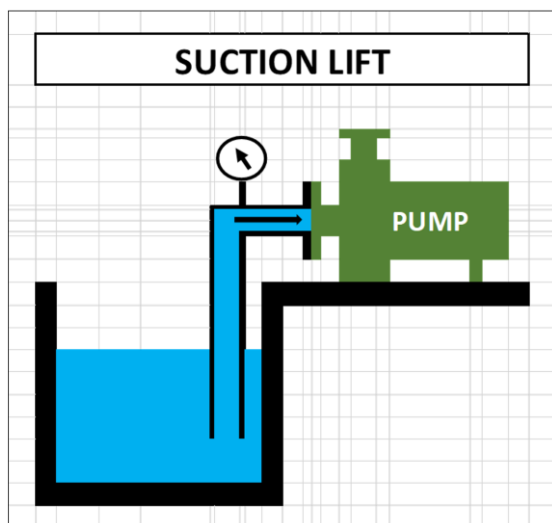

Figure A-2. Suction Lift Application.

Flooded Suction

In Flooded Suction applications the pump is fed from a vented tank with a water level above the pump station. See Figure A-3.

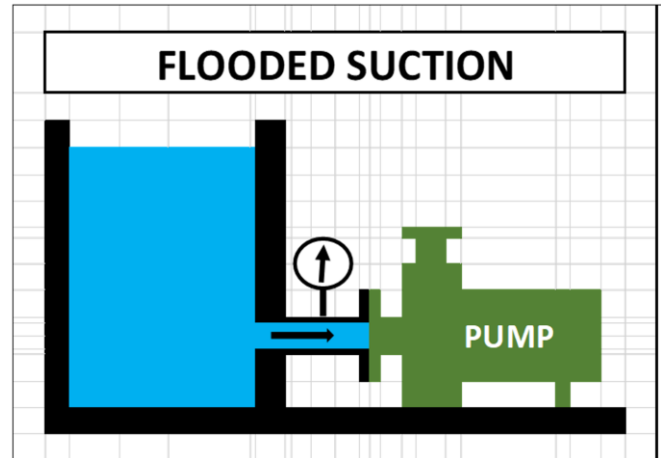

Figure A-3. Flooded Suction Application.

APPENDIX B – SUCTION LINE AND FOOT VALVE GUIDE

Improperly installed suction lines and / or foot valves can be troublesome when pump stations are used in Suction Lift applications. The following guidelines are intended to assist with the successful installation and trouble-free operation of the pump station.

Suction Line Guidelines

1. Suction lines should be kept as short as possible to keep the pressure drop at the intake low. Locate the pump station as close to the water source as feasible.
2. The suction line pipe diameter must be equal to or greater than the Grooved Intake Connection on the pump station. The water velocity through the suction line should be 7-8 feet per second or less.
3. The suction line must not allow pockets of air to become trapped in the piping.
 - a. The intake of the suction line must be kept completely submerged. The intake must be deep enough in the water source to prevent air vortices from reaching the inlet to the suction line.
 - b. The entire length of the suction line must slope gently up toward the Grooved Intake Connection. Do not allow low points that can trap pockets of air.
 - c. If it is necessary to reduce the pipe diameter of the suction line pipe, the pipe diameter must progress from larger to smaller as the suction line approaches the Grooved Intake Connection. Use an eccentric reducer when changing pipe size.
 - d. All pipe joints must be leak free to prevent air entering the suction line.
4. The intake of the suction line must not allow entrained solids or debris from entering suction line.
 - a. Keep the intake of the suction line high enough off the bottom of the water source to prevent ingesting mud, silt or other debris.
 - b. If the water source is dirty and prone to fouling the seat of the foot valve, a strainer must be installed. The strainer must be 3 times the diameter of the suction pipe, and have a mesh with holes no larger than ¼ inch (6 mm).

5. Avoid elbows or bends in the suction line. If an elbow in the suction line is necessary, provide a straight pipe with a minimum length of 10 pipe diameters between the elbow and the Grooved Intake Connection.
6. Do not allow excess strain on the Grooved Intake Connection.
 - a. Properly support the suction line to the Grooved Intake Connection. Do not allow the weight of the suction line to induce a torque on the pump casing. This can lead to reduced pump performance and shorter pump life.
 - b. Install appropriate thrust blocking on any pipe bends to ensure hydraulic forces do not place strain on the suction line or pump casing.

Foot Valve Guidelines

1. Size the foot valve and / or strainer per the manufacturer's recommendations for maximum flow in the irrigation system.
 - a. Undersized foot valves will cause suction line problems. The pump will work harder to deliver water with an undersized foot valve. They are also more susceptible to water hammer damage.
 - b. Oversized foot valves may require too much force to open them, and cause the pump to work harder to deliver water.
2. Select the appropriate foot valve for the orientation in which it will be installed.
 - a. Foot valves are designed for a specific orientation. Vertical foot valves must be installed on a vertical or near-vertical suction line. Horizontal foot valves must be installed on a horizontal or near-horizontal suction line.
 - b. Foot valves that are designed to be used at 45° must be used at angles below horizontal, but not at angles greater than 45° below the horizontal.
3. Check the foot valve seat to make sure the flapper seals against the seat. Remove any foreign material from the seat.
4. When placing the pump station back into service after winterization, inspect the foot valve seat for damage or debris. If the pump station does not hold prime, the most common problems are unseated foot valves and leaks in the suction line.

APPENDIX C – POWER GROUNDING SYSTEMS

The Delta Variable Frequency Drive (VFD) contains a Radio Frequency Interference (RFI) jumper that, when installed on a symmetric (balanced) 3-phase power system, will protect the VFD from transient voltage spikes and main line surges, as well as high frequency noise. This jumper must be removed on asymmetric grounding power systems, including single phase

systems to prevent grounding through the filter capacitors and causing damage to the VFD.

Table C-1 shows symmetric and asymmetric grounding power systems. Determine which power system is used for powering the pump station before deciding whether the RFI jumper needs to be removed.

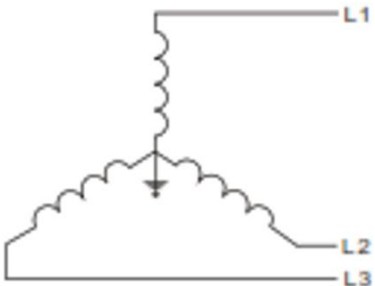
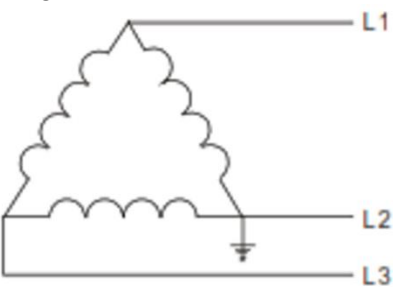
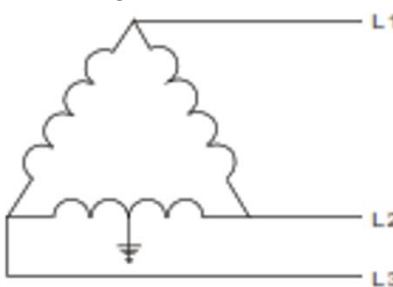
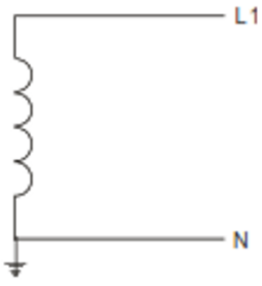
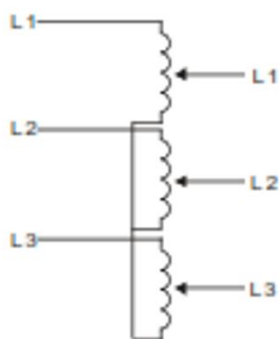
SYMMETRIC POWER GROUNDING SYSTEM. The RFI Jumper Need Not Be Removed.	
Symmetric Wye or "Y" 3-phase grounding power systems do not need to have the RFI jumper removed. This will maintain the effect of the built-in ElectroMagnetic Compatibility (EMC) filter and surge suppressor.	
	
ASYMMETRIC POWER GROUNDING SYSTEMS. The RFI Jumper Will Need To Be Removed.	
Asymmetric grounding at the corner of a Delta or Δ 3-phase configuration.	Asymmetric grounding at the midpoint of a Delta or Δ 3-phase configuration.
	
Asymmetric grounding at the end of a single-phase configuration.	No stable neutral grounding in a 3-phase autotransformer configuration.
	

Table C-1. Symmetric And Asymmetric Power Grounding Systems.