

ACLP Series – ACLP10LAC

Advanced Compact low profile 10HP VFD Pump Station

Up to 160 GPM at 64 PSI or up to 40 GPM at 79 PSI

(See Performance Curve)

Rain Bird's ACLP series pump stations are UL listed packaged pump stations designed for boost, suction lift or flooded suction applications. The ACLP station features a marine-grade aluminum enclosure, professional-grade centrifugal pump, and powder coated carbon steel piping for efficient performance and maximum corrosion resistance. The ACLP stations feature variable speed controls to smoothly, efficiently, and reliably produce constant pressure at varying flow rates within a large envelope of operation. See individual pump performance curves for details.

At-A-Glance Description

- **Variable Frequency Drive (VFD)**
- **Pump Start Relay** included (24VAC/DC with surge protection)
- **Flow Switch** included
- **Bladder Tank** included
- **Marine-Grade Aluminum Enclosure and deck with an exhaust fan**
- **Isolation Valves** for easy maintenance
- **Auto-Off-Manual Switch** provides the user full control and override capabilities
- **Available in single and three phase 208V, 220V, 230V, VAC and three phase 480V VAC configurations**
- **Multiple options for boost, flooded suction, and suction lift applications (see options list)**
- **External Fault / Alarm and Run lights**

Features

- **Plumbing Configurations**
 - Inlet and discharge piping on opposite sides of the enclosure (as shown)
 - Grooved ends for easy installation
 - ½" priming port
- **Mechanical Features**
 - Discharge and intake isolation valves
 - Liquid filled pressure gauges on intake and discharge piping
 - Rugged centrifugal pump
- **Enclosure / External Connections**
 - Marine-grade aluminum enclosure with exhaust fan
 - Marine-grade aluminum deck

- Powder-coated steel piping
- Fused main power external disconnect switch
- 100kA short circuit current rating

Pump Control

- **24V AC/DC pump start relay included for optional remote control Autonomous controls with wake on low pressure and retire on low flow**
- **Low flow rate is verified with a pressure test prior to retiring the pump to prevent frequent motor starts and extend equipment life**

Electrical Features

- **Power Requirement: Single or three phase 208V, 220V, 230V AC or three phase 480V AC**
- **TEFC Motor**
- **UL Listed QCZJ packaged pump system file E249335**
- **UL Listed NITW control panel file E251596**

Energy efficient Variable Frequency Drive (VFD) maintains constant pressure at varying flow demands

- **External NEMA 3R fused main power disconnect**
- **External Red light for VFD alarms**
- **External Green pump running light**
- **Stainless steel pressure transducer**

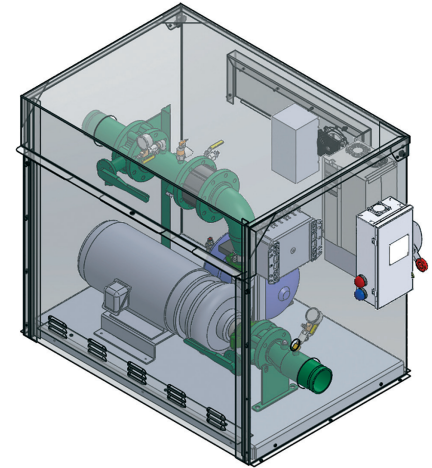

- **Loss of prime and pipe break alarms**
- **Dead head shut down**
- **Transducer loss shut down**

Options and Accessories

- **Rain Bird automatic suction scanning filter**
- **Surge Suppression Kit**
 - Single phase (208V, 220V, or 230V AC)
 - Three phase (208V, 220V, 230V or 480V AC)
- **Stainless steel piping to replace internal powder coated carbon steel piping**
- **Environmental package, includes space heater and enclosure insulation**
- **Passive intake strainer and foot valve assembly for suction lift applications**
- **Self-cleaning inlet strainer and foot valve assembly for improved suction lift performance**

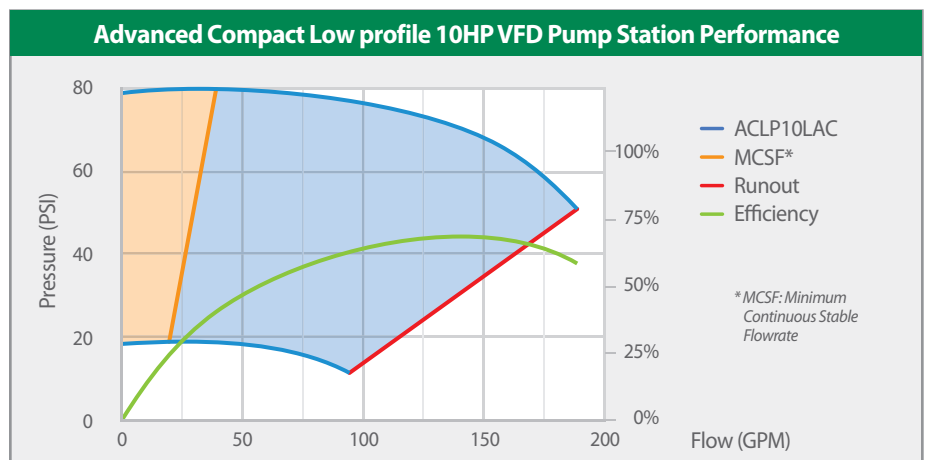

Details

REFER TO PERFORMANCE FLOW CHART OR PUMP CURVE TO DETERMINE YOUR OPERATING FLOW AND PRESSURE COMBINATION

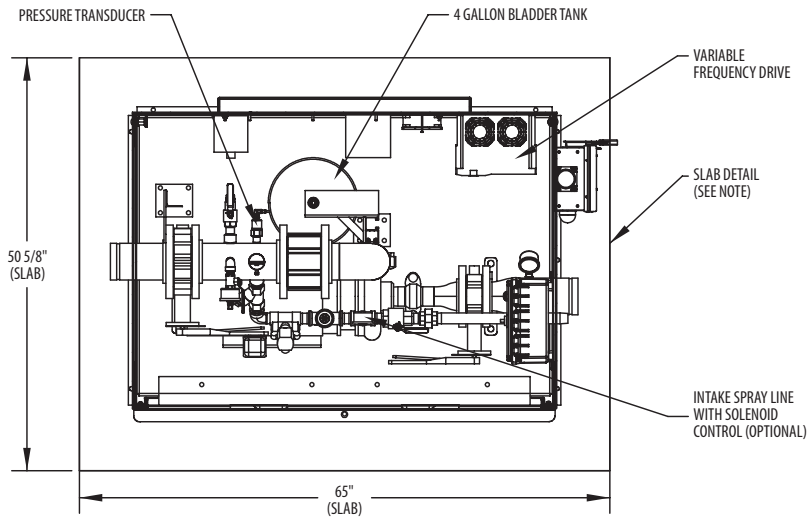

Plan View

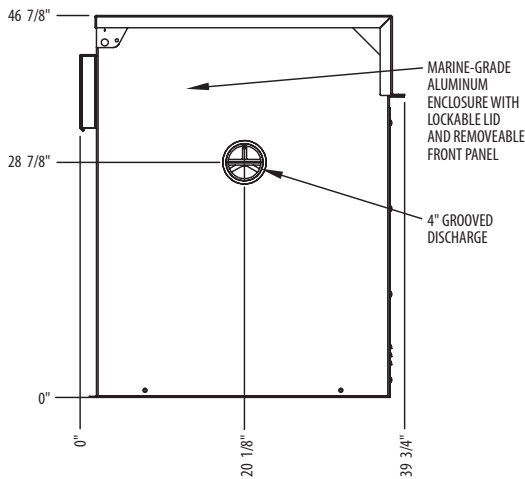
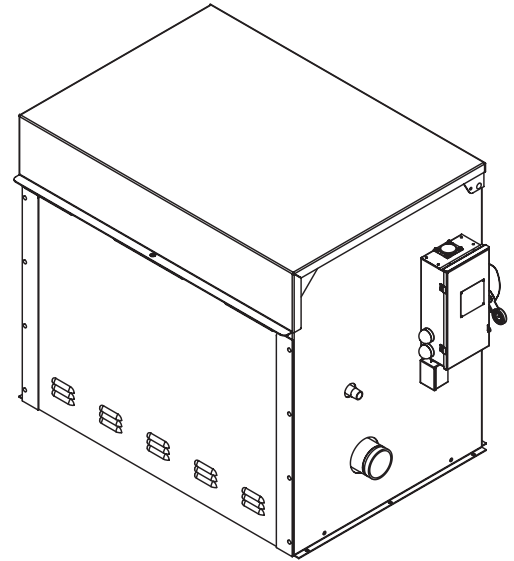

Side View

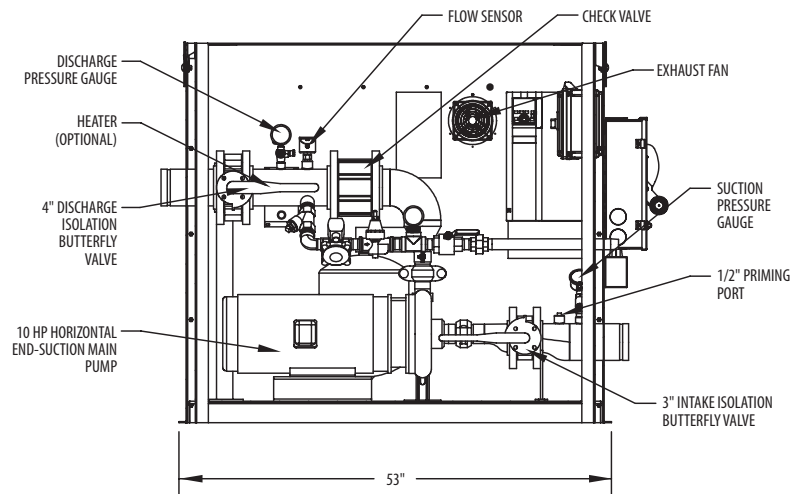

Profile View

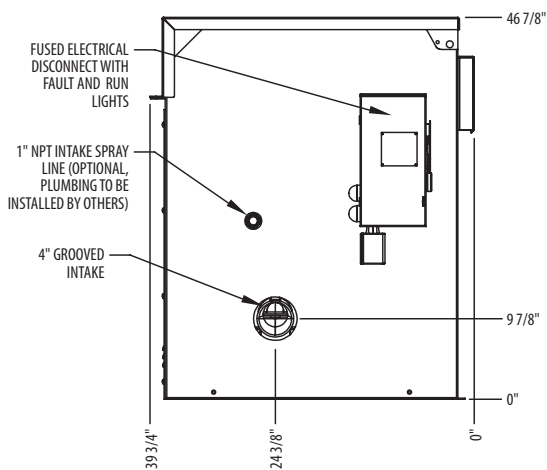

- NOTES:
1. SLAB DETAIL IS PROVIDED FOR ILLUSTRATION ONLY. THE ARCHITECT OR PROJECT ENGINEER SHOULD BE CONSULTED FOR CONSTRUCTION DETAIL.
 2. DIMENSIONS ARE FOR REFERENCE ONLY. EXTERNAL PLUMBING TO BE FIELD FIT.
 3. STATION WEIGHS ~ 250 LBS.

ACLP 10 L A C 4 - GL

Motor HP: 10

See selection guide for available 3HP, 5HP, 7.5HP, 10HP, 15HP and 20HP options.

Pump Curve: L

Curve available below. See selection guide for curves A - W.

Piping:

C: powder coated carbon steel piping.
S: optional stainless steel piping available.

Voltage

4: 1ø208VAC
5: 3ø208VAC
6: 1ø230VAC
7: 3ø230VAC
8: 3ø480VAC

Optional Filter:

GL: 3" 200GPM max flow Suction Scanner Filter

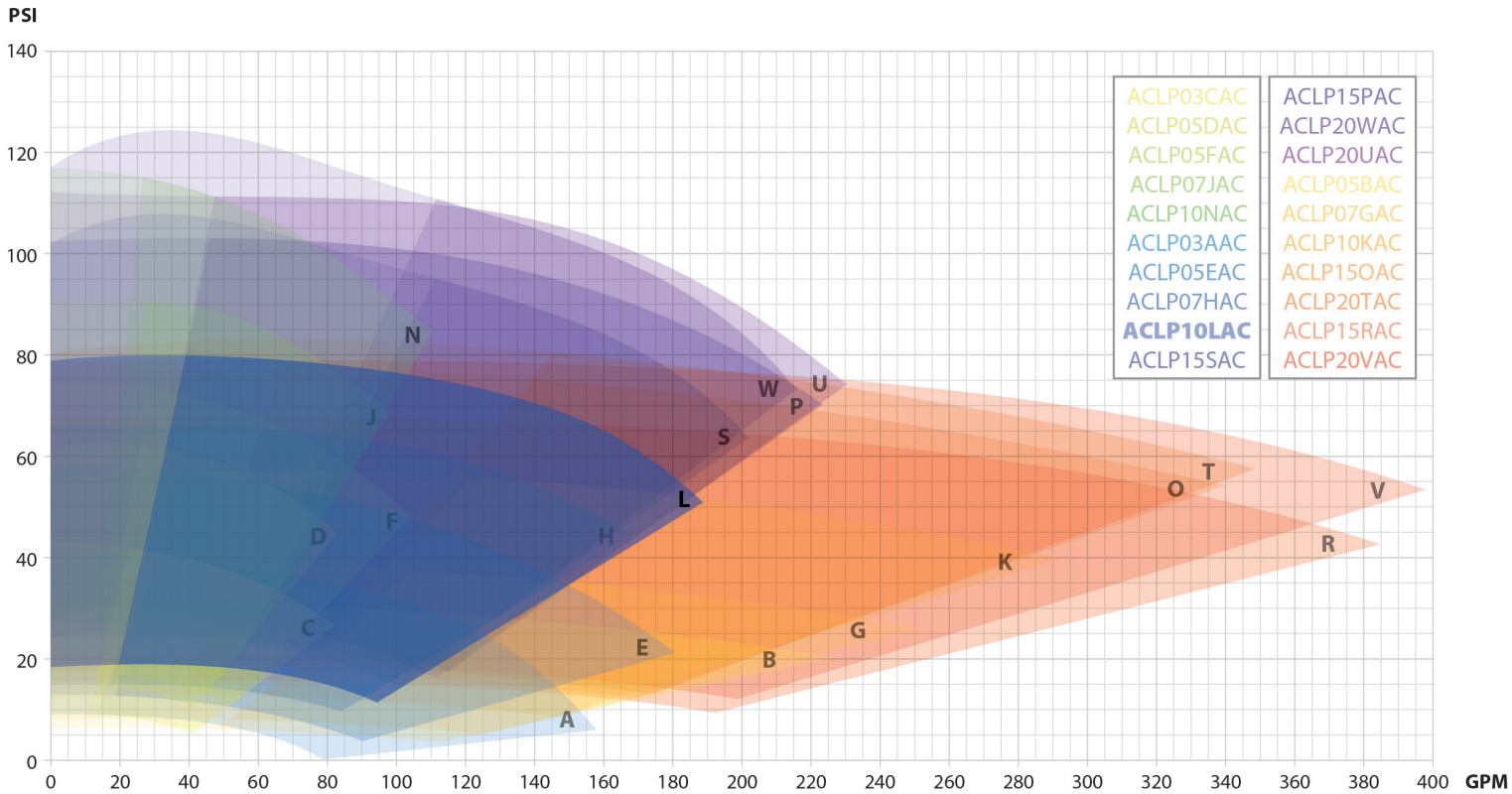

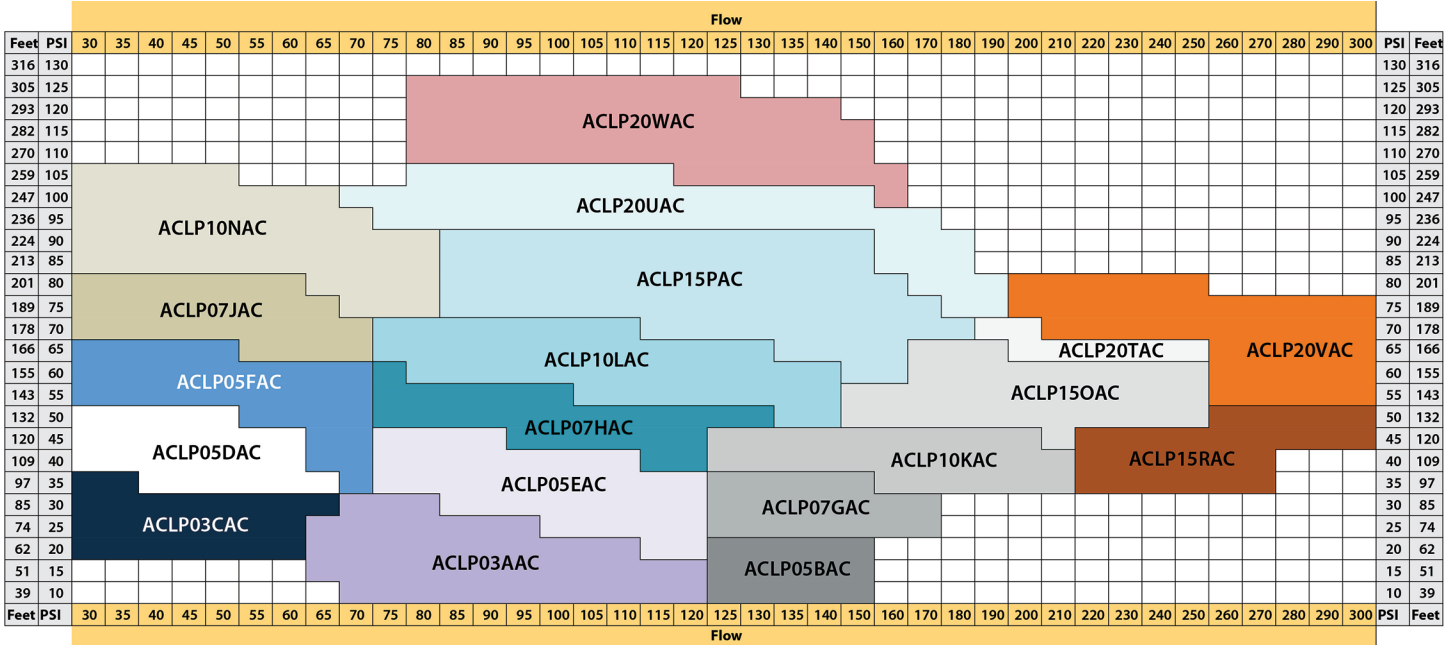

Rain Bird Corporation - Pumps Division
 6991 E. Southpoint Road
 Tucson, AZ 85756
 Applications Group: (520) 806-5620
 Fax: (520) 741-6191
 E-mail: pumps@rainbird.com

The Intelligent Use of Water™
www.rainbird.com